

---

# PRE-CHECK (PC) DESIGN CRITERIA FOR OPEN FABRIC SHADE STRUCTURES: 2022 CBC

---

**Disciplines:** All

**History:**

Revised 11/17/22 Under 2022 CBC

Issued 03/27/20 Under 2019 CBC

---

Division of the State Architect (DSA) documents referenced within this publication are available on the [DSA Forms](#) or [DSA Publications](#) webpages.

## PURPOSE

This Interpretation of Regulations (IR) clarifies requirements relating to pre-check (PC) submittals to promote uniform statewide criteria for code compliance in design and plan review of open fabric shade structures for projects under DSA jurisdiction. The PC Design Criteria documents were created by DSA as a means for the responsible engineer to demonstrate code compliance when developing and submitting construction documents for DSA review.

The provisions of this IR are intended to be a tool to identify and highlight the common and unique, critical and/or overlooked code requirements that must be considered and incorporated into the design, as applicable, to provide a complete and consistent set of construction documents accepted at all DSA regional offices. Other methods proposed by design professionals to solve a particular issue may be considered by DSA and reviewed for code and regulation compliance, subject to concurrence of DSA Codes and Standards Unit. For methods not specifically prescribed in the code, see California Building Code (CBC) Section 104.11.

Appendix A is provided below as a guide to assist design professionals and DSA plan reviewers when preparing and reviewing site-specific project applications that incorporate PC fabric shade structures designed in accordance with this IR.

## SCOPE

The provisions of this IR apply to 2022 PC plans for new open fabric shade structures submitted to DSA under the 2022 CBC. Open fabric shade structures are defined as exterior free-standing structures with open sides and a fabric canopy covering the top surface. They are used for various occupancies. Structural framing shall provide support for the canopy for all vertical and lateral loads.

As noted in *Bulletin (BU) 18-01: Applicability of Pre-Check (PC) Design Criteria for Non-PC Projects*, these provisions shall also be considered and incorporated in site-specific submittals for structures of the same project type, even if the submittal is not part of a PC application.

## BACKGROUND

The PC approval process is intended to streamline DSA plan review by providing a procedure for approving the design of commonly used structures prior to the submittal of plans to DSA for construction projects. The PC approval process allows designers to incorporate designs for structures that have already been “prechecked” by DSA into their plans for actual site-specific construction projects. The design criteria provided in this document are neither regulations nor law and are not appropriate for verbatim inclusion in project specifications. The design professional in responsible charge is responsible for specifying and detailing requirements for each project. Additional information regarding the design and site application of PC structures can be found in *Procedure (PR) 07-01: Pre-Check (PC) Approval* and *Policy (PL) 07-02: Over-the-Counter Review of Projects Using Pre-Check (PC) Approved Designs*.

---

**PRE-CHECK (PC) DESIGN CRITERIA FOR OPEN FABRIC SHADE STRUCTURES:  
2022 CBC****1. GENERAL****1.1 Pre-Check Submission Requirements**

See PR 07-01 for a detailed list of items that are required for all PC submittals. The documents required to be submitted for PC approval are listed on form *DSA 3: Project Submittal Checklist*. Site-specific information is not necessary as that information will be provided when a specific construction project is submitted for DSA review.

**1.2 Cover Sheet and General Notes**

**1.2.1** In accordance with PR 07-01 Section 2.4 the first sheet(s) of the PC drawings shall include a design information section that defines the basis of the PC design. Refer to PR 07-01 Appendices B and C, and the remainder of this IR for required content of the design information section.

**1.2.2** The following information, as a minimum, shall be included on the PC drawings for open fabric shade structures. This is not intended to be an all-inclusive list, and additional items may be required.

**1.2.2.1** Applied design loads. See Sections 3 and 4 below.

**1.2.2.2** Base reactions for each load case at points of support.

**1.2.2.3** Type of fabric, minimum specified fabric strength, maximum modulus of elasticity, and minimum seam strength (when applicable) for each part of structure.

**1.2.2.4** The maximum prestress force (P) and the maximum cable allowable strength ( $S_a$ ) per American Society of Civil Engineers Standard 19: Structural Applications of Steel Cables for Buildings (ASCE 19) Section 3.3.1 for each cable size in the PC.

**1.2.2.5** The direction of the warp and fill.

**1.2.2.6** Type and location of any mechanical connections.

**1.2.3** The PC construction documents shall include complete and comprehensive general notes and/or specifications as required for construction and inspection. It is common for PC construction documents to consist of drawings only without a book specification or project manual. Refer to PR 07-01 Appendix B, Footnote 6. In this case, the PC drawings shall include information that might otherwise be communicated in a project manual or book specification. For each primary material or group of materials, the following information shall be specified in the construction documents when applicable:

**1.2.3.1** Required material properties, including compliance with American Society for Testing and Materials (ASTM) specifications when applicable.

**1.2.3.2** Proprietary products name, manufacturer, and evaluation report number. Refer to Section 1.12 below.

**1.2.3.3** Quality control performed by the supplier.

**1.2.3.4** Standards for the execution of the work, including associated tolerances. References to recognized standards are acceptable.

**1.2.3.5** Required qualifications of personnel performing the work for each applicable trade.

**1.2.3.6** Product and material finishes where required for weather protection or safety.

**1.2.3.7** Quality assurance tests and frequency requirements (including citation of ASTM standards when applicable) not covered by Section 1.3 below.

---

## PRE-CHECK (PC) DESIGN CRITERIA FOR OPEN FABRIC SHADE STRUCTURES: 2022 CBC

### 1.3 Structural Tests and Special Inspections

Provide example form(s) *DSA 103: Listing of Structural Tests and Special Inspections* on the drawings. See PR 07-01 Section 2.5 for additional information.

**1.3.1** Example form DSA 103 will be used as a guide to develop a site-specific form DSA 103 for the site-specific project. Example form(s) on the PC drawings will be crossed out when the site-specific form DSA 103 is provided with the site-specific application.

**1.3.2** The example form DSA 103 will include both in-plant and on-site testing and inspection requirements. Manufacturers shall be involved in the coordination of in-plant testing and inspection with the project inspector, Laboratory of Record (LOR), and owner of the site-specific project application using the PC design prior to commencing fabrication.

**1.3.3** Only the site-specific form DSA 103 can identify exemptions from the required structural tests and special inspections; therefore, the Appendix of the example form(s) DSA 103 shall not be included on the PC drawings. Applicability of exemptions may be considered during plan review for site-specific applications, shall be justified by the project design professional, and is subject to DSA review and approval. Refer to Appendix A below for additional information.

### 1.4 Options and Variations

The PC drawings shall provide checkboxes of options and variations if there is more than one configuration or design criteria. See PR 07-01 Section 3 for more details, including the maximum number of options permitted.

### 1.5 Design Parameters

The PC drawings shall provide on the cover sheet (and subsequent sheets as necessary) design information as defined in PR 07-01 Section 2.4 and Appendix B. If the PC includes design variations for multiple tiers or levels of the same design parameter(s), all or part of the design information should be presented in a checklist format and provide general direction to future users (design professionals and plan reviewers) for the application of the PC to site-specific projects. Additionally, refer to and coordinate with PL 07-02 Section 3, which summarizes common site-specific parameters to be verified at Over-the-Counter (OTC) plan reviews.

### 1.6 Risk Category and Occupant Load

The PC drawings shall indicate the maximum Risk Category (RC) the structure is designed for in the design information section of the cover sheet.

In addition, the design information section shall include a note requiring the intended *Use and Occupancy* be specified on the site-specific application drawings, so the DSA reviewer can verify the RC of the PC structure as it applies to the site in accordance with CBC Section 1604A.5. For this purpose, the PC drawings shall include a Code Analysis table with columns for the definition of Use and Occupancy classification per CBC Chapter 3, Occupant Load Factor (OLF) per CBC Table 1004.5, and total occupant load, to be completed by the design professional at time of the site-specific application. The site-specific RC will correspondingly be determined from the site-specific occupant load in accordance with CBC Table 1604A.5. Refer to Appendix A below for additional information.

### 1.7 Flood Zone

The PC design shall comply with CBC Section 1612A and *PR 14-01: Flood Design and Project Submittal Requirements*.

---

**PRE-CHECK (PC) DESIGN CRITERIA FOR OPEN FABRIC SHADE STRUCTURES:  
2022 CBC**

**1.7.1** The design information section shall include a note stating that when a site-specific project is located in a flood zone other than Zone X, a letter from a geotechnical engineer (bearing his/her stamp and signature) is required to validate the applicability of the allowable soil values listed on the PC drawings.

This note may include an exemption for the validation letter for projects located in Zone D (undefined) if the applicant provides either (1) evidence from the local jurisdiction or a qualified design professional confirming the site is not in a flood hazard zone or (2) a geotechnical report written for improvements on the same campus and in accordance with the current CBC acknowledges the flood hazard but confirms it does not result in reduction of soil capacity values.

**1.7.2** The location of electrical elements shall conform to the American Society of Civil Engineers Standard 24: Flood Resistant Design and Construction (ASCE 24) Section 7.2.

### **1.8 Geohazard Reports**

It is recommended the design information section state that geohazard reports are not required for open fabric shade structures 1,600 square feet (SF) or less complying with the requirements of *IR A-4: Geohazard Report Requirements*, Section 3.1.1.1. Open fabric shade structures greater than 1,600 SF up to a maximum of 4,000 SF and complying with the requirements noted in IR A-4 Section 3.1.1.1 do not require a geohazard report provided a geotechnical report indicates that no liquefaction potential exists.

### **1.9 Weather Protection**

The PC drawings shall specify the type of weather protection selected for all weather-exposed steel members (i.e., structural steel and cold-formed steel) in accordance with CBC Section 2203A.1.

**1.9.1** Structural steel shall comply with one of the following:

**1.9.1.1** Hot dip galvanized, minimum ASTM A123 or A153 Class D, as applicable.

**1.9.1.2** Painted with zinc-rich primer (undercoat and finish coat) or equivalent paint system.

**1.9.2** Cold-formed steel members shall be 55 percent aluminum-zinc alloy coated per ASTM A792/A792M standard in accordance with the American Iron and Steel Institute (AISI) S240 Table A4-1, CP 90 coating designation.

**1.9.3** Cables shall be stainless steel or galvanized per ASCE 19 Chapter 6.

**1.9.4** All exposed steel fasteners, including cast-in-place anchor bolts/rods, shall be stainless steel (Type 304 minimum), hot dip galvanized (ASTM A153 Class D minimum or ASTM F2329), or protected with corrosion-preventive coating that demonstrated no more than 2 percent of red rust in minimum 1,000 hours of exposure in salt spray test per ASTM B117. Zinc-plated fasteners do not comply with this requirement. Examples of proprietary coatings that do comply with the 1000-hour requirement include, but are not necessarily limited to Quik Guard by Simpson, Kwik-Cote by Hilti, Stalgard by Elco, vistaCorr by SFS intec, etc.

**1.9.5** Post-installed anchors used for exterior exposure shall comply with the requirements of the evaluation report.

### **1.10 Sheet Index**

The PC drawings shall include a sheet index. When a PC includes multiple major options such that not all sheets are applicable to a given site-specific project application based on the option being used, the sheet index shall include check boxes. When the PC drawings are incorporated

---

## PRE-CHECK (PC) DESIGN CRITERIA FOR OPEN FABRIC SHADE STRUCTURES: 2022 CBC

into a site-specific application, the submitted sheets will be identified by marking the check boxes (i.e., it is not necessary to strike out sheets that are not applicable). See PR 07-01 Appendix E for additional information.

### 1.11 Stamps

The PC drawings shall include the following:

1.11.1 2022 CBC PC Stamp per PR 07-01 Section 6.1.

1.11.2 Two blank areas on each PC sheet title block as indicated in *PR 18-04: Electronic Plan Review for Design Professionals of Record*, Section 1: one for the PC Identification Stamp and one for the future site-specific Identification Stamp.

### 1.12 Structural Product Acceptance

All structural products shall meet the requirements set forth in *IR A-5: Acceptance of Products, Materials, and Evaluation Reports*. Code-based engineering calculations to support a manufactured product will be considered.

### 1.13 California Green Building Standards Code and California Energy Code

The PC design shall comply with the mandatory measures of the California Green Building Standards Code and the California Energy Code.

## 2. FABRIC STRUCTURES

### 2.1 Structural Analysis Software

The design professional shall provide to DSA sufficient documentation to verify and substantiate input and output of all software used for design, including but not limited to:

2.1.1 Electronic file.

2.1.2 Input and output data in PDF file format.

2.1.3 Description of input and output including schematic framing plans, member and joint labeling, member loads, checks of elements, cables, connections, etc.

2.1.4 Derivation of loads.

2.1.5 Hand calculations to approximate and validate analysis results for cable forces and reactions.

2.1.6 Narrative summary of key results.

2.1.7 Validation by hand calculation or other software upon request.

2.1.8 Explanation, read-me file, or user guide for unusual modeling upon request.

### 2.2 Fabric Does Not Provide Lateral Resistance

Fabric materials shall not be considered as contributing to the primary lateral resistance of the structure. The design must account for forces acting upon fabric as transferring directly to the supporting structure.

### 2.3 Membrane Properties

The breaking strengths (in both the warp and fill directions) and the modulus of elasticity of the membrane shall be determined via testing. Provide published values for the specified fabric in accordance with American Society of Civil Engineers Standard 55: Tensile Membrane Structures (ASCE 55), Section 2.4.2. An evaluation report per IR A-5 is not required. Test

---

## **PRE-CHECK (PC) DESIGN CRITERIA FOR OPEN FABRIC SHADE STRUCTURES: 2022 CBC**

reports or published values are not required to be stamped by a California registered professional engineer or structural engineer.

### **2.4 Membrane Design**

The design of membrane components shall utilize load combinations and strength reduction factors per ASCE 55 Table 4-2. Allowable stress increase is not permitted. The membrane resistance shall be checked per ASCE 55 Section 4.6.1.

### **2.5 Cables and Cable Connections**

Cables and cable connections shall be designed in accordance with ASCE 19. Cables shall be specified per ASTM A1023/A1023M.  $S_a$  shall be greater than the required strength ( $S_r$ ).

### **2.6 Catenary Action and Forces Transmitted to Support Elements**

The catenary action of fabric and cables (where occur) shall be considered in the design of open fabric shade structures. Catenary action must be accounted for in the design of the catenary elements themselves and when considering their reactions on supporting elements. Specifically, the design shall include large-deflections analysis that accounts for fabric properties and behavior when considering the forces transmitted to the supporting cables, beams, and columns. Such analysis is usually accomplished using software to perform nonlinear finite element analysis. The design must include the tensile reaction forces from the fabric and/or cables to the supporting structure (i.e., columns and beams). See Section 2.1 above for software verification requirements.

In a tensile membrane structure, the catenary is the curved shape developed at the boundary of the fabric or by any cable support member in tension between points of restraint.

### **2.7 Full-scale Testing in Lieu of Analysis**

As an alternate method to stress analysis, the fabric may be subjected to full-scale load testing in accordance with the load combinations of ASCE 55 Table 4-2 increased by a safety factor.

The safety factor used for testing shall be  $1/(\beta \cdot L_t)$ , where  $\beta$  is the strength reduction factor per ASCE 55 Table 4-2 and  $L_t$  is the life-cycle factor per ASCE 55 Section 4.4.2. The testing protocol is subject to DSA approval.

## **3. GRAVITY LOAD DESIGN**

### **3.1 Dead and Live Loads**

**3.1.1** The design for dead loads shall comply with ASCE 55 Section 4.2.2.

**3.1.2** The design for superimposed loads shall comply with ASCE 55 Section 4.2.3.

**3.1.3** The design for live loads shall be in accordance with CBC Section 1607A and Table 1607A.1.

### **3.2 Snow load**

As required by ASCE 55 Section 4.2.4, snow loads shall be in accordance with CBC Section 1608A and American Society of Civil Engineers Standard 7: Minimum Design Loads and Associated Criteria for Buildings and Other Structures (ASCE 7), Chapter 7. The design shall consider deflection of the membrane under accumulated snow and other loads. The shape of the fabric shade structure must be covered by ASCE 7 for the snow load calculation. Shapes not covered by ASCE 7 may be used, provided research and testing is used as basis for design. See ASCE 55 Section C4.2.

---

**PRE-CHECK (PC) DESIGN CRITERIA FOR OPEN FABRIC SHADE STRUCTURES:  
2022 CBC**

**3.2.1** The design information section shall state snow and ice loads accounted for in the PC design. The PC drawings shall indicate 0 (zero) pounds per square foot if the design does not account for snow or ice loads.

**3.2.2** If the structure is designed for snow load, the design information section of the PC drawings shall include a note the same as or similar to the following: "Site application design professional and DSA plan reviewer shall verify the structure to be located at least xx feet from any adjacent higher structure" where the distance "xx" is calculated and stated by the PC applicant. See ASCE 7 Section 7.7. If the horizontal separation from a higher structure is less than 20 feet and six times the vertical dimension separating the roofs, snow drift analysis shall be provided by the PC applicant, and the project is not eligible for OTC submittal.

**3.2.3** The effective seismic weight shall include snow load per ASCE 7 Section 12.7.2.

### **3.3 Ponding**

If the shape or configuration of the structure does not maintain positive drainage from all areas of the roof, then the design must consider ponding in accordance with ASCE 55 Section 4.3.4.

## **4. LATERAL LOAD DESIGN**

### **4.1 Wind Load**

As required by ASCE 55 Section 4.2.5, wind loads shall be in accordance with CBC Section 1609A and ASCE 7.

**4.1.1** For open fabric shade structures with "sail" shapes, the design of the Main Wind Force Resisting System (MWFRS) may be based on ASCE 7 Chapter 27 when the following conditions are met. "Sail" shape in this section refers to fabric areas supported by cables in the absence of rigid structural members in the plane(s) of the fabric.

**4.1.1.1** If the fabric profile does not have a vertical slope change greater than 7.5 degrees along any catenary curve, the shape is permitted to be considered "flat" rather than a hyperbolic paraboloid and may utilize the monoslope provisions of ASCE 7 Figure 27.3-4. See Figure 4.1(a) below.

**4.1.1.2** When the fabric profile has a vertical slope change greater than 7.5 degrees in one direction and has a primary catenary curve (e.g., ridge or trough) for which the vertical slope change does not exceed 7.5 degrees, the shape is permitted to be considered a "pitched" or "troughed" roof and may utilize the associated provisions of ASCE 7 Figure 27.3-5 or 27.3-6, respectively. See Figure 4.1(b) and (c) below.

**4.1.1.3** For fabric profiles that do not comply with Section 4.1.1.1 or 4.1.1.2 above, the design professional may propose an alternate methodology for the determination of wind loads subject to DSA approval in consideration of the specific profile proposed. Applicants proposing the use of an alternate analysis and design methodology that was not previously used in a prior approved version of the PC are encouraged to present the proposed methodology to DSA in a preapplication meeting. Refer also to Section 4.1.4 below.

## PRE-CHECK (PC) DESIGN CRITERIA FOR OPEN FABRIC SHADE STRUCTURES: 2022 CBC

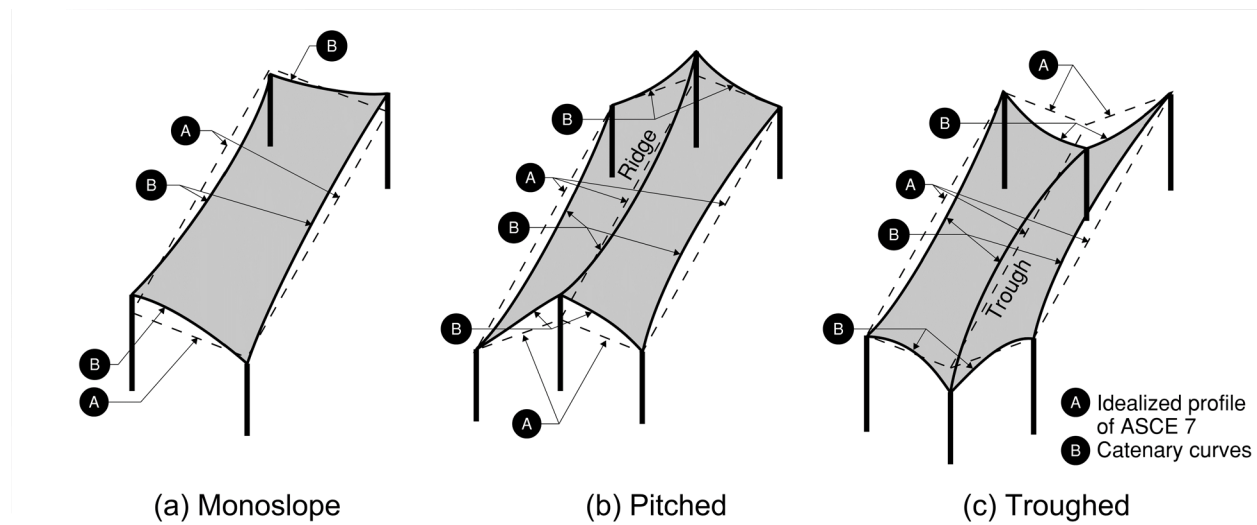

**Figure 4.1: Sail Shapes**

**4.1.2** Open fabric shade structures with roof shapes meeting the prescriptive requirements of ASCE 7 (i.e., hip, gable, monoslope, etc.) shall use a gust factor  $G$  per ASCE 7 Section 26.11. The structures will not be considered as dynamically sensitive if the structural calculations contain a statement from the structural engineer of record that the structure is not dynamically sensitive for purposes of determining the gust factor.

**4.1.3** Open fabric shade structures with roof shapes not covered by ASCE 7 or where the MWFRS is cables guyed to the ground may need to be considered as dynamically sensitive for calculation of gust factor,  $G$ . The flexibility of all surfaces resisting wind loads shall be included as resisting elements in determining whether the structure is dynamically sensitive.

**4.1.4** Shapes not covered by ASCE 7 may be used, provided wind tunnel testing is used as basis for design. See ASCE 55 Section C4.2.

## 4.2 Seismic Load Criteria

**4.2.1** The seismic design criteria upon which the PC design is based shall be stated in the design information section of the PC drawings in accordance with PR 07-01 and CBC Section 1603A.1.5.

**4.2.2** If the design is based upon the maximum  $S_s$  and  $S_1$  values (as defined by ASCE 7 Section 11.3) occurring in the state of California, the PC can be used at any site in the state. The PC design may be based on other  $S_s$  and  $S_1$  values but doing so will limit the site locations where the PC can be used.

**4.2.3** The base shear is permitted to be calculated using a cap on the maximum design spectral response acceleration parameter value of  $S_{DS}$  in accordance with ASCE 7 Section 12.8.1.3, provided that *all* of the criteria therein are met.

**4.2.3.1** The PC design shall demonstrate compliance with the required criteria specific to the open fabric shade structure (e.g., no irregularities, period not exceeding 0.5 seconds, redundancy factor equal to 1.0, etc.). The PC drawings shall list these properties in the design information section. For the purpose of checking compliance with these criteria, the period shall be determined based on the actual properties of the structure, including foundation flexibility, and not use the approximate period in ASCE 7 Section 12.8.2.1.



---

## PRE-CHECK (PC) DESIGN CRITERIA FOR OPEN FABRIC SHADE STRUCTURES: 2022 CBC

**4.2.3.2** The design information section of the PC drawings shall also contain a note stating the site-specific limitations of the design based on the  $S_{DS}$  cap and requiring these be verified by the site-specific project applicant (e.g., Site Class E or F not allowed, RC I or II, etc.).

**4.2.3.3** Per PR 07-01 Appendix C, if a capped value of  $S_{DS}$  is used to determine  $C_s$ , the design information section shall list the  $S_{DS}$  (cap) used to determine  $C_s$  as well as the  $S_{DS}$  (no cap) used for verification of site-specific application and to determine other parameters such as non-structural component anchorage.

### 4.3 Ground Motion Hazard Analysis

The 2022 CBC adopts ASCE 7 with Supplement 3, which modifies Section 11.4.8. Due to the site-specific ground motion hazard analysis requirements of ASCE 7 Section 11.4.8, the seismic load criteria used for PC designs per Section 4.2 above for Site Class D and E shall consider the Exceptions of ASCE 7 Section 11.4.8, Items 1 and 2.

**4.3.1** The PC option for Site Class D shall include a note in the design information section the same or similar to the following: "Unless a site-specific ground motion hazard analysis is performed, the  $S_{M1}$  value increased by 50% shall be less than the design criteria stated herein."

**4.3.2** The PC option for Site Class E shall state in the design information section whether or not the PC design complies with the conditions of Exception 1 of ASCE 7 Section 11.4.8, Item 2.

### 4.4 Seismic Force Resisting System

Open fabric shade structures shall comply with ASCE 7 Chapter 12. These structures shall be designed as cantilevered column systems or other systems allowed per ASCE 7 Chapter 12. In accordance with ASCE 7 Table 12.2-1, the response modification coefficient (R) for cantilever column systems commonly used in open fabric shade structures is as follows:

**4.4.1** Steel special cantilever column systems:  $R = 2.5$ .

**4.4.2** Steel ordinary cantilever column systems:  $R = 1.25$ .

### 4.5 Drift

For open structures, there is no drift limit for RC I or II structures; however, there are drift limits for RC III structures per ASCE 7 Section 12.12.1 and CBC Section 1609A.1.2.

## 5. FOUNDATION

### 5.1 Vertical Allowable Soil Pressure

The PC design shall be based on the presumptive allowable soil bearing pressure corresponding to Class 5 soil in CBC Table 1806A.2 unless justified by a site-specific geotechnical report. In order to use values greater than that stated for Class 5 soil, a statement requiring a site-specific geotechnical report at the time of site application must be included in the design information section of the PC drawings.

An allowable stress increase in the presumptive load-bearing value is not permitted when using the allowable stress design load combinations per ASCE 7 Section 2.4. An allowable stress increase is permitted when using the alternative allowable stress load combinations per CBC Section 1605A.2 that include wind or seismic loads.

### 5.2 Lateral Bearing Pressure

The PC design shall be based on the presumptive lateral bearing pressure corresponding to Class 5 soil in CBC Table 1806A.2 unless justified by a site-specific geotechnical report. In order to use values greater than that stated for Class 5 soil, a statement requiring a site-specific

---

**PRE-CHECK (PC) DESIGN CRITERIA FOR OPEN FABRIC SHADE STRUCTURES:  
2022 CBC**

geotechnical report at the time of site application must be included in the design information section on the PC drawings.

The presumptive lateral bearing pressure may be increased in accordance with CBC Section 1806A.3.4. This increase is not permitted to lateral bearing values determined by a site-specific geotechnical evaluation. The design information section of the PC drawings shall clearly state if the lateral bearing pressure value used in the design has been increased per CBC Section 1806A.3.4.

**5.3 Foundation Design Load**

The design of foundation elements, including cast-in-place deep foundations (drilled piers) and shallow spread footings, and their connections shall be based on load combinations including the overstrength factor for cantilever column systems per ASCE 7 Section 12.2.5.2 and CBC Section 1617A.1.15.

**5.4 Cast-in-place Deep Foundation (Drilled Pier)**

**5.4.1** The PC design shall comply with CBC Section 1810A.3.9 if the column anchors at the top of the drilled pier (i.e., with base plate and anchor rods) or is partially embedded. See Sections 5.11 and 5.12 below. *BU 09-06: Minimum Reinforcement of Concrete Piers and Caissons Embedded with Steel Poles* can be applied if the steel column is fully embedded (i.e., to within six inches of the bottom of the drilled pier).

**5.4.2** See Section 5.7 below for drilled piers used in combination with shallow spread footings.

**5.4.3** In accordance with CBC Section 1810A.2.4, the depth of the drilled pier is permitted to be designed per CBC Section 1807A.3.2 if the drilled pier is assumed to be rigid.

**5.4.3.1** The drilled pier may be assumed to be rigid if the ratio of the specified depth (not the minimum depth required by CBC Section 1807A.3.2) to diameter is equal to or less than 8 and the California Geological Survey (CGS) does not otherwise require analysis per Section 5.4.3.2 below.

**5.4.3.2** When the drilled pier does not comply with Section 5.4.3.1 above, the design, including reinforcing, shall consider the nonlinear interaction of the drilled pier and soil (e.g., L-pile analysis or equivalent) per CBC Section 1810A.2.4 with consideration of group effects as required by CBC Section 1810A.2.5.

**5.4.4** The design information section shall include a note specifying the minimum clearance required between drilled piers when placing multiple open fabric shade structures adjacent to each other. The design of the drilled piers shall consider group effects per CBC Section 1810A.2.5 if applicable.

**5.4.5** For drilled piers with partial column embedment or a base plate and embedded anchor rods, transverse reinforcing shall comply with CBC Section 1810A.3.9.4.2 and American Concrete Institute (ACI) 318.

**Exception:** The transverse reinforcement (i.e., tie or spiral) spacing need not be less than listed in the subsections below when the drilled pier is assumed to be rigid per Section 5.4.3 above and the factored axial force is less than 10 percent of the specified concrete compressive strength multiplied by the gross area of the concrete section (i.e.,  $P_u < 0.10f'_cA_g$ ). This exception is only applicable to drilled piers supporting open fabric shade structures. This type of structure is lightly loaded and has a low ductility demand. These exceptions may not be extended to other types of structures.

---

**PRE-CHECK (PC) DESIGN CRITERIA FOR OPEN FABRIC SHADE STRUCTURES:  
2022 CBC**

**5.4.5.1** For drilled piers in soil categorized as Site Class A, B, C or D, provide transverse reinforcement spacing not to exceed the smallest of the following in the top 3d of the drilled pier (where “d” is the drilled pier diameter). Refer to Figures 5.4A and 5.4C in *IR PC-1: Pre-Check (PC) Design Criteria for Freestanding Signs, Scoreboards, and Ball Walls*.

**5.4.5.1.1** One quarter the drilled pier diameter:  $d/4$ .

**5.4.5.1.2** Six times the least Grade 60 longitudinal bar diameter:  $6d_b$ .

**5.4.5.1.3** Five times the least Grade 80 longitudinal bar diameter:  $5d_b$

**5.4.5.1.4** Six inches: 6”.

**5.4.5.2** For drilled piers in soil categorized as Site Class E, provide transverse reinforcement spacing not to exceed that required by Section 5.4.5.1 above in the top 7d of the drilled pier (where “d” is the drilled pier diameter). Refer to IR PC-1 Figures 5.4B and 5.4D. In consideration that 7d is 88 percent or more of the overall pier depth and the requirement of Section 5.4.5.4 below, it is recommended this transverse reinforcement spacing requirement simply be extended over the full depth of the drilled pier.

**5.4.5.3** For drilled piers in soil categorized as Site Class A, B, C, D, or E provide transverse reinforcement spacing not to exceed the smallest of the following in the remainder of the drilled pier except as required by Section 5.4.5.4 below. Refer to IR PC-1 Figures 5.4A, 5.4B, 5.4C, and 5.4D.

**5.4.5.3.1** One half the drilled pier diameter:  $d/2$ .

**5.4.5.3.2** Twelve times the least longitudinal bar diameter:  $12d_b$ .

**5.4.5.3.3** Twelve inches: 12”.

**5.4.5.4** For drilled piers in soil categorized as Site Class A, B, C, D, or E, transverse reinforcement spacing shall comply with Section 5.4.5.1 above at all depths within 7d above and below (where “d” is the drilled pier diameter) interfaces between hard/stiff and soft strata as required by ACI 318 Section 18.13.5.5.

**5.4.5.5** For drilled piers with partially embedded columns, the transverse reinforcement spacing shall not be greater than that required by Section 5.11.1 below.

## **5.5 Allowable Frictional Resistance and Uplift Capacity**

The allowable frictional resistance and uplift capacity used in the design of cast-in-place deep foundations (drilled piers) shall be included in the design information section. When a site-specific geotechnical report is not available, CBC Section 1810A.3.3.1.4 can be used to obtain an allowable frictional resistance value. Assume Class 5 soils as noted in Sections 5.1 and 5.2 above.

## **5.6 Ground Surface Condition**

When CBC Section 1807A.3.2 is utilized, asphalt pavement does not constitute a “constrained” condition and does not justify the use of CBC Equation 18A-2 or 18A-3 to determine the required drilled pier depth. Where the constrained condition is used with concrete pavement, the reaction shall be adequately resisted and justified by calculations. The construction necessary to resist this reaction shall be clearly detailed on the PC drawings.

## **5.7 Shallow Foundations**

Shallow spread footings shall be designed per CBC Chapter 18A and for stability in accordance with CBC Section 1605A.1.1. If an open fabric shade structure is supported by a combination of

## PRE-CHECK (PC) DESIGN CRITERIA FOR OPEN FABRIC SHADE STRUCTURES: 2022 CBC

deep foundation element(s) (e.g., drilled pier) and a shallow spread footing(s), all steel columns within the structure shall have the same height unless the column stiffness is accounted for in design.

### 5.8 Adjacent Slopes

The PC drawings shall specify minimum setback limits (values are required) of the structure relative to slopes per CBC Section 1808A.7. Alternatively, when delineated on the approved PC drawings, the required depth of the cast-in-place deep foundation (drilled pier) can be increased in accordance with Figure 5.8 below.

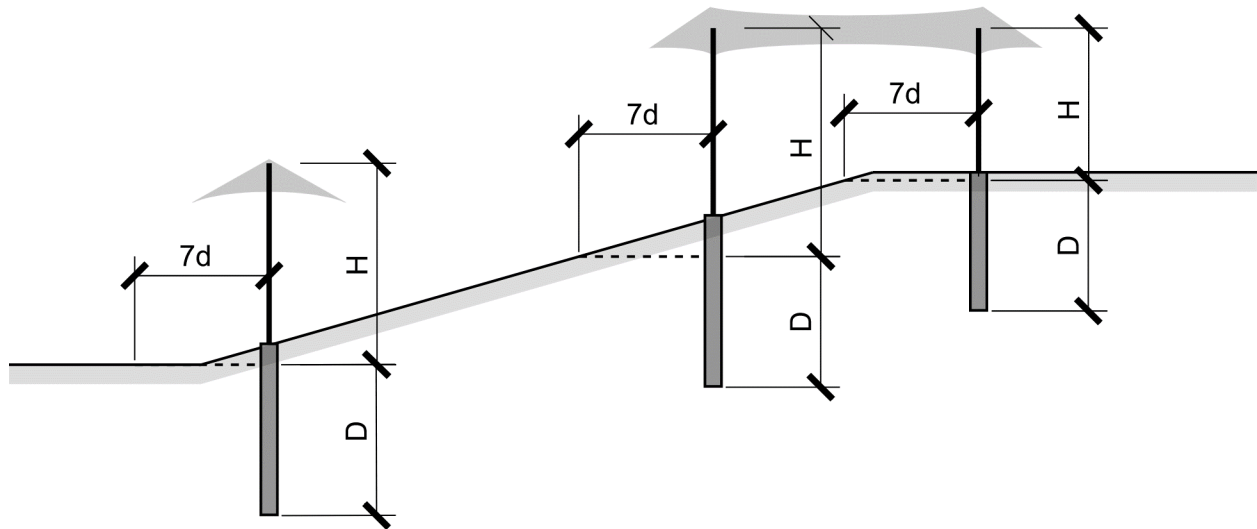

**Figure 5.8: Sloped Sites**

The pier depth shall be increased such the depth required by analysis (i.e., “D” designated in Figure 5.8) is provided below a horizontal plane projected from a horizontal distance seven times the pier diameter (i.e., “7d” designated in Figure 5.8). Additionally, design parameters dependent on column height shall be determined based on a theoretical column height starting from the same horizontal plane (i.e., “H” designated in Figure 5.8). If the setback limits are smaller than the CBC requires, a site-specific geotechnical report is required.

### 5.9 Liquefiable Soil or Site Class F

PC designs will not be approved with an option for construction on sites with liquefiable soil and/or categorized as Site Class F. If the site is not in a mapped liquefaction hazard zone, it may be presumed that no liquefaction hazard exists on that site unless a site-specific geotechnical report identifies such hazard. Refer to IR A-4 Section 4.

**Exception:** Open fabric shade structures 1,600 SF or less complying with requirements of IR A-4 Section 3.1.1.1.

### 5.10 Concrete Mix

In addition to those requirements dictated by the PC design, the concrete mix used in the foundation elements shall comply with the durability requirements of ACI 318 Section 19.3. The PC drawings shall account for the dependency of these durability requirements on site-specific characteristics.

---

**PRE-CHECK (PC) DESIGN CRITERIA FOR OPEN FABRIC SHADE STRUCTURES:  
2022 CBC**

**5.10.1** When the PC drawings do not require a site-specific geotechnical report that quantifies sulfate content in the soil, the PC drawings shall require a concrete mix complying with one of the following per ACI 318 Table 19.3.2.1.

**5.10.1.1** Maximum water/cement ratio of 0.45; minimum compressive strength of 4,500 pounds per square inch (psi); Type V cement plus pozzolan or slag cement complying with Footnote 7; and prohibition of admixtures containing calcium chloride.

**5.10.1.2** Maximum water/cement ratio of 0.40; minimum compressive strength of 5,000 psi; Type V cement complying with Footnote 8; and prohibition of admixtures containing calcium chloride.

**5.10.2** When the PC drawings require a site-specific geotechnical report that quantifies sulfate content in the soil, the PC drawings shall clearly state the exposure class for each category (i.e., F, S, W and C) or combination thereof the PC design is approved for. The maximum water/cement ratio, minimum compressive strength, cementitious material requirements, and admixture limitations shall be stated on the PC drawings for each approved case.

**5.10.3** Both approaches given in Section 5.10.1 and 5.10.2 above can be included on the PC drawings as alternate options in accordance with Section 1.4 above.

**5.10.4** The PC drawings shall include a note requiring that concrete exposed to freezing-and-thawing cycles be air entrained per ACI 318 Section 19.3.3.

### **5.11 Partially Embedded Columns**

When cantilevered columns are partially embedded into cast-in-place deep foundation (drilled pier), BU 09-06 is not applicable.

**5.11.1** The load transfer mechanism of partially embedded columns shall include the design of both the column and drilled pier ties or spiral. The transverse reinforcement size and spacing shall be sufficient to transfer the required force based on a rational method and accepted principles of engineering mechanics.

**5.11.2** The minimum column embedment depth into the drilled pier shall be the greater of the following:

**5.11.2.1** Seven times the least dimension of column section.

**5.11.2.2** Minimum development length of the longitudinal drilled pier reinforcing.

**5.11.3** All embedded columns into drilled piers shall have a mechanical connection to resist uplift. American Institute of Steel Construction (AISC) 360 Section I6 provides acceptable criteria for demonstrating the adequacy of the load transfer from the partially embedded column to the drilled pier.

**Exception:** For steel columns embedded into the drilled pier 4 feet or more, it is permitted to assume an allowable bond stress of 25 psi between the steel column and concrete. The upper 12 inches of the column embedment shall be disregarded and no increase in this allowable bond stress is permitted for wind or seismic loads.

### **5.12 Column Base Connection**

**5.12.1** The embedment depth of the anchor rods shall be sufficient to lap with the longitudinal drilled pier reinforcement, when applicable. The lap length shall be based on developing the longitudinal reinforcement beyond the projected failure plane of the anchor rod heads. Refer to IR PC-1 Figures 5.4A, 5.4B, 5.4C, and 5.4D and ACI 318 Figure R17.5.2.1a. The lap length is

---

**PRE-CHECK (PC) DESIGN CRITERIA FOR OPEN FABRIC SHADE STRUCTURES:  
2022 CBC**

not permitted to be reduced based on providing reinforcement beyond that required for the applied loads.

**5.12.2** Anchor rods shall be designed for combined shear and tension. If the maximum grout thickness between the top of the foundation and bottom of the base plate exceeds two times the anchor rod diameter, the anchor rods shall be designed for bending in combination with tension and shear. Refer to Telecommunication Industry Association (TIA) 222-H Section 4.9.9 and *AISC Design Guide 1: Base Plate and Anchor Rod Design*. When oversized holes are used in the base plate, the design shall comply with CBC Section 2204A.4.

**6. ACCESS COMPLIANCE REQUIREMENTS**

Accessibility requirements shall comply with CBC Chapter 11B. Appropriate details shall be provided on plans to assure compliance with all applicable code requirements.

**7. FIRE AND LIFE SAFETY REQUIREMENTS****7.1 Type of Construction**

Specify type of construction per CBC Chapter 6 in the design information section.

**7.2 Total Area of Structure**

Specify total area of structure in the design information section on the coversheet and demonstrate that the total area is compliant with the allowable area criteria as determined per CBC Section 506.2 based on type of construction and proposed occupancy classification(s).

**7.3 Use and Occupancy Classification(s)**

Specify proposed use and occupancy classification(s) per CBC Chapter 3 in the design information section on the coversheet.

**7.4 Special Construction Requirements**

Fabric shade structures shall comply with the applicable provisions of CBC Sections 3102 and 3105.

**7.5 Membrane Fabric**

Fabric material shall comply with CBC Sections 3102.3.1, 3105.3, and CCR, Title 19, Division 1, Chapter 8.

**7.6** For fabric shade structures see *IR 31-1: Construction and Installation of Free-standing, Open-sided Shade Structures on Public School and Community College Campuses*.

---

**REFERENCES:**

2022 California Code of Regulations (CCR) Title 24  
Part 1: California Administrative Code (CAC)  
Part 2: California Building Code (CBC)  
Part 6: California Energy Code  
Part 11: California Green Building Standards Code

---

This IR is intended for use by DSA staff and by design professionals to promote statewide consistency for review and approval of plans and specifications as well as construction oversight of projects within the jurisdiction of DSA, which includes State of California public schools (K–12), community colleges and state-owned or state-leased essential services buildings. This IR indicates an acceptable method for achieving compliance with applicable codes and regulations, although other methods proposed by design professionals may be considered by DSA.

This IR is subject to revision at any time. Please check DSA's website for currently effective IRs. Only IRs listed on the webpage at <https://www.dgs.ca.gov/dsa/publications> at the time of project application submittal to DSA are considered applicable.

## PRE-CHECK (PC) DESIGN CRITERIA FOR OPEN FABRIC SHADE STRUCTURES: 2022 CBC

### APPENDIX A: SITE-SPECIFIC APPLICATION GUIDE

The following notes are provided as a guide to assist design professionals and DSA plan reviewers when preparing and reviewing site-specific project applications that incorporate PC fabric shade structures designed in accordance with this IR. This Appendix is not intended to be an all-inclusive list of design and submittal requirements but rather is an aid to identify aspects of the design criteria described in this IR of particular interest to its site application.

- Verify site-specific suitability of the PC including all parameters in PL 07-02 Section 3.
- Verify site-specific requirements of PL 07-02 Section 4 are met.
- Review the site-specific form DSA 103 in comparison with the example form DSA 103 and for any exemptions from the required structural tests and special inspections. Refer to Section 1.3 above for additional information.
- Verify Risk Category (RC) of the site-specific design is compliant with the design information section of the approved PC. RC determination is based on the Occupant Load (OL) of the site-specific code analysis and Occupant Load Factors (OLF) per CBC Table 1004.5. Refer to Section 1.6 above for additional information. The following are some examples of common Use and Occupancy classifications with associated OLF and sizing limits for RC II:
  - Lunch Shelter | Assembly Use 'A-2': OLF = 15 square foot (SF)/person or if a combination of table-bench seating is provided, 18 inches/person measured along linear bench length. Group 'A' structures with OLF of 15 must not exceed (300x15=) 4,500 SF for RC II.
  - Shade Structure | Concentrated Assembly, Group 'A': OLF = 7 SF/person or if fixed seating is provided, calculate per CBC Section 1004.6. Group 'A' structures with OLF of 7 must not exceed (300x7=) 2,100 SF for RC II.
  - Shade Structure | Outdoor Instructional Use, Group 'E': OLF = 20 SF/person. Group 'E' structures with OLF of 20 must not exceed (250x20=) 5,000 SF for RC II.
  - Shade Structure over Playground Equipment, Group 'E' (classified same as the campus): OLF = 20 SF/person shall be utilized for purposes of assigning a risk category. Group 'E' structures with OLF of 20 must not exceed (250x20=) 5,000 SF for RC II.
  - Shade Structure over Parking: Group 'S-2' or 'U' (determined by design professional): OLF = 200 SF/person. Structures assigned this Use are unlikely to exceed RC II unless utilized for emergency vehicles.
  - Regardless of size, if a structure that would otherwise qualify as RC II provides shelter for emergency vehicles or equipment; or provides required access to, required egress from or shares life safety components with an RC III or IV building, the more restrictive RC must be applied. See CBC Section 1604A.5.1.
- If the site is located in a flood zone other than Zone X, verify a validation letter from a geotechnical engineer is provided. Refer to Section 1.7 above for additional information.
- If the site is classified as Site Class D or E, verify if the Exception of ASCE 7 Section 11.4.8 is met or if a site-specific ground motion hazard analysis is required. Refer to Section 4.3 above for additional information.

---

**PRE-CHECK (PC) DESIGN CRITERIA FOR OPEN FABRIC SHADE STRUCTURES:  
2022 CBC**

- In addition to the requirements of PL 07-02 Section 3.1.3, if the PC design is based on a capped  $S_{DS}$  value per ASCE 7 Section 12.8.1.3 verify the site-specific criteria are met. Refer to Section 4.2.3. above for additional information. |
- If drilled pier foundations are used and multiple structures are placed at a site, verify the site-specific drawings comply with the clearance requirements listed on the PC drawings. Refer to Section 5.4.4 above for additional information. |
- If drilled pier foundations are used and the constrained ground surface condition option is applied, verify the site-specific drawings comply with the ground surface requirements defined on the PC drawings. Note: Asphalt concrete is not acceptable. Refer to Section 5. 6 above for additional information. |
- If the shade structure foundation contains both drilled piers and shallow spread footings, verify all columns are the same height unless differing column heights are specifically allowed by the PC drawings. Refer to Section 5.7 above for additional information. |
- If structures are placed adjacent to a slope, verify the site-specific drawings comply with the setback and/or pier embedment requirements defined on the PC drawings. Refer to Section 5.8 above for additional information. |