

ATTACHMENT A13

OFFICE OF PUBLIC SCHOOL CONSTRUCTION STAKEHOLDER MEETING June 11, 2026

PROPOSED AMENDMENTS TO THE SCHOOL FACILITY PROGRAM FOR THE CREATION OF A LEAD IN WATER TESTING AND REMEDIATION PROGRAM

PURPOSE

To discuss and receive stakeholder feedback resulting from Assembly Bill (AB) 247, the Kindergarten through Grade 12 Schools and Local Community College Public Education Facilities Modernization, Repair, and Safety Bond Act of 2024 (Proposition 2), which was approved by a majority of California's voters on November 5, 2024. This discussion and resulting stakeholder feedback will inform regulatory development and implementation of a new Lead in Water Testing and Remediation Program established by Proposition 2.

AUTHORITY

See Attachment A13a.

BACKGROUND

With the passage of Proposition 2, Education Code (EC) Section 17077.60 was added to allow the State Allocation Board (Board) to award grants in funding cycles, wherein the first funding cycle could provide funding to school districts requesting funding for lead in water testing. The second funding cycle could provide funding to school districts that demonstrate that testing resulted in lead levels in excess of 15 parts per billion (PPB).

The following is a summary of the new statute:

EC Section 17077.60(a) states that the Board shall provide a grant to test lead in water outlets used for drinking or preparing food on school sites constructed prior to January 1, 2010, serving any of kindergarten through grade 12 (K-12), and for the remediation of any water outlets with lead levels in excess of 15 PPB. Additionally, this subdivision states that the Board will release apportionments to school districts with approved applications using the applicable school district's local and state contribution percentages pursuant to EC Section 17074.16 for modernization projects, which is a 60 percent state share and 40 percent local share before any local funding adjustment made.

EC Section 17077.60(b) states that a school district applying for funding to test lead levels in water outlets used for drinking or preparing food on a school site is required to test all outlets on the school site, with the exception of any that have been tested or replaced since January 1, 2010. This section states that any test results shall be provided to the Office of Public School Construction (OPSC) and the community water system that serves the school district.

BACKGROUND (cont.)

EC Section 17077.60(c) states that a school district can apply for funding to remediate lead levels through replacement of a water outlet used for drinking or preparing food if the test results indicate lead levels for that water outlet exceed 15 PPB. Once the remediation efforts are completed, this subdivision states that additional testing of the water outlet is required to ensure lead levels have fallen below 15 PPB.

EC Section 17077.60(d) states that the Board shall establish funding cycles to allocate funds. If there are funds available at the conclusion of the funding cycles, the Board may adopt regulations to provide grants to replace any pipes or fixtures that are contributing to elevated lead levels if lead levels do not fall below 15 PPB after additional testing has been performed, pursuant to EC Section 17077.60(c).

EC Section 17077.60(e) states that the Board may consider setting a maximum amount on the grant to be provided for testing and remediation.

At its January 22, 2025 meeting, the Board set aside the maximum amount of Modernization bond authority for the Lead in Water Testing and Remediation Program permitted under statute. Thus, \$115 million of Proposition 2 Modernization bond authority is set aside to establish the Lead in Water Testing and Remediation Program for purposes of testing and remediation of lead in water outlets used for drinking and preparing food within public K-12 schools.

Recent California Legislative History Regarding Lead Testing

In 2006, AB 1953 (Chapter 853, Statutes of 2006) amended Section 116875 of the California Health and Safety Code to read that, beginning January 1, 2010, no person shall introduce into commerce any pipe, pipe or plumbing fixture, or fixture used to convey or dispense water for human consumption through drinking or cooking that is not lead free, as defined in subdivision (e) of Health and Safety Code Section 116875. This includes kitchen and bathroom faucets, and any other devices used to convey or dispense water for human consumption.

In 2016, Section 116276 was added to the Health and Safety Code by Senate Bill (SB) 828 (Chapter 29, Statutes of 2016). This section led the State Water Resources Control Board (SWRCB) to create the Division of Drinking Water (DDW) and establish the Drinking Water for Schools Grant Program. These initiatives aimed to enhance both access to and the quality of drinking water in public schools, particularly related to lead testing. SB 828 also provided \$9.5 million in grant funding for the Drinking Water for Schools Grant Program. Then, SB 862 (Chapter 449, Statutes of 2018) added \$6.8 million for this program.

BACKGROUND (cont.)

According to the SWRCB's guidelines for the Drinking Water for Schools Grant Program, one of the eligible types of projects to receive this funding includes the "installation, replacement, or repairs of drinking water fixtures and associated plumbing appurtenances that are necessary to address lead contamination identified pursuant to the Lead Sampling of Drinking Water in California Schools program and that requires a corrective action."

STAFF ANALYSIS/DISCUSSION

In 2017, AB 746 (Chapter 746, Statutes of 2017) added Section 116277 to the Health and Safety Code, which established a requirement for community water systems to test lead levels in drinking water at all California public K-12 school sites constructed before January 1, 2010 and to complete the required testing by July 1, 2019. As of July 1, 2019, DDW completed this initiative. According to the SWRCB website, following the July 1, 2019 testing initiative, DDW encourages schools to test for lead in their water supply by requesting assistance from their community water system as a requirement of the 2017 permit amendment. A permit amendment in this context refers to a change made by the SWRCB to the operating permit issued to community water systems, adding new requirements they must follow. DDW issued the 2017 permit amendments to community public water systems serving K-12 schools requiring them to collect and analyze up to five water samples at each K-12 school that requested sampling. Once requested, the water system was required to sample within 90 days. If elevated lead levels were detected (over 15 PPB), the public water system/SWRCB provided technical assistance.

Both AB 746 (Chapter 746, Statutes of 2017) and AB 247 (Chapter 81, Statutes of 2024) indicate their provisions apply to public K-12 school sites that were constructed before January 1, 2010. As previously indicated, Health and Safety Code Section 116875, as amended by AB 1953 (Chapter 853, Statutes of 2006), prohibits the introduction into commerce of any pipe, pipe or plumbing fitting, or fixture intended to convey or dispense water for human consumption that is not "lead free" as defined in statute effective January 1, 2010.

According to the United States Environmental Protection Agency's (U.S. EPA) *3Ts for Reducing Lead in Drinking Water in Schools and Child Care Facilities* (Attachment A13b), most lead in school and child care drinking water results from corrosion of older plumbing materials containing lead, wherein interior lead solder and lead pipe and lead solder brass fittings, valves, and various drinking water outlets such as water fountains and faucets are the primary contributors to elevated lead levels. Most common sources of lead in drinking water are from lead pipes, faucets, and fixtures. Additionally, per the Reduction of Lead in Drinking Water Act of 2011, "lead-free" is defined as not more than a weighted average of 0.25 percent lead when used with respect to the wetted surfaces of pipes, pipe fittings, plumbing fittings, and fixtures.

STAFF ANALYSIS/DISCUSSION (cont.)

Lead in Water Testing and Remediation Program Considerations

OPSC recognizes that there are many considerations related to the development of regulations for EC Section 17077.60, which designates bond authority for both testing and remediation of water outlets used for drinking or preparing food with lead levels in excess of 15 PPB.

OPSC has several questions and concepts outlined below to open the conversation and receive stakeholder feedback related to the development of regulations for the Lead in Water Testing and Remediation Program under the School Facility Program (SFP). OPSC anticipates hosting additional stakeholder meetings to address stakeholder feedback and provide proposed regulations.

Below are some questions and answers for stakeholder consideration and input related to the Lead in Water Testing and Remediation Program.

1. Who is eligible to request testing and remediation funding under the Lead in Water Testing and Remediation Program?

School districts and county offices of education may apply. EC Section 17077.60 was added under the Chapter 12.5, the SFP. EC Section 17070.15(q) defines a school district for SFP purposes to also include county offices of education. EC Section 17077.60 specifies grants are for school sites serving kindergarten, or any of grades 1 to 12, inclusive, on school sites that were constructed before January 1, 2010. School districts are eligible to submit a request for funding to test water outlets used for drinking or preparing food on a school site. These applications will be school site-specific.

Any school site constructed on or after January 1, 2010 shall not be eligible to request funding through this program. Additionally, according to EC Section 17077.60(b)(1), school districts and county offices of education applying for lead testing funding are required to test all water outlets used for drinking or preparing food at the school site, except outlets that have been tested or replaced since January 1, 2010. For example, a school district can apply for funding to conduct lead testing at all water outlets used for drinking or preparing food at a school site constructed in 2005, except any such outlet that was tested or replaced since January 1, 2010, such as those tested under the DDW permit action wherein water systems assisted schools with sampling up to five locations at each school site.

Applicants that have demonstrate elevated lead levels exceeding 15 PPB from a water outlet used for drinking or preparing food at a school site, are eligible to request remediation funding and subsequent testing funds for any remediated water outlets, pursuant to EC Section 17077.60(c).

STAFF ANALYSIS/DISCUSSION (cont.)

2. What is the proposed overall process for a school district seeking Lead in Water Testing and Remediation Program assistance?

OPSC anticipates holding a minimum of two funding cycles for this program. In the first funding cycle, applicants may submit a request to test water outlets used for drinking or preparing food on a school site constructed before January 1, 2010. During the second funding cycle, applicants may submit a funding request for purposes of replacing water outlets used for drinking or preparing food on a school site constructed before January 1, 2010 that have lead levels in excess of 15 PPB. Applicants receiving funding in the second funding cycle would also receive funding for subsequent testing following remediation efforts to ensure lead levels have fallen below 15 PPB.

If there are funds available at the conclusion of the first two funding cycles for purposes of testing and water outlet remediation, respectively, the Board may hold a third funding cycle to replace any pipes or fixtures that are contributing to elevated lead levels if lead levels do not fall below 15 PPB after additional testing has been performed in the second funding cycle.

3. Will I be required to provide a local match for this assistance?

Yes. According to EC Section 17077.60(a)(2), the Board shall release funds to school districts consistent with the required matching funds from local sources for modernization projects, which is a state share of 60-65 percent and a local matching share of 35-40 percent, based upon a points-based local funding adjustment.

4. If I cannot provide some or all of my local match, is the Financial Hardship Program available for both testing and remediation funding?

Yes, applicants who cannot provide all or some of their local matching share may request Financial Hardship assistance on each respective application.

5. What is the definition of a “water outlet”?

According to the U.S. EPA (Attachment A13b), a water outlet is a location where water may be accessed for consumption, such as a drinking fountain, water faucet, or tap. A drinking water fountain is a fixture connected to the water supply, such as fountains without central chillers, fountains with central chillers, water coolers, bottled water fillers, etc. A chiller is a central refrigeration unit providing cold water to some drinking water fountains. A faucet is a valved outlet device attached to a pipe that normally serves a sink or tub fixture. A faucet discharges hot and/or cold water for a variety of consumptive uses, including drinking, cooking, and washing. The term “faucet” is used interchangeably with the term “tap.”

STAFF ANALYSIS/DISCUSSION (cont.)

6. What is lead remediation?

Lead remediation actions that can be covered under the second funding cycle of this grant as eligible expenditures are the removal and replacement of water outlets used for human consumption such as faucets, water fountains, and related components, pursuant to EC Section 17077.60(c)(1)

7. EC Section 17077.60(d) allows any remaining funds from water testing and remediation cycles to be used to replace piping or fixtures that cause lead levels above 15 PPB. What are some examples of piping or fixtures that might be replaced?

According to the U.S. EPA's definition of interior plumbing (Attachment A13b), interior plumbing is plumbing within the wall and upstream of the fixture, notably potable water pipes, which are pipes in a distribution system and in a building which carries water intended for human consumption. Potable water pipes would be able to be replaced, provided they distribute water to the water outlets that were tested, remediated, and still have elevated lead levels above 15 PPB from subsequent testing following remediation efforts.

8. Because the Board is required to establish funding cycles for the Lead in Water Testing and Remediation Program, how will funding be allocated between the funding cycles?

OPSC proposes setting aside a designated amount for the first cycle specifically for testing, and then a designated amount for the second cycle specifically for remediation.

At this time, out of the \$115 million set aside for this program, OPSC proposes to set aside \$20 million for the first cycle exclusively for testing, and \$95 million for the second cycle for both remediation and subsequent testing of water outlets used for drinking or food preparation that were remediated.

OPSC welcomes stakeholder feedback on this proposed delineation of available bond authority between the first two cycles.

9. Can costs related to previous testing of eligible water outlets and any remediation efforts that did not previously receive state funding be reimbursed by the Lead in Water Testing and Remediation Program?

OPSC acknowledges that within the SFP, there are programs that allow reimbursement of costs incurred on or after the enacting date of legislation. However, OPSC also acknowledges that this is a new program with a specific set aside of bond authority and specific criteria outlined in statute regarding testing and subsequent replacement of specified water outlets. Specifically, what

STAFF ANALYSIS/DISCUSSION (cont.)

is proposed within this stakeholder item is a first funding cycle distinctly for testing of specified water outlets at school sites, and a second funding cycle for purposes of the replacement of water outlets tested in the first cycle that exceed 15 PPB and subsequent testing to ensure that the water outlets test below the 15 PPB threshold.

As a result, OPSC is interested in stakeholder input with respect to reimbursement under this new program with the proposed funding cycles.

10. How will a school district apply for funding for testing?

OPSC proposes that school districts are required to submit the following, in addition to a proposed application for lead testing, in order to have a complete application package:

- A site map of the school site that indicates the eligible construction date of all buildings constructed before January 1, 2010.
- An inventory accompanying the site map that reflects the location and number of water outlets used for drinking water and preparation of food not tested or replaced after January 1, 2010.
- If available, actual costs, bids, or a cost estimate associated with testing the specified water outlets.

11. How will a school district apply for funding for purposes of remediating water outlets used for human consumption?

Once a district tests all water outlets used for purposes of drinking water and the preparation of food not tested or replaced after January 1, 2010 on an eligible school site, if the school district has submitted a testing application with OPSC or has documented water outlets used for human consumption indicating lead levels in excess of 15 PPB, the school district may submit a funding request for purposes of remediation and re-testing of the affected water outlets. OPSC proposes that applicants would submit a cost estimate in likeness to the *Facility Hardship Cost Estimate* (Form SAB 58-01) that entails a unit cost breakdown for replacement of the affected water outlets.

12. Statute requires that test results are reported to both OPSC and the community water system that serves the school district. What is a community water system, and what if an applicant is not a part of one, such as in the case of a school site served by a well?

California Health and Safety Code Section 116275(i) defines a community water system as, "a public water system that serves at least 15 service connections used by

STAFF ANALYSIS/DISCUSSION (cont.)

yearlong residents or regularly serves at least 25 yearlong residents of the area served by the system.”

To qualify for the Lead in Water Testing and Remediation Program, EC Section 17077.60(b)(2) states that a school district shall provide the test results to OPSC and the community water system that serves the school district.

In the event that an applicant school district is not served by a community water system, the applicant should provide the test results to OPSC. OPSC is considering an appropriate state-level government entity to additionally receive test results for school sites served by a well system, such as the SWRCB.

13. How will the Lead in Water Testing and Remediation Program interact with the Facility Hardship Program?

This program is standalone from the Facility Hardship Program. However, if a district has previously received state funding associated with remediating lead in water outlets specifically used for human consumption, the district shall indicate the affiliated application number on the Lead in Water Testing and Remediation Program application in order to ensure there is no duplication of state funds associated with remediation efforts.

14. What type of outlets may be tested within this program?

According to DDW’s Sampling Guidance document (Attachment A13c), the Drinking Water for Schools Grant Program selected up to “five of the busiest locations used for drinking and cooking to be sampled and tested,” inclusive of “faucets, fountains, coolers, bubblers, bottle filling stations, and filtered water dispensers located on the exterior and interior of buildings, including those located in hallways, playgrounds, classrooms, and cafeterias... Large industrial sinks designed for washing and not intended to be used as a source of water for drinking and cooking should not be included.”

OPSC proposes using similar criteria for purposes of determining what type of water outlets may be tested. Specifically, water outlets such as faucets, fountains, coolers, bubblers, bottle filling stations, and filtered water dispensers used for drinking and the preparation of food.

15. What is an example of what the testing process looks like?

According to the U.S. EPA’s guidelines for reducing lead in drinking water in schools (Attachment A13b), there are two steps associated with testing water outlets:

Step One: An initial first-draw sample is taken from water outlets used for purposes of drinking water or the preparation of food. The first-draw sample is

STAFF ANALYSIS/DISCUSSION (cont.)

representative of water that may be consumed at the beginning of the day or after infrequent use, wherein the highest concentration of lead may be found after overnight stagnation. This sample should be collected before the facility opens and before the water outlets have been used (the U.S. EPA suggests an 8-18 hour stagnation period). A 250-mL sample should be taken at each water outlet used for drinking water or the preparation of food.

Step Two: If elevated lead levels are demonstrated in any of the water outlets from step one, a 30-second flush sample is taken after water has been running from the fixture for 30 seconds to determine if lead is coming from the fixture itself or from interior plumbing.

16. EC Section 17077.60(e) states that the Board may establish a maximum amount for the grant to be provided for both testing and remediation (replacement of water outlets). Will OPSC propose a maximum grant amount, and if so, what might that amount be? Additionally, will there be any prioritization for applications?

As discussed under number eight above, there is \$115 million available for purposes of the Lead in Water Testing and Remediation Program. At this time, OPSC proposes designating \$20 million for testing in the first funding cycle, and \$95 million for replacement of water outlets and subsequent testing within the second funding cycle. A third funding cycle will occur should there be any remaining authority following the first and second funding cycles.

That being said, OPSC recognizes that there are many considerations with respect to the establishment of a maximum grant amount, and is highly interested in stakeholder input with respect to the proposal of maximum grant amounts.

An example of a way that maximum grant amounts could be established could be as follows:

- A tiered maximum grant amount per school site, wherein small school sites with 200 pupils or fewer would have a set maximum grant amount, medium-sized school sites with 201 to 999 pupils receive a higher maximum grant amount, and school sites with 1,000 or more pupils receive the highest maximum grant amount. This option assumes school sites with higher pupil enrollment have larger numbers of eligible water outlets.

STAFF ANALYSIS/DISCUSSION (cont.)

In conjunction with potential maximum grant amounts, OPSC recognizes that should demand in one or more respective funding cycles exceed available authority, that the development of prioritization criteria for applications could assist with determining applicants that may move forward. For instance, some SFP programs include prioritization criteria pertaining to the geographic distribution of school districts receiving an apportionment. OPSC welcomes stakeholder feedback regarding the potential development of prioritization criteria for this new program.

17. How will the substantial progress and accountability requirements work for testing and remediation?

OPSC proposes to establish regulations with substantial progress, expenditure reporting, grant agreement, and audit requirements for applicants that receive an apportionment of funds for testing and/or remediation of lead levels in excess of 15 PPB, similar to the requirements that are currently in place for Modernization apportionments.

18. To participate in the Lead in Water Testing and Remediation Program, does a district have to submit a Five-Year School Facilities Master Plan?

As a condition of participating in the SFP, school districts must submit a Master Plan, or an updated Master Plan, approved by the governing board of the school district, pursuant to EC Section 17070.54. As the Lead in Water Testing and Remediation Program is under the SFP statutory authority, school districts are subject to the Master Plan requirement.

OPSC will present further information on this topic at a subsequent stakeholder meeting.

NEXT STEPS

OPSC welcomes any feedback from stakeholders regarding the proposed concepts.

Staff will review any feedback obtained in today's meeting and anything received through close of business on **Friday, June 26, 2026**, and will address those suggestions in the next public meeting on this topic.

To submit written feedback after today's meeting, please email your suggestions to the OPSC Communications Team at OPSCCommunications@dgs.ca.gov.

AUTHORITY**Education Code (EC) Section 17077.60 – Testing and Remediation of Lead Levels in Water at Schoolsites states:**

(a) (1) With funds made available for this purpose, the board shall provide a grant to test for lead in water outlets used for drinking or preparing food on schoolsites serving kindergarten or any of grades 1 to 12, inclusive, that were constructed before January 1, 2010, and for the remediation of any water outlets with lead levels in excess of 15 parts per billion.

(2) The board shall release disbursements to school districts with approved applications for purposes of this article, to the extent state funds are available, consistent with the applicable school district's local and state contribution percentages determined pursuant to Section 17074.16. Subject to the availability of funds, the board shall apportion funds to an eligible school district only upon review of evidence that the required local matching funds, for the applicable school district determined pursuant to Section 17074.16, have been expended by the school district for the project, have been deposited in the county fund, or will be expended by the school district by the time of completion of the project, and upon review of evidence that the school district has entered into a binding contract for the completion of that project.

(b) (1) A school district that applies for funding to test lead levels in water outlets used for drinking or preparing food shall be required to test all outlets on the schoolsite, except outlets that have been tested or replaced since January 1, 2010.

(2) A school district shall provide the test results to the Office of Public School Construction and the community water system that serves the school district.

(c) (1) A school district may request a grant for the replacement of a water outlet used for drinking or preparing food if the test results indicate lead levels for that water outlet exceed 15 parts per billion.

(2) Additional testing shall be required upon completion of the remediation efforts specified in paragraph (1) to ensure that lead levels have fallen below 15 parts per billion.

(d) The board shall establish funding cycles for allocation of funds. If funds are available at the conclusion of the funding cycles, the board may adopt regulations to provide grants to replace any pipes or fixtures that are contributing to the elevated lead levels if lead levels do not fall below 15 parts per billion after additional testing has been performed, as specified in paragraph (2) of subdivision (c).

(e) The board may consider setting a maximum amount on the grant to be provided for testing and remediation.

(Added by Stats. 2024, Ch. 81, Sec. 22. (AB 247) Effective July 3, 2024. Operative November 6, 2024, pursuant to Sec. 30 of Ch. 81.)

AUTHORITY (cont.)**EC Section 101412 states in part:**

(a)(2)(C) Of the amount allocated under this paragraph, up to one hundred fifteen million dollars (\$115,000,000) shall be available to address the remediation of lead in water pursuant to Article 10.7 (commencing with Section 17077.60) of Chapter 12. 5 of Part 10 of Division 1 of Title 1.).

Health and Safety Code Section 116275 states in part:

...
 (i) "Community water system" means a public water system that serves at least 15 service connections used by yearlong residents or regularly serves at least 25 yearlong residents of the area served by the system.
 ...

Health and Safety Code Section 116875 states:

(a) No person shall use any pipe, pipe or plumbing fitting or fixture, solder, or flux that is not lead free in the installation or repair of any public water system or any plumbing in a facility providing water for human consumption, except when necessary for the repair of leaded joints of cast iron pipes.

(b)(1) No person shall introduce into commerce any pipe, pipe or plumbing fitting, or fixture intended to convey or dispense water for human consumption through drinking or cooking that is not lead free, as defined in subdivision (e). This includes kitchen faucets, bathroom faucets, and any other end-use devices intended to convey or dispense water for human consumption through drinking or cooking, but excludes service saddles, backflow preventers for nonpotable services such as irrigation and industrial, and water distribution main gate valves that are two inches in diameter and above.

(2) Pipes, pipe or plumbing fittings, or fixtures that are used in manufacturing, industrial processing, for irrigation purposes, and any other uses where the water is not intended for human consumption through drinking or cooking are not subject to the requirements of paragraph (1).

(3) For all purposes other than manufacturing, industrial processing, or to convey or dispense water for human consumption, "lead free" is defined in subdivision (f).

(c) No person engaged in the business of selling plumbing supplies, except manufacturers, shall sell solder or flux that is not lead free.

(d) No person shall introduce into commerce any solder or flux that is not lead free unless the solder or flux bears a prominent label stating that it is illegal to use the solder or flux in the installation or repair of any plumbing providing water for human consumption.

(e) For the purposes of this section, "lead free" means not more than 0.2 percent lead when used with respect to solder and flux and not more than a weighted average of 0.25 percent when used with respect to the wetted surfaces of pipes

AUTHORITY (cont.)

and pipe fittings, plumbing fittings, and fixtures. The weighted average lead content of a pipe and pipe fitting, plumbing fitting, and fixture shall be calculated by using the following formula: The percentage of lead content within each component that comes into contact with water shall be multiplied by the percent of the total wetted surface of the entire pipe and pipe fitting, plumbing fitting, or fixture represented in each component containing lead. These percentages shall be added and the sum shall constitute the weighted average lead content of the pipe and pipe fitting, plumbing fitting, or fixture.

(f) For the purposes of paragraph (3) of subdivision (b), "lead free," consistent with the requirements of federal law, means not more than 0.2 percent lead when used with respect to solder and flux and not more than 8 percent when used with respect to pipes and pipe fittings. With respect to plumbing fittings and fixtures, "lead free" means not more than 4 percent by dry weight after August 6, 2002, unless the department has adopted a standard, based on health effects, for the leaching of lead.

(g)(1) All pipe, pipe or plumbing fittings or fixtures, solder, or flux shall be certified by an independent American National Standards Institute (ANSI) accredited third party, including, but not limited to, NSF International, as being in compliance with this section.

(2) (A) The certification described in paragraph (1) shall, at a minimum, include testing of materials in accordance with the protocols used by the Department of Toxic Substances Control in implementing Article 10.1.2 (commencing with Section 25214.4.3) of Chapter 6.5 of Division 20.

(B) The certification required pursuant to this subdivision shall not interfere with either the department's exercise of its independent authority to protect public health pursuant to this section, or the Department of Toxic Substances Control's exercise of its independent authority to implement Article 10.1.2 (commencing with Section 25214.4.3) of Chapter 6.5 of Division 20.

(3) It is the intent of the Legislature that this subdivision only provide guidance and assistance to the entities that use an independent ANSI accredited third party to demonstrate compliance with this section. Any tests developed by an independent ANSI accredited third party in accordance with this subdivision shall have no weight of authority under California statute.

(4) Notwithstanding paragraph (1), the department shall retain its independent authority in administering this article.

(h) This section shall become operative on January 1, 2010. The requirement described in subdivision (g) shall not be construed in any manner as to justify a delay in compliance with the lead-free standard set forth in subdivision (e).



3Ts for Reducing Lead in Drinking Water in Schools and Child Care Facilities

A Training, Testing, and Taking Action Approach

Revised Manual



This 2018 version of *3Ts for Reducing Lead in Drinking Water in Schools and Child Care Facilities* is a revision of the October 2006 version. The U.S. Environmental Protection Agency (EPA) is in the process of revising the Lead and Copper Rule (LCR). The requirements discussed in this document are based on the current LCR.

Please visit <https://epa.gov/safewater/3Ts> for additional information.

Disclaimer

This manual contains recommendations on how to address lead drinking water in schools and child care facilities; these recommendations are suggestions only and are not requirements. This manual does, however, also contain an overview of federal regulatory requirements concerning lead in drinking water that apply to public water systems. Some schools and child care facilities are regulated as “public water systems” but many schools and child care facilities receive water from a public water system and are not regulated under the Safe Drinking Water Act. The statutory provisions and regulations described in this document contain binding requirements that may apply to the school or child care facility if they are a public water system. In addition, this document describes federal statutory requirements that apply to all repairs and new installations of pipes, fittings, and fixtures in facilities providing water for human consumption. The general description here does not substitute for those laws or regulations; nor is this document a regulation itself. Also, many states (or tribes) and localities have different, more stringent requirements than EPA’s, some of which may apply to schools and child care facilities even if they are not a public water system. Therefore, schools and child care facilities should not rely solely on this guidance for compliance information.

Office of Water (4606M)

EPA 815-B-18-007

October 2018

Contents

Introduction	4
Establishing a Lead Testing Program – 3Ts Checklist	6
Module 1: Communicating the 3Ts	7
Developing a Communication Plan	7
Module 2: Learning About Lead in Drinking Water	13
Health Effects of Lead	13
Sources of Lead	14
How Lead Gets in Drinking Water	15
Your Facility and the Public Water System Relationship	16
How Lead in Drinking Water is Related	17
Module 3: Planning your 3Ts Program	19
Review Your Records	19
Establish Partnerships	20
Assigning Roles	25
Module 4: Developing a Sampling Plan	29
Conduct a Walkthrough	29
Determine Sampling Locations	31
Selecting a Laboratory for Sample Analysis	32
Determine Your Sampling Frequency	33
Understanding the Sampling Procedures	34
Module 5: Conducting Sampling and Interpreting Results	37
2-Step Sampling at the Tap	37
Sampling Dos and Don'ts	41
Module 6: Remediation and Establishing Routine Practices	42
Immediate Response	42
Short-Term Control Measures	43
Permanent Control Measures	45
Follow-Up Sampling	46
Considerations for Replacement Activities	47
Establishing Routine Practices	48
Module 7: Recordkeeping	51
Keep Records	51
Appendix A: Glossary of Terms	52
Appendix B: Lead Water Coolers Banned in 1988	55
Appendix C: Develop a Code System for Samples	58
Appendix D: Detailed Fixture Evaluation	59
Appendix E: Preservation of Samples	70
Appendix F: Example Sampling Field Form	72
Appendix G: Plumbing Profile	73

Introduction

This document is intended to serve as a resource to help schools and child care facilities implement a voluntary program for reducing lead in drinking water. The approach is focused on three key steps:

- **TRAINING** school and child care officials to raise awareness of the 3Ts program and summarize the potential causes and health effects of lead in drinking water.
- **TESTING** drinking water in schools and child care facilities to identify potential lead problems.
- **TAKING ACTION** to reduce lead in drinking water.

Children are most susceptible to the effects of lead because their bodies are still undergoing development and they tend to absorb more lead from the environment. The adverse health effects of lead exposure include reduced IQ and attention span, learning disabilities, poor classroom performance, hyperactivity, behavioral problems, impaired growth, and hearing loss. **The only way to know if there is lead in drinking water is to test.**

There is no federal law requiring testing of drinking water in schools and child care facilities, except for schools and child care facilities that own and/or operate their own public water supply and are thus regulated under the Safe Drinking Water Act (SDWA). Some states, tribes, and local jurisdictions have established their own laws, regulations, or guidance for testing drinking water lead levels in schools and/or child care facilities. School and child care facilities should reach out to their state to find out what laws or regulations may apply to them. EPA suggests that school and child care facilities implement programs for reducing lead in drinking water as part of their overall plans for maintaining healthy learning environments. Safe and healthy environments foster healthy children and may improve student performance.

Even when water entering a facility meets all federal and state public health standards for lead, older plumbing materials in schools and child care facilities may contribute to elevated levels lead in their drinking water. The potential for lead to leach into water increases the longer the water remains in contact with leaded plumbing materials. As a result, facilities with intermittent water use patterns, such as schools, are more likely to have elevated lead concentrations in

WHAT IS YOUR WATER SOURCE?

It is important to be familiar with the source of your drinking water. Some schools and child care facilities are served by nearby public or private water systems, while others operate their own water systems and are regulated under the Safe Drinking Water Act.

Facilities that operate their own drinking water systems are required to comply with of regulations under the Safe Drinking Water Act, including regulations pertaining to lead in drinking water.

Whether or not your facility is classified as a public water system, it is important to establish a program that includes routine testing and evaluations to limit lead contamination, as well as routine practices to ensure the you are providing safe drinking water to students and staff.

drinking water. Implementing the 3Ts will help schools and child care facilities to identify potential problems with plumbing systems and materials so that targeted remediation efforts can be taken. This document will also assist you in communicating with parents, teachers, and the public. Transparency and communication are key to developing a successful program for reducing lead in drinking water.

In addition to this document, there are a number of supplemental resources included as appendices, which contain information and tools to support 3Ts programs.

Access the full toolkit here: <https://epa.gov/safewater/3Ts>

- [Appendix A: Glossary of Terms](#)
- [Appendix B: Lead Water Coolers Banned in 1988](#)
- [Appendix C: Develop a Code System for Samples](#)
- [Appendix D: Detailed Fixture Evaluation](#)
- [Appendix E: Preservation of Samples](#)
- [Appendix F: Example Sampling Field Form](#)
- [Appendix G: Plumbing Profile](#)

3Ts Toolkit

<https://epa.gov/safewater/3Ts>

Build a team and make a plan! Protecting school and child care facility drinking water is a group effort and you will need to have a plan for who you will work with, how you will test, and how you will address elevated lead that may be found. Make sure you are transparent in your communications with your community. The 3Ts toolkit includes modules and helpful resources you can use to implement a successful program!



Module 1

Communicating the 3Ts



Module 2

Learning About Lead in Drinking Water



Module 3

Planning Your 3Ts Program



Module 4

Developing a Sampling Plan



Module 5

Conducting Sampling & Interpreting Results



Module 6

Remediation & Establishing Routine Practices



Module 7

Recordkeeping

Establishing a Lead Testing Program – 3Ts Checklist

The 3Ts toolkit assists you with the steps needed to create a program to reduce children’s exposure to lead in drinking water. Utilizing the 3Ts toolkit along with clear communication will help ensure a successful 3Ts Program.

Before sampling, facilities should establish a plan on how they will respond to their sample results to protect the school or child care facility population from lead in drinking water. You should consider potential partners, funding options, and how frequent testing will occur.



Communication Plan: Telling parents and staff about your lead monitoring program will demonstrate your commitment to protecting children and staff health.

Communicating early and often about your testing plans, results, and next steps will build confidence in your facility’s ability to provide a safe environment for students and staff.

The steps in the checklist are intended to help you learn about lead in drinking water, develop a program, test for lead, communicate the results, and take remediation actions where needed. The checklist includes things to consider in the TRAINING, TESTING, and TAKING ACTION sections of the 3Ts, as well as important COMMUNICATION and RECORDKEEPING items. This checklist is designed to provide easy-to-follow steps. You may not have to complete all the steps or follow the steps in the exact order presented to have an effective program. Your 3Ts program should be tailored for your school or child care facility.

Find the 3Ts Checklist here:
<https://epa.gov/safewater/3Ts>





Module 1: Communicating the 3Ts

Module 1

Module 2

Module 3

Module 4

Module 5

Module 6

Module 7

Developing a Communication Plan

At the heart of an effective communication plan is preparation and coordination to deliver information swiftly, professionally and consistently. Telling parents and staff about your 3Ts Program will demonstrate your commitment to protecting children and staff health. Communicating early and often about your testing plans, results, and next steps will build confidence in your ability to provide a safe environment.

When developing your communication plan:

- Take the initiative to communicate with your community
- Make sure your information is honest, accurate, and comprehensive
- Speak with one consistent voice
- Anticipate questions and concerns and address them proactively
- Be positive and forthcoming
- Keep your audiences up-to-date as new information becomes available

Helpful Tip...

To support engagement with the community and build trust, it is important to begin communication *before testing starts* and be open and transparent throughout the process.

Follow these recommended steps and utilize the templates in *3Ts Toolkit* to develop a successful and proactive communication plan.

STEP 1: Get Your Team Together

Assemble a team with technical and communications expertise. Draw from internal resources as well as professionals and leaders in your community. Designate a spokesperson to make announcements, respond to questions, and conduct interviews in order to ensure the accuracy and consistency of public information.

You can learn more about other roles in your lead testing program in the [Assigning Roles Section](#).

Fill out the chart below to get started building your team. Note, some people may have more than one role.

- Module 1
- Module 2
- Module 3
- Module 4
- Module 5
- Module 6
- Module 7

Description	Lead	Back-Up
3Ts Program Communication Contact: This person will act as the point of contact for your 3Ts Program and help coordinate the communication efforts.		
Partner Liaison Contact: This person will communicate with partners as the 3Ts Program progresses to ensure everyone is kept in the loop.		
Website and Social Media Contact: This person will make sure websites and social media stay up to date with the latest information.		
Public Hotline: Will you have a website or hotline for people to use to get more information? This person can monitor this to ensure questions and concerns are being responded to.		
Communication of Lead Health Risks: You should work with your health department to communicate lead health risks and information about blood lead testing for children.		

STEP 2: Create a Contact List

Having names, phone numbers, and email addresses at your fingertips is vital, especially when a quick response is necessary. Create a contact list and update it regularly. It should include task force members as well as fact-finding and communications contacts, including:

- School Superintendent
- School Board Members
- Civic Leaders
- Local Public Health Officials
- Head of Building Maintenance/Custodial Services
- State Department of Education
- State Department of Health
- State Drinking Water Program
- EPA Regional Office
- Utility/Water Supplier
- Media (Newspaper, TV, Radio, Web, and Newswire Outlets)

STEP 3: Identify Your Target Audiences

Generally, there are six primary audiences or interested parties involved in the control of lead in drinking water.

1. **School or Child Care Facility Community:** Employees, students, and parents should be informed and involved from the beginning of the process.
2. **Building Community:** The building community includes people other than those included in the school or child care facility community who may use the building for other functions (e.g., local community groups, school board members). Members of the building community probably do not utilize the building as frequently as the members of the school or child care facilities community, but they should still be kept informed and up-to-date regarding lead in the drinking water.
3. **Larger Community:** The larger community may consist of local residents and businesses in the school or child care facility's district or town. The local and regional media can serve as a conduit for information for the larger local community. It is important that you be prepared to generate accurate news releases. The spokesperson or task force should be prepared to respond to interview requests with accurate and consistent information.
4. **Local Community Organizations:** Local health officials, such as health officers, environmental health specialists, doctors, and nurses, can help you and your community understand health risks associated with elevated lead levels in drinking water. Local environmental community organizations may have an interest and potential assistance or resources for schools and child care facilities. The same may apply for the Lead Poisoning Prevention Program.
5. **State Drinking Water Programs:** State drinking water programs are responsible for ensuring that public water systems comply with the state and federal regulations regarding lead in drinking water. States may be able to provide guidance on or technical assistance with communication plan, health risks, and identifying other lead sources.
6. **Drinking Water Community:** Public water systems comprise the regulated drinking water community, and they are responsible for complying with all national and state drinking water standards. The public water system that serves your facility can provide technical information to support your program and can provide information to the community about what the system is doing to minimize lead in drinking water.

Module 1

Module 2

Module 3

Module 4

Module 5

Module 6

Module 7

STEP 4: Know Your Methods of Communication

The public notification methods described below can be applied independently or in combination to communicate about drinking water issues and the meaning of sampling program results.

Important note: You should also plan how you will provide information in other languages, as appropriate, or provide a contact name for non-English speakers to get more information.

Module 1

Module 2

Module 3

Module 4

Module 5

Module 6

Module 7

Methods of Communication	
	Press Release: A press release in the local newspaper or on local TV and radio stations can potentially reach a broad range of people. It is important that the release inform readers of how to obtain the sampling results and other lead information (as it pertains to drinking water) and include the phone number of the point(s) of contact.
	Letters/Fliers: Letters or fliers represent a direct and effective method of communicating 3Ts Program activities to parents/guardians and other members of a school, child care facility, or building community.
	Mailbox or Paycheck Stuffers: Mailbox and paycheck stuffers represent a direct and effective method of communicating 3Ts Program activities to your employees. Stuffers would contain information similar to that contained in a press release or letter/flier.
	Staff Newsletter: A notice contained in a staff newsletter is another option for directly and effectively communicating information about the 3Ts Program to employees.
	Presentations: Providing presentations at facility-related meetings can also serve as an effective means of communication. Relevant events include meetings of PTAs, faculty, and the school board.
	Email and Websites: Electronic communications are convenient for many parents. Websites can be updated frequently to quickly convey new information. Consider creating a separate email address for the 3Ts Program and providing it on the website and outreach materials. Email provides a quick, easy method for parents to ask questions, but responses must be timely to be effective.
	Social Media: Updates on the status of the 3Ts Program and information on regular activities can be provided to the public with ease via official social media accounts (e.g., Facebook, Twitter).

Module 1

Module 2

Module 3

Module 4

Module 5

Module 6

Module 7

STEP 5: Identify Times for Communicating

Timely dissemination of communication materials is of the utmost importance. Public communication efforts are less complicated and generate less conflict if those potentially affected are notified in advance of important issues and events.

At a minimum, EPA recommends that schools and child care facilities provide information to members of the local community, building community, and the larger community (if appropriate) at the following times:

- Before the lead in drinking water sampling program begins
- After obtaining the results of testing:
 - As soon as the results are available
 - When/if corrective measures are decided upon
 - If no corrective measures are appropriate because the lead levels are low
- In response to periodic interest in the program

STEP 6: Start Communicating!

Remember to communicate throughout your 3Ts Program, and work with partners and your communication team to be proactive and transparent. Recommended steps to help make your program a success:

- Launch an ongoing campaign of education and awareness, capitalizing on a variety of communication vehicles
- Prepare a fact sheet so that your spokesperson has accurate, up-to-date information about the status of your plumbing system and program.
- Post information on your website in a central location
- Make sure your communication materials include:
 - Details about the nature of the 3Ts Program
 - The results of the sampling program and plans for correcting any identified problems
 - Information on the public health effects and risks posed by lead in drinking water and the significance of lead other sources of lead such as food, air, dust, and soil
 - How and where individuals may seek blood-lead level testing if they are concerned
 - How families can increase their awareness of potential lead exposure in their homes and elsewhere

- Information about state-certified laboratories that can test home water for lead and other contaminants

Don't forget to maintain a record!

It is important to keep an ongoing record of public outreach and communication activities. By documenting outreach and the public's response, you can learn how to improve upon your public communication plan. For example, it might be helpful to keep a running log of questions received from the community that could be addressed in future communications.

Keep copies of past communication materials and dates they were sent out. Strong recordkeeping can prove to be helpful in illustrating what steps you have taken to notify the public of testing efforts and results.



Module 1

Module 2

Module 3

Module 4

Module 5

Module 6

Module 7

Additional Resources

View the 3Ts toolkit page for more resource to help you:

- Get your team together
- Create a contact list
- Identify your target area
- Know your methods of communication
- Identify timing for communication
- Start communicating!

All materials can be found here: <https://www.epa.gov/safewater/3Ts>



Module 2: Learning About Lead in Drinking Water

Module 1

Module 2

Module 3

Module 4

Module 5

Module 6

Module 7

Health Effects of Lead

Lead is a toxic metal that is harmful to human health. There is no safe blood lead level for children. In the human body, toxic lead can substitute for healthy calcium, which is a mineral that strengthens the bones. Lead is carried in the bloodstream and can harm the nervous system and brain. What is not excreted is absorbed into the bones, where it can collect for a lifetime.

The only way to determine a child's lead level is to have the child's blood tested. Contact a health provider to learn more about blood lead testing.

Young children are especially susceptible to lead exposure, because of their frequent hand-to-mouth activity, and their metabolism—their bodies absorb metals at a higher rate than the average adult does. Children's nervous systems are still undergoing development and thus are more vulnerable to the effects of toxic agents.

Pregnant and nursing staff should also be aware of the harmful risks of lead exposure to nursing infants and the developing fetuses of pregnant women. Mothers who have had exposure to lead in the past may store lead in their bones. Lead may be released from bones during pregnancy and lactation. Lead in drinking water can be a significant contributor to overall exposure to lead, particularly for infants whose diet consists of liquids made with water, such as baby food, juice, or formula.

Lead can affect almost every organ and system in the body. The central nervous system is particularly sensitive to lead, especially in children. Lead also damages the kidneys and the reproductive system. Even low blood levels of lead (those below 5 micrograms per deciliter ($\mu\text{g}/\text{dL}$)) have been associated with reduced IQ and attention span, learning disabilities, poor classroom performance, hyperactivity, behavioral problems, impaired growth, and hearing loss. Because childhood lead exposure often occurs with no immediate symptoms, it frequently goes unrecognized. The degree of harm from lead exposure depends on a number of factors including the frequency, duration and level of the exposure(s) and individual susceptibility factors (e.g., age, previous exposure history, nutrition, and health). In addition, the degree of harm depends on one's total exposure to lead from all sources in the environment—air, soil, dust, food, paint, consumer products, and water.

Sources of Lead

Lead is distributed in the environment through both natural and man-made means. Sources of lead exposure include the following:

- **Lead-based paint.** The most common sources of lead exposure for children are chips and particles of deteriorated lead paint. Although children may be exposed to lead from paint directly by swallowing paint chips, they are more often exposed to lead in house dust or soil contaminated by leaded paint. Lead paint chips can be ground into tiny pieces that become part of the dust and soil in and around homes. This usually occurs when leaded paint deteriorates or is subject to friction or abrasion (as on doors, windowsills, and window wells). In addition, lead can be dispersed when paint is disturbed during demolition, remodeling, paint removal or preparation of painted surfaces for repainting.
- **Lead in water.** Typically, lead in water occurs through corrosion of plumbing products containing lead.
- **Lead in the air** typically comes from industrial activities.
- **Lead in soil.** In most cases, lead deposits in soils around roadways and streets and homes come from past emissions from automobiles using leaded gas, together with lead paint chips and dust.
- **Lead from industrial activities.** Industrial workers can bring lead home on their clothes and shoes.
- **Lead in consumer products and food.** Lead may be found in some imported candies, medicines, dishes, toys, jewelry, and plastics.

Module 1

Module 2

Module 3

Module 4

Module 5

Module 6

Module 7



Air



Consumer Products



Paint



Soil



Industry



Drinking Water

The U.S. government has taken important steps over the past several decades to dramatically reduce new sources of lead in the environment:

- Banning the manufacture and sale of leaded paint.
- Phasing out lead additives in gasoline.
- Encouraging the phase-out of lead seams in food cans.
- Banning the sale of plumbing for drinking water that are not "[lead-free](#)."
- Limiting lead content in children's products.
- Banning lead-lined water coolers.
- Regulating lead in the nation's drinking water systems

Module 1

Module 2

Module 3

Module 4

Module 5

Module 6

Module 7

How Lead Gets in Drinking Water

Source Water

Lead is rarely present in the source water for the nation's drinking water supplies (i.e., untreated water from streams, rivers, lakes, or underground aquifers that is used to supply private wells and public drinking water). While lead can enter source water from contaminated runoff or water pollution, treatment plant technologies can remove lead from these sources.

Through Corrosion

Corrosion can release lead from pipes, solder, fixtures, and other plumbing materials that the water comes in contact with on its way from the water treatment system to the tap. The extent to which corrosion of plumbing materials occurs can affect the amount of lead that is present in the drinking water. Most lead in school and child care facility drinking water results from corrosion of older plumbing materials containing lead. Interior lead solder (commonly used until 1988) and lead pipe and lead solder, leaded brass fittings, valves, and various drinking water outlets (e.g., water fountains and faucets) that contain lead materials are the primary contributors. It is also important to note that brass plumbing components can contain lead.

The occurrence and rate of corrosion depend on the nature of the source water, the corrosion control practices at the water system, and the age of the plumbing materials in the building. For information on how chemical and physical conditions can be controlled to reduce lead in drinking water, contact the state drinking water program, which is typically housed in the state department of health or the department of environmental protection.

- Module 1
- Module 2
- Module 3
- Module 4
- Module 5
- Module 6
- Module 7

Particulate Lead

Particles of lead in drinking water, may result from physical corrosion of lead distribution system and interior plumbing components. Physical disturbances (e.g., construction), pipe replacement, and connection of new fixtures can cause the release of lead particles from system and plumbing components. This release can result in temporary, but significant, increases of lead levels in the water. Lead particles may also collect in the low-lying sections of pipe or behind faucet and fixture screens, increasing risk of exposure. Not all analysis methods account for particulate lead. For example, some field analyzer methods are not designed to account for particulate lead. See [Selecting a Laboratory for Sample Analysis](#) for more information on laboratory analysis of lead in water.

Your Facility and the Public Water System Relationship

As illustrated in Exhibit 1 below, once the water enters the distribution system – the network of pipes that carry water to homes, businesses, schools, and child care facilities in the community – the water may come into contact with lead. Some communities have lead components in their distribution systems, such as lead joints in cast iron mains, service connections (or service lines), and goosenecks or pigtails, which connect the water main to service lines. These components may be owned by the water supplier, or they may be owned by the school or child care facility. In addition, the drinking water may come into contact with plumbing materials that contain lead once the water enters the building.

Exhibit 1. Potential Sources of Lead in Schools

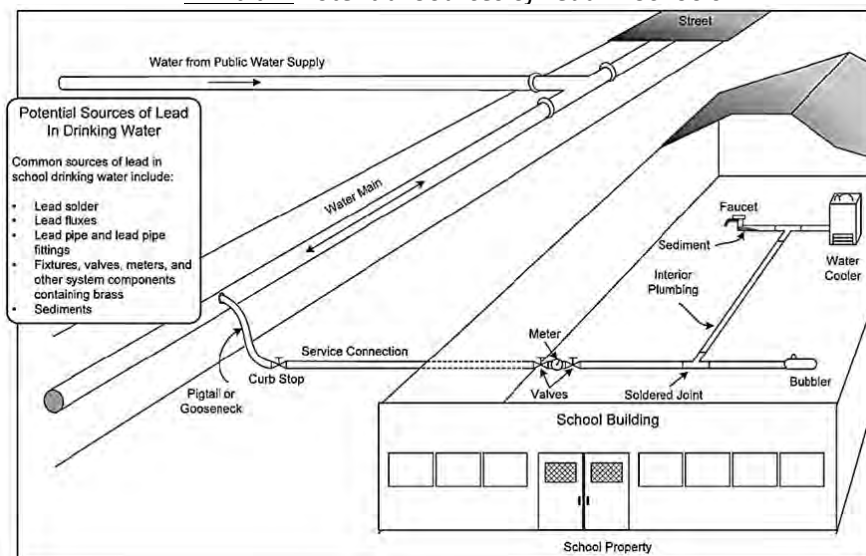

If the public water system finds unacceptable levels of lead during sampling under the Lead and Copper Rule (LCR), the public water system may have to provide centralized treatment or take other actions to minimize the corrosion of lead into the water (see [How Lead in Drinking Water is Regulated](#) below). However, centralized treatment by a public water system does not guarantee that corrosion of lead from plumbing will not occur within buildings served by the public water system, such as schools. It is important to note that the lead testing protocol used by public water systems is aimed at identifying system-wide problems rather than problems at outlets in individual buildings.

Module 1

Module 2

Module 3

Module 4

Module 5

Module 6

Module 7

How Lead in Drinking Water is Regulated

Lead is regulated in public drinking water systems under a federal regulation known as the Lead and Copper Rule. This regulation was initially issued in 1991 and, in part, requires water systems to test for lead and copper and to take actions that reduce corrosivity and protect public health.

Nearly all states have a drinking water office that implements the Safe Drinking Water Act (SDWA). Questions regarding the regulation of drinking water may be directed to the appropriate state drinking water program office or state licensing agency.

Picture of a Scratch on
a Lead Service Line



Requirements addressing lead in water include specific provisions in:

- THE SDWA LEAD BAN (1986):** A requirement that only “lead-free” materials be used in new plumbing and in plumbing repairs. In the 1986 ban, “lead-free” meant that solders and flux may not contain more than 0.2 percent lead, and pipes and pipe fittings may not contain more than 8.0 percent lead. It is likely that lead pipes and high-lead solder and fluxes continued to be used until 1988 in several states and territories, and until 1989 or 1990 in a few states, but other state or local governments may have imposed related lead-ban standards prior to 1988.
- THE LEAD CONTAMINATION CONTROL ACT (LCCA) (1988):** The LCCA is aimed at the identification and reduction of lead in drinking water at schools and child care facilities, including the recall of drinking water coolers with lead lined tanks and the publication of a list of drinking water coolers that were not “lead

free” as defined by the LCCA (no more than 8% lead for components that come into contact with water and no more than 0.2% percent lead for solder, flux, or storage tank interior that comes into contact with water).

- **THE LEAD AND COPPER RULE (1991):** A regulation by EPA to control the amount of lead and copper in water supplied by public water systems through corrosion control treatment, and other measures. Modifications were made to the Lead and Copper Rule in 2000 and 2007 to include revised requirements on demonstrating optimal corrosion control, monitoring, and reporting, treatment processes, public education, customer awareness, and lead service line replacement.
- **THE REDUCTION OF LEAD IN DRINKING WATER ACT (2011):** This act further reduced lead in pipes, pipe fittings, plumbing fittings, and fixtures to a weighted average of 0.25 percent. The act also redefined “lead-free” under the SDWA as not containing more than 0.2 percent lead when used with respect to solder and flux and not more than a weighted average of 0.25 percent lead when used with respect to the wetted surfaces of pipes, pipe fittings, plumbing fittings, and fixtures.

Module 1

Module 2

Module 3

Module 4

Module 5

Module 6

Module 7





Module 3: Planning Your 3Ts Program

Module 1

Module 2

Module 3

Module 4

Module 5

Module 6

Module 7

When planning your 3Ts Program, it is important to reach out to the public water system, state and local offices, parents, teaching staff, and other impacted stakeholders to establish partnerships. These partnerships will:

- Provide a better understanding of current lead control resources in the area.
- Offer partners who may be able to provide guidance to a new program.
- Create a platform for communicating any program updates to local and state offices and the community.

After you have a better understanding of how the program will operate in relation to current state and local efforts and what resources are available from internal and external stakeholders, it will be easier to identify individuals who can fill particular roles and make the program a success.

Use the [3Ts Checklist](#) to understand the recommended steps to implement a testing program for lead in school or child care drinking water.

Review Your Records

Identify and review records to determine if monitoring has previously been conducted at the school or child care facility. Some schools and child care facilities conducted voluntary monitoring in cooperation with state or local officials in response to the 1988 LCCA. Other schools and child care facilities may have sampled for lead in response to state requirements or local concerns. This information will be useful in filling out the plumbing profile questionnaire (provided in [Appendix G](#)), a tool that may be used to help determine whether lead is likely to be a problem in a school or child care facility. Records should also be reviewed to determine whether remediation actions have already been taken. For example, have water fountains with lead-lined coolers been replaced? See [Appendix B](#) for a listing of banned water coolers. While these records may not make additional testing or remediation unnecessary, they will help to prioritize efforts and make them more efficient.

If testing or remediation was conducted in response to the 1988 LCCA, it may have taken place 30 years ago or more. If current staff are not familiar with what activities may have taken place at the school or child care facility and records are incomplete or absent, consider contacting individuals who may have been involved in the past. Personnel that were involved may remember activities that were not well documented. They may also remember whether other agencies or the local public water system were involved, which may mean that additional records are available.

Throughout this manual, recommendations are provided on when and how to set up a robust recordkeeping process for current and future efforts.



Communication Plan: Include your partners in your communication with the parents, staff, and the school or child care community. Also remember to communicate to partners as new information becomes available.

Module 1

Module 2

Module 3

Module 4

Module 5

Module 6

Module 7

Establishing Partnerships

Entities like the public water system, local health offices, state drinking water programs, certified laboratories, and local community organizations may be able to provide assistance in testing the drinking water for lead. The information below can be used to:

- Initiate communications with potential partners
- Identify ways these organizations could help the program
- Develop the right questions to ask each type of partner

In addition to contacting the public water system, schools and child care facilities may consider exploring partnership opportunities with private foundations, private businesses, and corporations, who may be able to provide funding, and local construction professionals, who may be able to provide technical expertise.

Assistance from Local Health Offices

Many local governments have established programs that are responsible for a wide variety of public health protection activities, such as Lead Poisoning Prevention Programs. Consider contacting the local health office to discuss particular needs or questions. Although resources may be limited, the health office may be able to provide assistance in a variety of ways. For example, a representative may be able to attend parent and teacher association (PTA) meetings to discuss potential health effects, as well as to act as a liaison with state programs to obtain information and assistance.

Assistance from the State Drinking Water, Health and Education Programs

Contact state program managers to determine whether training and/or technical assistance is available and whether any other requirements may apply. The state drinking water program may be housed in the department of health or the department of the environment. When discussing issues with the state program, consider requesting assistance and referring to the Lead Contamination Control Act (LCCA) or this 3Ts toolkit to help to clarify the request. A representative may even be able to assist in working through the plumbing profile, conducting sampling, or taking follow-up action.

Module 1

Module 2

Module 3

Many states have programs related to reducing lead in drinking water in schools and/or child care facilities. These programs may be in the state's environment, education and/or health departments. The state health and education departments may also be able to provide expertise and other information to support you in developing and maintaining their programs.

Module 4

The Association of State Drinking Water Administrators website contains links to many state drinking water programs: <https://www.asdwa.org/about-asdwa/>.

Module 5

Module 6

Module 7

Why Contact State Drinking Water Programs?

- For more information about lead in drinking water and drinking water regulations pertaining to lead.
- To inquire about training or available technical assistance on lead sampling.
- For advice in identifying a qualified consultant to assist with developing the 3Ts Program.
- For a list of certified laboratories in the area where samples can be analyzed for lead.

Assistance from Certified Laboratories

The state drinking water office should be able to provide a list of certified laboratories that you can use when testing for lead in drinking water. You should only use a laboratory that is certified by the state or EPA for testing lead in drinking water for public water systems.

Some laboratories will provide assistance in addressing the activities described in this manual. For example, some laboratories will collect samples for clients to ensure proper sampling technique and sample preservation. However, costs for services will vary and you may wish to contact several certified labs.

Assistance from Local Community Organizations

There are a variety of local organizations within communities that can help; for example, community volunteer groups, senior citizens' groups, the PTAs, and local environmental groups. Another useful resource is the region's pediatric environmental health specialty unit (PEHSU). The region's PEHSU may be able to provide risk communication support to districts; for more information, please visit <http://www.pehsu.net/>.

Contacting these groups is another way for you to foster support. These groups might be willing to volunteer time to collect samples and train others to collect samples. Local nonprofit and community-based organizations may also have monetary or in-kind resources available to support testing and/or remediation.

Working with Your Water System

A critical partner in any program to reduce lead in drinking water is the local water system. Before contacting community-based organizations and certified laboratories, EPA recommends contacting public water systems or local government offices for assistance. Water systems can help:

- Provide information that may be helpful
- Assist with determining if lead is present
- Support the you in developing your sampling plan
- Collect and analyze samples
- Help interpret results and determine potential lead sources
- Communicate with the school and child care facility, and the public

Module 1

Module 2

Module 3

Module 4

Module 5

Module 6

Module 7

View the 3Ts for Public Water Systems to see how they can help.

Lead and Copper Rule (LCR)	3Ts for Reducing Lead in Drinking Water
Required for: All community and non-transient non-community water systems.	Voluntary Program for: All schools with training, testing, and taking action.
Sampling Protocol: The LCR takes a system-wide approach. After 90th percentile lead level concentration of tap samples exceeds the 0.01 action level, water systems must take additional actions. This sampling protocol under the LCR requires a 1-gal first-draw sample after a stagnation period of 6 hours.	Sampling Protocol: Only schools and child-care facilities that are not part of a public water system must meet the requirements of the LCR. Under the 3Ts, EPA requires sampling and follow-up actions to be done at each individual facility. The 3Ts consists of a 2-step sampling protocol, which includes two 200-ml samples: (1) first draw after an 8- to 16-hour stagnation, and (2) a flush sample after 30 seconds.
Follow-Up Action: Water systems are required to undertake treatment actions, if necessary, such as point-of-use and point-of-entry treatment devices. They must also consider corrosion control, public education, water quality monitoring, and lead service line replacement.	Follow-Up Action: The 3Ts sample and the follow-up. Each facility will determine the location of the lead (i.e., the location behind the wall). This remediation measures can be implemented as appropriate to address the facility. This includes removing fixtures and replacing drinking water faucets, as necessary. (EPA 2018)

Notes: The recommended 2-step sample for the 3Ts because it is more effective at identifying the location of lead in the water system to determine a specific location of possible lead. (EPA) Sample flow a faucet would be less likely to occur in portions of the plumbing behind the wall that the faucet is connected to. There is no detectable level of lead for children. EPA encourages facilities to prioritize remediation efforts based on lead sample results and to use the steps in the 3Ts to prevent potential lead sources to reduce their lead levels to the lowest possible concentrations.

EPA **NCEM** **Office of Water**
EPA 815-B-18-002 October 2018

Contact the public water system to determine whether assistance or information on previous efforts is available. Some public water systems have devoted resources to helping you conduct testing for lead. Although utilities may not be under a legal obligation to do so, assistance may be available through technical guidance, sampling or sharing in sampling or laboratory costs. Some utilities may be willing to help develop sampling plans and plumbing profiles (see [Testing Section](#)).

Module 1

Module 2

Module 3

Module 4

Module 5

Module 6

Module 7

You can obtain the results of the water supplier's required monitoring under the Lead and Copper Rule to determine whether the supplier is in compliance with the requirements of the Rule. Public water systems should be able to tell you whether lead monitoring is current, whether the monitoring results are below the lead action level, and whether corrosion control treatment is provided. Your water supplier should also be able to tell you whether the supplier has conducted lead monitoring at the school or child care facility and may be able to provide some indication of whether lead could be a problem within your building(s).

In addition, EPA maintains a [data warehouse of drinking water information](#). Also, many states make comprehensive drinking water system data available in online databases. Data can be searched by state (i.e., primacy agency), city, and/or county to find public water system information. Some public water systems are required to produce and distribute an annual report about the public water system including system-wide monitoring results. These reports are often called consumer confidence reports or annual water quality reports. Contact your public water system to obtain a copy of the latest consumer confidence reports or water quality report or visit EPA's [Where You Live: Your Drinking Water Quality Reports Online](#) website to check if it is available online.



Module 1

Module 2

Module 3

Module 4

Module 5

Module 6

Module 7

Questions to Ask Drinking Water Systems

It is important to know who supplies your drinking water, and how the water is treated. The following are some questions to consider asking the public water system providing your drinking water:

- What information can the water system provide regarding its compliance with federal and state standards for lead monitoring and treatment?
- What steps have been taken to maintain compliance with the Lead and Copper Rule and reduce lead levels?
- Has the water system had a lead action level exceedance in its most recent compliance period?
- Does the water system have sample results for the school or child care facility?
- Does (or could) the water system take any LCR samples at schools or child care centers?
- Is the water corrosive? If so, what is the system doing to minimize corrosion?
- Does the water system add a corrosion control chemical to the water?
- Is there construction or water main maintenance planned in the area?
- Does the water distribution system have any lead piping (for example, lead service lines or lead gooseneck at service connections), and does the system plan to remove these sources of lead?

Don't forget to maintain a record!

Ensure that communications with partners are documented and kept in a centrally accessible repository, either online or at the facility. Documenting who you are working with and how partners are supporting the program will provide staff with additional points of contact if additional information is needed.



Assigning Roles

You should assign responsibility to a key individual(s) to ensure that testing and follow-up actions are completed. Identify individuals who will likely implement and document the 3Ts Program and who will build a new program at the school or child care facility. A person should also be appointed to serve as the contact person for communication with interested parties (civic groups, the media, etc.). One person or more may be involved in these activities, but it is important to clearly define responsibilities and to support those people in their roles. An effective 3Ts Program will require a team effort. Identifying specific roles and responsibilities before initiating a program will give the program accountability.

Module 1

Module 2

Module 3

Module 4

Module 5

Module 6

Module 7

Furthermore, by developing team dynamics that include internal communications, you can ensure that the program is successful and that staff turnover will not leave the program without direction or documentation. Whenever possible, get the school and child care administration involved. The superintendent, principal or school or child care facility director can give the 3Ts Program validity and support the individuals involved, improving the likelihood that their role in the 3Ts Program is integrated with their other job functions.

If you decide to use consultants or certified lab personnel, their roles should be defined and documented with respect to the responsible person(s) at your facility. Contact the state drinking water program or local health department if additional advice is needed on how to identify a qualified consultant.



Identify Key Individuals

The most important people to involve in the planning process for the school's 3Ts Program are those who will be required to approve, support or fund aspects of the program and those who have current job roles and responsibilities that align with protecting the health of the school or child care facility population. Key stakeholders both within and outside of the school and child care facility system include:

- **Principal/Director.** Include the superintendent if this is a multifacility initiative.
- **Custodial and facilities staff.** These individuals will have in-depth knowledge about plumbing and history and assist in implementing the program (e.g., take water samples).
- **School board.** Those responsible for developing budgets and recommending district-wide initiatives.
- **School nurse.** This individual will have knowledge of overall student health, as well as an awareness of the dangers of lead poisoning and the importance of safe drinking water. This individual may already work with the local health department, be able to identify local laboratories for testing samples and can also advise parents on how to get their children's blood lead levels tested.
- **Cafeteria staff.** These individuals are aware of water use in food preparation. They can identify the faucets that are regularly used in food or drink preparation, as well as any unused faucets.
- **Athletics staff.** These individuals will know the sources of water used to fill water jugs or those used when teams are practicing or playing games.
- **Students.** Should feel informed and educated on drinking water and know who to go to if they notice an issue.
- **Teachers.** Those affected by lead in drinking water and able to assist with the program. Teachers also might be sources of information on water use (e.g., knowing which fountains are most used). Math and science faculty will have knowledge of volume equations and water quality and could provide assistance during the testing process.
- **Parents.** Advocates for the children in schools and child care facilities.

Module 1

Module 2

Module 3

Module 4

Module 5

Module 6

Module 7

- **School district wellness committees.** Congressional legislation mandated that schools participating in the National School Lunch Program or other child nutrition programs create school wellness policies (USDA Team Nutrition).
- **Parent Teacher Associations (PTAs).** Student advocacy groups made up of parents and teachers.
- **Local plumbing and construction contractors/suppliers.** Those working on facilities; they should use “lead free” materials and plumbing products certified to be lead free.

Module 1

Module 2

Module 3

Module 4

Module 5

Module 6

Module 7

Programmatic Questions

Who should create the sampling plan?

It is important to designate a person(s) to serve as a project lead of the sampling program and follow-up activities, even if someone else is hired to conduct testing. You may want to involve consultants, laboratories, or other knowledgeable partners to help develop the plan. You can contact the state, local health department or drinking water program, or water system, to get advice on how to identify a qualified consultant.

Who should collect the samples?

Deciding who will collect samples may be based, in part, on whether the certified laboratory chosen to analyze samples also provides specialists to assist with sample collection. Choosing an individual who is adequately trained (e.g., a consultant or someone from the laboratory) to collect samples may help avoid sampling errors. Ask for references to confirm that individuals are qualified to test for lead in drinking water in schools and child care facilities. Some state drinking water programs or public water systems may provide both services, although there is no federal requirement that they do so.

Will the laboratory take samples or will it provide training and sample containers for collectors designated by the school or child care facility?

If certified laboratory representatives or consultants are used to conduct testing, ensure that they have experience in conducting lead testing for drinking water at schools and child care facilities. You may wish to ask the laboratory or consultant for references for work they have completed at other schools and child care facilities. Regardless of who is collecting samples, you should ensure the sampler is familiar with the procedures outlined in the [Testing Section](#). You should send the sampler a copy of this document, and any specific testing procedure documents, before sampling is

conducted. Testing activities can be misrepresentative if sample collectors do not follow proper sampling procedures. Also, make sure that laboratories or consultants do not confuse the sampling protocol with the lead testing protocol used by public water systems. The two protocols are different.

Who should ensure proper remediation?

If testing results show elevated levels of lead in drinking water, then you should implement remediation measures. Some State programs have additional requirements, such as notification and remediation, if testing results show lead in drinking water above specified levels. If remediation is needed, you should assign a project manager to lead the development of a remediation plan by a qualified professional and to ensure that remediation is properly completed. The [Taking Action Section](#), has more information on solutions that you can implement.

Who is in charge of recordkeeping?

Selecting a team member to ensure methods and results are documented is key to building a sustainable program that is not impacted by staff resignation, retirement, or transfer. The person responsible for recordkeeping should work with all other team members to gather information and store it in a centrally accessible place.

Module 1

Module 2

Module 3

Module 4

Module 5

Module 6

Module 7

Don't forget to maintain a record!

Document your 3Ts Program contacts and the steps your team will take to accomplish the goals set out in your 3Ts Program.

Use the [3Ts Toolkit](#) to identify and record contact information for partners from various organizations and groups described in this section.





Module 4: Developing a Sampling Plan

Module 1

Module 2

Module 3

Module 4

Module 5

Module 6

Module 7

This section includes recommended steps for developing and implementing a plan for testing drinking water in schools and child care facilities¹. Each section includes recommendations and explanations to help you understand your plumbing materials and sampling plan, evaluate your service connection (service lines), take samples, and interpret the results. The [Taking Action Section](#) provides short-term and longer-term control measures, examples of remedies for plumbing fixtures, and appropriate follow-up procedures that you should perform. **Throughout the testing process, remember to document the methodology, any implemented procedures or protocols, and testing results.**

Conduct a Walkthrough

Conduct a walkthrough of the facility and create an inventory. Take note of all sinks and fountains used for human consumption. If a floor plan is available, mark each tap and water filler on the floor plan and assign a unique identification. It may be helpful to take pictures when conducting this walkthrough. A plumbing profile can be created by answering a series of questions about the building's plumbing. The plumbing profile questionnaire in [Appendix G](#) can be used as a worksheet and recordkeeping tool. It may also be helpful to interview custodial staff and the teachers about water use.



Take note of the visible plumbing for these outlets. Staff creating the inventory may need to look under sinks or behind cabinets. Document whether faucets have aerators or filters in place to understand all possible sources of lead and any current remediation efforts at each fixture. Aerators should not be removed while conducting sampling for lead. If your facility has additions, wings or multiple buildings built during different years, a separate plumbing profile is recommended for each. Examples of plumbing configurations for a single-level building and a multilevel building are illustrated in Exhibit 2 and Exhibit 3, respectively.

Make sure to note any lead-lined storage tanks or lead parts such as those noted in [Appendix B](#). Water coolers identified by EPA as having lead-lined storage tanks or lead parts should be removed.

¹ For schools that are public water systems, there are regulatory requirements for sampling that must be followed to comply with the Lead and Copper Rule (LCR). The recommendations in this module could still be useful for those schools in addition to the monitoring required by the LCR.

Conducting this survey of the building's plumbing will enable you to:

- Understand how water enters and flows through building(s).
- Identify and prioritize samples.
- Identify additional sites staff or students may be using for drinking water, such as bathroom faucets, locker room showerheads, and non-traditional drinking water outlets that might be used to fill water jugs.

Module 1

Module 2

Module 3

Module 4

Module 5

Module 6

Module 7

Exhibit 2. Plumbing Configuration for a Single-Level Building

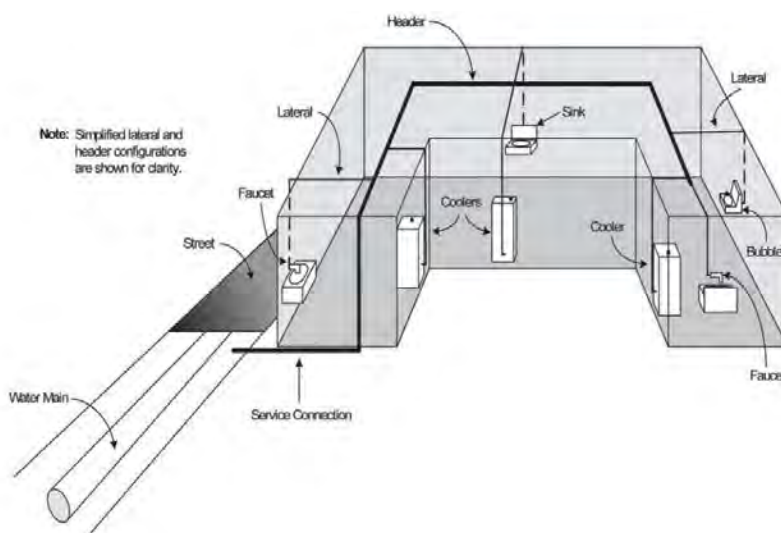

Header: The main pipe in the internal plumbing system of a building. The header supplies water to lateral pipes.

Lateral: A plumbing branch between a header or riser pipe and a fixture or group of fixtures. A lateral may or may not be looped. Where more than one fixture is served by a lateral, connecting pipes are provided between the fixtures and the lateral.

See [Appendix A](#) for additional definitions.

Exhibit 3. Plumbing Configuration for a Multilevel Building

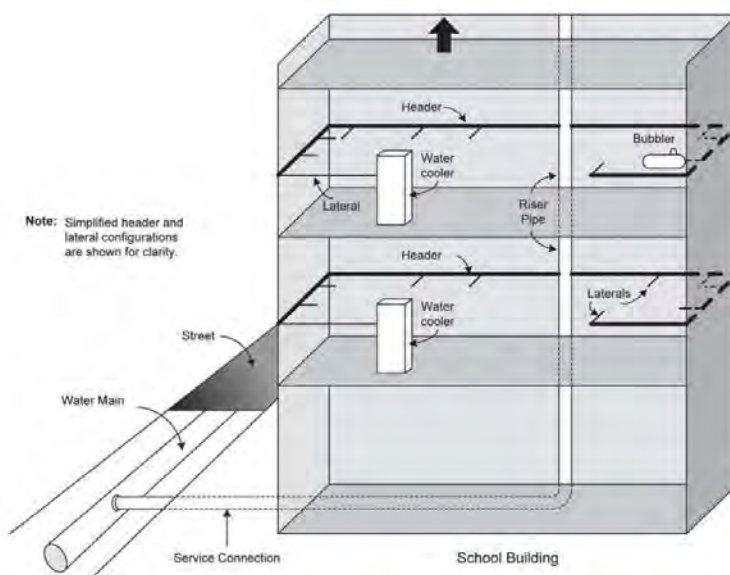

As shown in Exhibit 2, in single-story buildings, the water comes from the service connection via main plumbing branches, often called headers. These, in turn, supply water to laterals. Smaller plumbing connections from the laterals and loops supply water to the faucets, drinking water fountains and other outlets. In multilevel buildings (Exhibit 3), water is carried to the different floors by one or more riser pipes. In addition, in some buildings, water may be stored in a tank prior to being distributed to the drinking water outlets and fixtures. Remember, for sampling purposes, that water within a plumbing system moves from the water main in the street through the service connection and through the building. Sample collection should typically start on the bottom floor then continue up. However, the water main can enter the building from the first floor and splits to the riser running up to the second, third floors, etc., and the riser can lead to the basement. This configuration may also be different if the water tank is on the roof. Try to learn more about how water flows in your facility to better inform your sampling plan.

Module 1

Module 2

Module 3

Module 4

Module 5

Module 6

Module 7

Determine Sampling Locations

Decide where to take samples and how to prioritize the sample sites based on responses to the plumbing profile questionnaire and knowledge of the building(s). This should include drinking fountains, kitchen sinks, kitchen kettle filler outlets, classroom combination sinks and drinking fountains, home economics room sinks, teachers' lounge sinks, nurse's office sinks, and any other sink known to be or visibly used for consumption (e.g., coffeemaker or cups are nearby). Faucets that are not used for human consumption, such as sinks in janitor's closets or outdoor hoses, should not be sampled. If there is potential that these may be used (e.g., janitor closet is close to kitchen and is used for cleaning appliances or the outdoor hoses are used to fill water jugs for sports activities), use clear signage to notify people that the faucet should not be used for drinking or cooking, or include the fixture in your sampling plan.

Helpful Tip...

Don't forget to include kitchen kettles in your sampling plan. Kitchen kettles are large containers of water that are then heated to steam or cook things like vegetables, sauces, pastas, rice, etc. They are used in larger kitchens, like some school kitchens, and sample results taken from these have found to contain elevated lead.

Important: schools and child care facilities should not use sample results from one outlet to characterize potential lead exposure from all other outlets in their facility. This approach could miss localized lead problems that would not be identified.

Make sure to prioritize outlets that are used by children under the age of 6 years or pregnant women (e.g., drinking fountains, nurses' office sinks, classrooms used for early childhood education, kitchen sinks, teachers' lounges).

During the process of determining sample locations, it will be helpful to code each outlet using a system that will allow each unique outlet to be identified by location, type and other relevant characteristics. [Appendix C](#) provides examples.

Module 1

Module 2

Module 3

Module 4

Module 5

Module 6

Module 7

Do You Have a Lead Service Line?

Lead pipes were used for service connections, or service lines, in some locations. Other materials used for service lines include copper, galvanized steel, plastic, and iron. In larger schools, the service line is probably not lead because lead is impractical for the larger service lines typically used in these facilities; however, many child care facilities reside in small buildings and are at a higher likelihood of being served by lead lines.

Regardless of building size, make sure to check the service line. The water system may be able to provide information about whether there is a lead service line or can help identify the service line for your facility.

Lead service lines may be visible and are generally a dull gray color and very soft. They can be identified easily by carefully scratching with a key. If the pipe is made of lead, the scratched area will turn a bright silver color. Do not use a knife or other sharp instruments and take care not to puncture the pipe.

Picture of a Scratch on a Lead Service Line



Selecting a Laboratory for Sample Analysis

Regardless of who collects the samples, you should employ a certified laboratory approved by the state or EPA for testing lead in drinking water. Contact the state drinking water program or the public water system, or visit EPA's website: [Contact Information for Certification Programs and Certified Laboratories for Drinking Water](#) for a list of certified laboratories in the area. Consider the following issues prior to making a selection:

Considerations When Choosing a Laboratory

- Will the laboratory conduct sampling as well as analyses? Be sure to let the laboratory know that samples will most likely be taken between 5:30 a.m. and 7:30 a.m. Sampling outside of business hours may influence the cost.
- What is the cost of the laboratory's services, and what is included in that cost? Costs will vary, depending upon the extent of the services to be provided (e.g., if only analyses are conducted or if other services such as sample collection are provided), and some laboratories may have bulk analysis rates for a large number of samples.
- You may want to contact several laboratories to compare prices and services, and they may wish to combine sampling with another school or child care facility to reduce the cost per sample.
- What other testing could the laboratory conduct for your facility? See [Appendix D](#) for more information.
- What is the laboratory's time frame for providing sample results?
- Establish a written agreement or contract with the laboratory for all of the services to be provided.

Module 1

Module 2

Module 3

Module 4

Module 5

Module 6

Module 7

Determine Your Sampling Frequency

How frequently your facility can and should test for lead in drinking water is dependent on a variety of factors (e.g., plumbing, water quality, lead results, budget, and competing priorities). Regardless of the frequency set by your facility, EPA recommends that the sampling frequency be documented so that it does not go overlooked for extended periods of time.

EPA suggests schools and child care facilities make testing drinking water a part of their regular building operations. Annual monitoring provides information on changes in the lead levels and the effectiveness of remediation or treatment efforts as well timely notice of lead levels that need to be addressed.



Communication Plan: Before you begin sampling, it is important to engage with the community and develop a plan for how to communicate throughout the sampling process.

Understanding the Sampling Procedures

Who should collect 3Ts Samples?

It is important that water samples be collected properly. Certified laboratories chosen to analyze samples may provide specialists to assist with sample collection. If the laboratory is not supplying someone to sample, be sure to identify an individual who is adequately trained to collect lead samples to help avoid sampling errors. It is useful to ask for references to confirm that individuals are qualified to test for lead in schools and child care facilities. Some state drinking water programs or public water systems may provide both services, although there is no federal requirement that they do so.

Module 1

Module 2

Module 3

Module 4

Module 5

Module 6

Module 7

What is the recommended sample volume?

EPA recommends the use of small samples (e.g., 250-mL) because a smaller sample represents a smaller section of plumbing, which can help you to identify the sources of lead at an outlet (e.g., fixture, interior plumbing, or water entering the school). A smaller sample is also more representative of the amount of water consumed per serving.



What are the recommended types of samples?

First-draw samples

First-draw samples are typically collected in the morning at outlets that are used for drinking or cooking, after the water has been sitting still the night before. Begin collecting the sample immediately after turning on the faucet or valve, not allowing any water to spill. EPA strongly recommends that schools collect first-draw samples from all fixtures used for consumption and prioritize sampling from high-risk fixtures.

Module 1

Module 2

Module 3

Module 4

Module 5

Module 6

Module 7

Flush samples

Flush samples are taken after water has been running from the fixture for a pre-determined length of time. These types of samples are used in Step 2 (described in the [2-Step Sampling Section](#) of the 3Ts). Flush samples can be used to determine if lead is coming from the fixture itself or from interior plumbing.

Sequential samples

Sequential samples involve collecting a series of water samples at a single fixture, without flushing beforehand or running the water between samples. This sampling procedure is another method used in a Detailed Fixture Evaluation described in [Appendix D](#), to sample multiple sections of plumbing.

When should samples be collected?

Collect all water samples *before* the facility opens and *before* any water is used. Ideally, the water should sit in the pipes unused for at least 8 hours but not more than 18 hours before a sample is taken. However, water may be more than 18 hours old at some outlets that are infrequently used. If this is typical of normal use patterns, then these outlets should still be sampled. Make sure that no water is withdrawn from the outlets prior to their sampling. Remember not to use the facilities' restrooms or sinks that morning prior to sampling.

Unless specifically directed to do so, do not collect samples in the morning after vacations, weekends or holidays because the water will have remained stagnant for too long and will not represent the water used for drinking during most of the days of the week. See [Establishing Routine Practices](#) to learn ways to improve water quality throughout the year and after long breaks.

When should I take action?

There is no safe level of lead for children. EPA encourages schools to prioritize remediation efforts based on lead sample results and to use the steps in the toolkit to pinpoint potential lead sources to reduce their lead levels to the lowest possible concentrations.

Module 1

Module 2

Module 3

Module 4

Module 5

Module 6

Module 7

Before sampling, facilities should establish a plan on how they will respond to their sample results to protect the school and child care facility population from lead in drinking water. This may be dependent on a variety of factors (e.g., age of plumbing, population, water corrosivity, available resources, and other school and child care program priorities). EPA recommends that you prioritize remediation of drinking water outlets with the highest lead levels.

Make sure to also check with your state and local health department. They may have guidance or even requirements that include a lead remediation trigger.

Note: EPA's Lead and Copper Rule (LCR) establishes a lead action level of 15 parts per billion (ppb) for water systems and facilities that have and/or operate their water source (e.g., own their own well). If the 90th percentile lead level concentration of tap samples exceeds the 15 ppb action level, water systems must take additional actions, such as optimizing corrosion control, public education, and lead service line replacement. The action level for lead is not a health-based standard and is based upon EPA's evaluation of available data on the ability of corrosion control to reduce lead levels at the tap. The action level is a screening tool for determining when certain treatment technique actions are needed.

Module 5: Conducting Sampling and Interpreting Results



Communication Plan: Don't forget to communicate your plans to test your facility, and to prepare for communicating results. Results should be shared regardless of the lead level detected.

Module 1

Module 2

Module 3

Module 4

Module 5

Module 6

Module 7

2-Step Sampling at the Tap

EPA recommends that schools and child care facilities conduct a 2-step sampling procedure to identify if there is lead in the outlet (e.g., faucet, fixture, or water fountain) or behind the wall (e.g., in the interior plumbing). These samples should be taken after an 8 to 18-hour stagnation period.

Please note that this section contains recommendations that are generalized for typical plumbing configurations. [Appendix D](#) contains details on types of fixtures and targeted sampling.

STEP 1

250-mL First-Draw Sample

Take a 250-mL first-draw sample at all taps used for consumption to identify potential lead in the fixture.

STEP 2

250-mL Flush Sample

If the result of Step 1 is high, take a 30-second flush sample to identify lead in the plumbing behind the fixture.

These samples can be taken in the same sampling event, which can reduce cost, and provide you with more information on lead levels. If not taking these samples at the same time, and elevated lead levels have been found in Step 1, the water should not be consumed while preparing to take the follow-up flush sample. More information on immediate steps is in the [Taking Action Section](#).

Helpful Tip...

For further potential cost savings, you or lab can collect, preserve, and hold (but not analyze) the second sample at the same time the first sample is collected, then analyze only selected Step 2 samples based on review of the Step 1 results. Most commercial labs will "Hold" samples until the client advises to dispose (at nominal cost) or analyze those samples.



Step 1: Initial First-Draw Samples

Take first-draw samples from fixtures throughout the building that are used for human consumption. EPA strongly recommends that you collect these samples from all outlets used for drinking or cooking, prioritizing the high-risk outlets (i.e., fixtures that are known to or potentially contain lead and fixtures that are used most frequently). The plumbing profile will help pinpoint those high-risk fixtures and to prioritize sample collection.

Important: schools and child care facilities should not use sample results from one outlet to characterize potential lead exposure from all other outlets in their facility. This approach could miss localized lead problems that would not be identified.

The first-draw sample identified in Step 1 is representative of the water that may be consumed at the beginning of the day or after infrequent use. This protocol maximizes the likelihood that the highest concentrations of lead will be found because the first 250-mL sample is collected after overnight stagnation (the water sat in the pipes for at least 8 hours).



Procedures for initial outlet samples are shown below:

- All samples should be collected before the facility opens and before the fixtures have been used (EPA recommends an 8-18 hour stagnation period).
- One 250-mL sample should be taken at each fixture. Note this is a first-draw sample. Therefore, collect the sample immediately after opening the faucet or valve.
- Compare all sample results to prioritize follow-up sampling and remediation. Outlets with elevated lead levels should not be made available for consumption.

STEP 1

250-mL First-Draw Sample

Take a 250-mL first-draw sample at all taps used for consumption to identify potential lead in the fixture.

Module 1

Module 2

Module 3

Module 4

Module 5

Module 6

Module 7

High Results Due to Particulate Lead

If initial first-draw sampling results reveal high lead levels in the 250-mL sample for a given outlet, a contributing source of the elevated lead levels could be the debris in the aerator or screen of the outlet. By cleaning the aerator or screen and retesting the water following the initial first-draw sampling procedures, you can identify whether or not the debris is contributing to elevated lead levels.

Determining aerator/screen debris contribution:

Scenario 1: The initial sample result is 19 ppb; you decide to see if the aerator is contributing to lead in the water. After cleaning out the aerator, you take another first-draw sample. The results come back less than or close to the detection level (e.g., 1ppb). This result indicates that the debris in the aerator was likely contributing to elevated levels in the fixture. Continue to clean the aerator on a regular basis; continued use of the outlet should be acceptable. However, please note that without regular maintenance, this outlet may serve water with elevated lead levels.

Scenario 2: The initial sample result is 22 ppb; you decide to see if the aerator is contributing to lead in the water. After cleaning out the aerator, you take another first-draw sample. The second sample result is very close or equivalent to the 22 ppb sample. Since the initial sample and post-cleaning first-draw sample results are similar, the problem is likely not the aerator.

Scenario 3: The initial first-draw sample result is 60 ppb; you decide to see if the aerator is contributing to lead in the water. After cleaning the aerator, you take another first-draw sample. The post-cleaning sample result is 25 ppb. Although the results are lower, they are still high; this indicates that the aerator is likely a contributing source and that the outlet itself and/or the plumbing upstream of the aerator are contributing as well. If this situation occurs, the school should take this fixture offline, and continue with 2-step sampling, or consider the Detailed Fixture Evaluation in [Appendix D](#) to target the additional contributing sources.

* When taking a second first-draw sample, please remember to follow the same sampling procedure as the initial first-draw sample. Ensure that fixtures and outlets have been out of use for 8-18 hours, sampling before students arrive at the facility.



Picture of an aerator with particulate

Module 1

Module 2

Module 3

Module 4

Module 5

Module 6

Module 7



Step 2: Follow-Up Flush Samples

If initial test results reveal elevated lead, follow-up flush testing described in Step 2 is recommended to determine if the lead contamination results are from the fixture or from interior plumbing components. Follow-up flush samples generally involve the collection of water from an outlet where the water has run for 30 seconds.

The purpose of Step 2 is to pinpoint where lead is getting into drinking water (i.e., fixtures versus interior plumbing) so that appropriate corrective measures can be taken.

Procedures for initial outlet samples are shown below:

- As with initial first-draw samples, follow-up flush samples are to be taken before a facility opens and before any water is used. For best results, flush samples from different outlets that are in close proximity should be collected on different days. For drinking fountains or other fixtures that are manifolded closely together, a single flush sample may be representative of the shared interior plumbing.
- The sampler should be careful to maintain a consistent rate of flow when collecting flush samples.
- Open up the tap and let the water run for 30 seconds. Then, take a 250mL sample. Make sure to label this sample bottle as the flush sample.

STEP 2

250-mL Flush Sample

If the result of Step 1 is high, take a 30-second flush sample to identify lead in the plumbing behind the fixture.

Module 1

Module 2

Module 3

Module 4

Module 5

Module 6

Module 7

Sampling Dos and Don'ts

Module 1

Module 2

Module 3

Module 4

Module 5

Module 6

Module 7

Do:

- Follow the instructions provided by the laboratory for handling sample containers to ensure accurate results.
- Assign a unique sample identification number to each sample collected. Use a coding scheme to help differentiate samples, and don't forget to label each sample bottle.
- Collect all water samples before the facility opens and before any water is used. The water should sit in the pipes unused for at least 8 hours but not more than 18 hours before a sample is taken.
- Learn how water flows in your facility. If there are multiple floors, it is typically recommended to sample from the bottom floor and continue up. Start sampling closest to the main and work away.

Don't:

- Remove aerators prior to sampling. Potential sources of lead may be missed if aerators are removed, since debris could be contributing to the lead in drinking water if particles containing lead are trapped behind aerator screens.
- Flush water prior to sampling, unless instructed to do so. Flushing can be a tool to improve water quality, especially after long holidays or weekends. However, flushing prior to sampling may cause results showing lower-than-representative lead levels in the water. See [Flushing Best Practices Factsheet](#) for more information.
- Close the shut-off valves to prevent their use prior to sample collection. Minute amounts of scrapings from the valves can produce results showing higher-than-representative lead levels in the water.

Don't forget to maintain a record!

Recording sample information is critical to tracking and managing water quality year-over-year. Record sampling procedures, locations, and results.

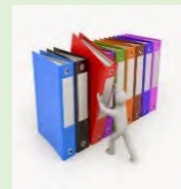



Module 6: Remediation and Establishing Routine Practices

Module 1

Module 2

Module 3

Module 4

Module 5

Module 6

Module 7

Solutions to lead problems typically should be addressed on both a short-term and a long-term basis. Measures can be taken while you wait for your test results or until a permanent solution has been put in place. It is helpful to become familiar with potential remediation options before sampling has occurred. You should work closely with maintenance staff and plumbers who may make repairs to ensure that the chosen remediation options will remove lead from the water and to understand the benefits and considerations associated with each option. It is also important to ensure that your school and/or child care facility population are familiar with the use of new fixtures or technology that may be installed.

When selecting a remediation provider, engage the local health department, public water system, and other available resources to ensure the organization performing remediation is qualified and reputable. Ask vendors for information on the schedule, health precautions that must be taken during and following remediation and request regular status updates on their progress prior to agreeing to work with any particular organization. The internal team should identify an individual that is responsible for working with the remediation contractors. This person should regularly communicate the schedule, activities, and hazards to the 3Ts Program team.

Immediate Response

Below are some immediate actions to consider following the receipt of results indicating elevated lead in drinking water.

Shut Off Problem Outlets

If initial sample results from an outlet exceed the remediation level, the outlet can be shut off or disconnected until the problem is resolved. Shutting off problem outlets can also provide a permanent solution. If the outlet is not used regularly, this may be a viable option; however, if the outlet is frequently used, this is probably not a practical long-term solution.



Share Test Results

Post test results in your facility (i.e., in the administrative offices), and on a public website. Notify staff, parents, and students of test results and actions you are taking. Also, reach out to the public water system to share results and discuss potential remediation measures.

Post “Not for Drinking/Cooking” at Problem Outlets

If initial sample results from an outlet exceed the remediation trigger level, but the problem outlet is routinely used for purposes other than human ingestion (e.g., hand-washing), clear signage can be posted to notify people that the outlet is not to be used for drinking or cooking until the problem is resolved.

Increase Awareness and Public Education



Take the initiative in providing information to your community. Be a good and reliable source of information on your program for reducing lead in drinking water. Be positive, proactive, and forthcoming when working with the media, members of the community, parents, students, and staff.

Short-Term Control Measures

Below are short-term measures facilities can take as they consider long-term or permanent control measures. You should consider the pros and cons of each before choosing what steps are most appropriate. As you implement short-term measures, you should also consider the benefit of remediation that removes the risk of lead contamination (noted in the [Permanent Control Measures Section](#)).

Provide Filters at Problem Taps

Point-of-use (POU) units are commercially available and can be effective in removing lead. There are a number of POU cartridge filter units on the market that effectively remove lead. They can be relatively inexpensive (\$65 to \$250) or more expensive (\$250 to \$500), their effectiveness varies, and they may be vulnerable to vandalism. Filters need routine maintenance (e.g., cartridge filter units need to be replaced periodically) to remain effective.

Module 1

Module 2

Module 3

Module 4

Module 5

Module 6

Module 7

To select a lead-reducing POU filter, check with the manufacturer or a third-party website (such as nsf.org or wqa.org) to verify the product was tested and certified against NSF/ANSI Standard 53 (for lead removal). For additional protection for particulate lead, look for a POU filter that is also certified against NSF/ANSI Standard 42 (for class I particulate reduction, 0.5 µm to <1 µm).

Module 1

Module 2

Module 3

Module 4

Module 5

Module 6

Module 7

POE vs POU: Point-of-entry (POE) and POU devices are different types of treatment options. A POU is installed at each outlet, while a POE is installed where the water enters the building. If you are considering installing a device to treat water entering their buildings, you should first consult with your state drinking water office. Installation of a POE device could lead to your facility being identified as a public water system under SDWA, and your facility could be required to meet the federal and state regulations for drinking water, including additional water quality monitoring. In addition, POE devices are not effective in remove lead that comes from plumbing materials within the school or child care facility.

Flush Taps Prior to Use

Flushing individual problem water outlets or all outlets within the school or child care facility may also represent a short-term solution. However, unless you can ensure lead levels remain low throughout the day, flushing just once a day or once a week is not recommended. If follow-up flush samples indicated no or low lead levels, facilities could use signage that notifies staff and students to flush for 30 seconds prior to each use. It is important to create schedules and ensure implementation of these practices until permanent control measures have been completed. See the [Flushing Best Practices](#) factsheet for additional information on outlet flushing instructions.

Provide Bottled Water

This can be an expensive alternative but might be warranted if you are aware of widespread contamination and other remediation is not a near-term option. If you use bottled water, be aware that it is not regulated by EPA but rather by the Food and Drug Administration (FDA). States may also regulate bottled water, and in some instances, these standards may be more stringent than the federal requirements. EPA recommends that you request a written statement from the bottled water distributor guaranteeing that the bottled water meets FDA and state standards. A copy of this letter should be recorded.

Permanent Control Measures

You can take a number of actions to permanently reduce or eliminate the sources of lead that originate in building plumbing. After obtaining an understanding of the water supply and the lead conditions in their facilities through testing, you should examine the permanent remediation options and select those most appropriate to their situation. The decision will be based on such factors as cost, likelihood of success, availability of water, and staffing requirements.

Module 1

Module 2

Module 3

Module 4

Module 5

Module 6

Module 7

Replacement of Problem Outlets

After identifying the sources of lead contamination, replacing these identified outlets and any identified upstream plumbing components (e.g., valves, leaded solder) permanently address the problem, compared with other solutions that have long-term costs and risks. If the sources of lead contamination are localized and limited to a few outlets, replacement may also be the most cost-effective option in the short-term. EPA's revised March 2015 guidance, [How to Identify Lead-Free Certification Marks for Drinking Water System & Plumbing Products](#), can be a useful resource selecting lead-free plumbing. Follow-up testing is also recommended, as with the other remedies, to ensure that the efforts result in reduced lead levels at the fixture outlets.

Helpful Tip...

If multiple replacements of one type of component (for example, fountain valves) are needed, you may wish to purchase only one or two initially. Take follow-up water samples after installing the new component(s) to verify that lead levels are reduced to acceptable levels. If follow-up testing is satisfactory, you can be reasonably certain that the product would perform well at other locations in your facilities.

Pipe Replacement

Lead pipes within your property and portions of a lead service lines under your and/or public water system's jurisdiction can be replaced. Contact the public water system regarding jurisdiction. you may be responsible for replacing the portion of a lead service line that is on school or childcare property, rather than under the jurisdiction of the public water system.

Provide Filters at Problem Taps

Some facilities may also choose to use certified lead-reducing filters, also called Point of use (POU) units as a long-term or permanent control measure. When doing this, facilities should be sure to create maintenance schedules and identify a point of contact to be in charge of making sure they are properly maintained.

Reconfigure Plumbing

Ongoing renovation of school or childcare buildings may provide an opportunity to modify the plumbing system to redirect water supplied for drinking or cooking to bypass sources of lead contamination. Before undertaking such an alternative, be certain that you have properly identified all of the sources of lead contamination in drinking water. Follow-up testing is also necessary, to ensure that the efforts result in reduced lead levels at the drinking water outlets.

Helpful Tip...

Flushing can be a tool after remediation. In addition to replacing or removing lead containing plumbing or fixtures flushing can help clear out debris or lead particulates that may be released when remediation occurs.

Module 1

Module 2

Module 3

Module 4

Module 5

Module 6

Module 7



Follow-Up Sampling

Once a remediation option has been selected and implemented, there are additional follow-up procedures that should be taken. Work with plumbers and maintenance staff to ensure that additional samples are taken from any outlets that were impacted by replacement of fixtures, reconfiguration of plumbing, or other remediation actions.

Ensure that additional samples are taken before a facility opens and before any water is used. Additional samples should follow the same testing process as the initial samples. Sample any replaced or reconfigured components using the recommended procedures for first-draw and/or flush samples. Be sure to document (e.g., in sample labeling) the conditions that follow-up samples were collected, such as after fixture replacement or after POU installation.

A comparison of original and additional samples will help to assess whether the remediation has been successful in reducing lead in drinking water. Additional samples may be required to further pinpoint sources of lead contamination, if lead levels are still elevated.

Follow-up sampling when flushing is being used

If flushing is selected as a remedy, follow-up testing procedures should include sampling to verify the effectiveness of flushing procedures at each problem outlet. If the 30-second flush sample (in Step 2) is low, flushing for 30 seconds may be sufficient.

In other cases, a longer flushing duration may need to be determined. See the [Flushing Best Practices](#) factsheet for additional information on outlet flushing instructions.

After determining the required flushing duration, repeat sampling should be collected after flushing, followed by a period of normal water use at the fixture, to determine whether flushing daily, twice daily, or at a different frequency is needed to ensure lead levels remain low throughout each day. For determining if once-daily flushing is sufficient, flush the outlet at the routine time and duration (e.g., 30 seconds) and then collect one 250-mL sample near the end of the day (e.g., after 10 hours of representative water usage following morning flushing). If the sample collected at the end of the day contains high levels of lead, more frequent flushing (e.g., every 4 hours or every time the outlet is used) or a different remedy should be evaluated.

Module 1

Module 2

Module 3

Module 4

Module 5

Module 6

Module 7

Considerations for Replacement Activities

When making any repairs, ensure that “lead-free” materials are used. Make sure that any plumber who does repair or replacement work on the facility’s plumbing system uses only “lead-free” solders and other materials. The 1986 Safe Drinking Water Act Amendments and the 2011 Reduction of Lead in Drinking Water Act require that only “lead-free” materials be used in new plumbing and plumbing repairs. Make sure all plumbers and other workers adhere to these requirements. These actions will prevent or minimize new lead from being introduced into the facility’s plumbing system. Report any violations of the “lead-free” requirements to the local plumbing inspector, the state drinking water program or EPA.

Electrical current may accelerate the corrosion of lead in piping materials, so also consider checking grounding wires. Existing wires already grounded to the water pipes can in some cases be removed by a qualified electrician and replaced by an alternative grounding system. If local or state building codes allow, consider finding an alternative grounding system and having a qualified electrician make the change. Be aware that the removal of grounding from water pipes may create a shock hazard unless an acceptable, alternative ground is provided.



Communication Plan: Share your plans to remediate if elevated lead is found. This may include short-term or permanent measures.

Don't forget to maintain a record!

Record remediation efforts, schedules for upkeep and maintenance, and partners and contacts that assisted in your efforts.



Establishing Routine Practices

Schools and child care facilities should establish routine practices to reduce exposure to elevated lead levels and other environmental hazards (e.g., bacteria). **These activities should not be conducted immediately prior to collecting a water sample but should be planned as part of the school's or child care facility's overall water management program to improve drinking water quality.** Below are examples of routine activities that should be conducted to prevent exposure to drinking water contaminants:

Module 1

Module 2

Module 3

Module 4

Module 5

Module 6

Module 7

Cleaning

- Clean drinking water fountains regularly. Consider posting a cleaning time card by the water fountains to allow the cleaning times to be recorded.
- Create an aerator (faucet screen) and water fountain strainer cleaning maintenance schedule and clean debris from all accessible aerators and strainers frequently. Establish a recordkeeping procedure to record when the aerators and strainers are cleaned.
- Consider setting a reminder on the calendar to notify the maintenance staff when it is time to clean the aerators and water fountain strainers.

Temperature Control

- Use only cold water for food and beverage preparation. Hot water will dissolve lead more quickly than cold water and may contain increased lead levels.
- If hot water is needed, it should be taken from the cold water faucet and heated on a stove or in a microwave oven. Consider creating notices that can be posted in the food and beverage preparation areas to remind students and staff to use cold water.

Point-of-Use Filter Maintenance

- If POU devices have been installed, make sure they are maintained. An example of a POU device is a filter on a faucet or within a drinking water fountain or water bottle filler.
- Ensure that the selected POU device is certified to remove lead (or any other contaminants of concern). To select a lead-reducing POU filter, check with the manufacturer or a third-party website (such as nsf.org or wqa.org) to verify the product was tested and certified against NSF/ANSI Standard 53 (for lead removal). For additional protection for particulate lead, look for a POU filter

that is also certified against NSF/ANSI Standard 42 (for class I particulate reduction, 0.5 µm to <1 µm).

- Consider setting a reminder on the calendar when it is time to change the filter.

Cross-Connections Control

- Evaluate the facility for the presence of cross-connections (e.g., connections of nonpotable water to potable sources) and address any issues.

Communication

- Create and post placards near bathroom sinks with notices that water should not be consumed. As an example, indicate that a sink is a hand-washing only sink to prevent students and staff from misunderstanding and utilizing sinks for brushing teeth, washing food or other activities that ultimately result in water being consumed.
- Use pictures if there are small children using bathrooms.
- Consider organizing an event for the community to explain how everyone can help.

Routine Flushing Practices

- Regularly flush all water outlets used for drinking or food preparation, particularly after weekends and long vacations when water may have been stagnant for a long period of time.
- Flushing involves opening valves and faucets and letting the water run to remove water that has been standing in the interior pipes and/or the outlets. The flushing time varies by the type of outlet being cleared.
- Be careful not to flush too many outlets at once. This could dislodge sediments that might create further lead problems, or it could reduce pressure in the system below safe levels. If the flow from outlets is reduced noticeably during flushing, too many outlets have likely been turned on at once.



Module 1

Module 2

Module 3

Module 4

Module 5

Module 6

Module 7

Flushing Directions by Outlet Type

Remember that each drinking water outlet should be flushed individually; flushing a toilet will not flush the water fountains. All flushing should be recorded in a log submitted to the individual in charge of this program.

Locate the faucet furthest away from the service line on each wing and floor of the building, open the faucets wide, and let the water run for 10 minutes. For best results, calculate the volume of the plumbing and the flow rate at the tap and adjust the flushing time accordingly. This 10-minute time-frame is considered adequate for most buildings.

Open valves at all drinking water fountains without refrigeration units and let the water run for roughly 30 seconds to one minute, or until cold.

Let the water run on all refrigerated water fountains for 15 minutes. Because of the long time period required, routinely flushing refrigerated fountains may not be feasible. It may therefore be necessary, and more economical, to replace these outlets with “lead-free” NSF-approved devices.

Open all kitchen faucets (and other faucets where water will be used for drinking and/or cooking) and let the water run for 30 seconds to one minute, or until cold.

Flushing is not recommended as a practical remedy for water coolers.

Module 1

Module 2

Module 3

Module 4

Module 5

Module 6

Module 7



Communication Plan: Your continual effort to improve water quality in your facility will be of interest to parents, staff, and the community. Consider sending updates in newsletters.

Don't forget to maintain a record!

Record schedules for upkeep and maintenance and set calendar reminders to help you keep on schedule.

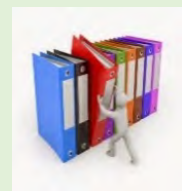



Module 7: Recordkeeping

Keep Records

Finally, it is important to keep an ongoing record of partners, team contacts, testing efforts, remediation efforts, public outreach, and communication activities. Keep copies of past communication materials and dates they were sent out. It is imperative to be able to prove steps were taken to inform the public on lead issues. Strong recordkeeping can also prove to be helpful in illustrating what steps you have taken to notify the public of testing efforts and results.

Furthermore, recordkeeping is important for the “Taking Action” portion of the program—by documenting their outreach and the public’s response, you can learn how to improve upon their public communication plan. For example, it might be helpful to keep a running log of questions received from the community that could be addressed in future communications. As mentioned previously, you could create a separate email address for the lead program so that questions are sent to a single point of contact.

[See the 3Ts Toolkit for recordkeeping templates and customizable forms.](#)



Module 1

Module 2

Module 3

Module 4

Module 5

Module 6

Module 7

Appendix A: Glossary of Terms

Aerator: Also called a “screen” is typically located on the fixture valve (e.g., where the water comes out) to improve water flow out of a tap or drinking water fountain. These aerators can collect sediment and lead particulate and should be cleaned regularly. See the [Establishing Routine Practices Section](#) for more detail.

Chiller: A central refrigeration unit providing cold water to some types of drinking water fountains.

Corrosion: A dissolving and wearing away of metal caused by a chemical reaction (e.g., between water and the piping that the water contacts).

Cross-connection: A cross-connection is a point in a plumbing system where it is possible for a nonpotable substance to come into contact with the potable drinking water supply.

Detailed Fixture Evaluation: A sampling process designed to pinpoint where (i.e., fixtures or interior plumbing) lead is getting into drinking water so that appropriate corrective measures can be taken.

Drinking Water Fountain: A fixture connected to the water supply that provides water as needed. There are different types of drinking water fountains: fountains without central chillers, fountains with central chillers, water coolers, bottled water fillers, etc.

Faucet: A valved outlet device attached to a pipe that normally serves a sink or tub fixture. A faucet discharges hot and/or cold water for a variety of consumptive uses, including drinking, cooking, and washing. The term “faucet” is used interchangeably with the term “tap.”

First-Draw Samples: These are the samples taken immediately after turning on the faucet or valve, without spilling, if possible. These samples represent the lead content of water sitting in water outlets that are used for drinking or cooking within the building(s).

Fittings: These are generally static parts that are used to join sections of pipe, or to join pipe to outlet fixtures.

Flush Samples: These samples are taken after water has been running from the fixture for some pre-determined length of time. They can be used to determine if lead is coming from the fixture itself or from interior plumbing.

Flux: A substance applied during soldering to facilitate the flow of solder. Flux often contains lead and can itself be a source of lead contamination in water. The “lead-free” requirements of the 1986 Safe Drinking Water Act Amendments require that solders and flux not contain more than 0.2 percent lead.

Fountain Valve: The valve and discharge device that mounts on top of the bubbler fixture and discharges water for consumption. This document does not distinguish bubbler drinking water fountains from other types of fountains. Therefore, the term “fountain valve” is used interchangeably with bubbler valve.

Header: The main pipe in the internal plumbing system of a building (*see Interior Plumbing definition below for context within this document*). The header supplies water to lateral pipes.

Inlet: A location where the water enters a plumbing component, such as where the water from the pipes enters a central chiller (defined above).

Interior Plumbing: For the sake of this document, interior plumbing is the plumbing within the wall and upstream of the fixture.

Lateral: A plumbing branch between a header or riser pipe and a fixture or group of fixtures. A lateral may or may not be looped. Where more than one fixture is served by a lateral, connecting pipes are provided between the fixtures and the lateral.

Lead-free: Per the Reduction in Lead Drinking Water Act of 2011: not containing more than 0.2 percent lead when used with respect to solder and flux; and not more than a weighted average of 0.25 percent lead when used with respect to the wetted surfaces of pipes, pipe fittings, plumbing fittings, and fixtures.

Outlet: A location where water may be accessed for consumption, such as a drinking fountain, water faucet or tap.

Potable Water Pipe: The pipe in a distribution system and in a building which carries water intended for human consumption.

Public Water System: Any system for the provision of water for human consumption through pipes or other constructed conveyances if the system has 15 or more service connections, or regularly serves an average of at least 25 persons daily at least 60 days per year.

Riser: The vertical pipe that carries water from one floor to another.

Sediment: Matter from piping or other water conveyance device that settles to the bottom of the water in the apparatus. If lead components are used in plumbing materials, lead sediments may form and result in elevated water lead levels.

Sequential Samples: Water samples collected at the fixture, one after another, without flushing beforehand or wasting water in between samples.

Service Line: Also called a connection line. The pipe that carries tap water from the public water main to a building. Service lines were often composed of lead materials, particularly those installed prior to 1986.

Source Water: Untreated water from streams, rivers, lakes or underground aquifers that is used to supply private wells and public drinking water.

Solder: A metallic compound used to seal the joints between pipes. Until 1986, solder containing up to 50 percent lead was legally used in potable water plumbing and the law prohibiting that may not have been enforced in your state until 1990. “Lead-free” solders, which can contain up to 0.2 percent lead, often contain one or more of the following metals: antimony, tin, copper or silver. Several alloys are available that melt and flow in a manner similar to lead solder.

Strainers: Are typically located within the fixture itself (e.g., at the inlet to a water fountain or cooler) and collect debris and/or sediment. These strainers should be checked and regularly cleaned since they can be a contributing source of elevated lead levels.

Valve: A mechanical device by which the flow of water may be started, stopped or regulated by a movable part that opens, shuts or partially obstructs one or more ports of passageway.

Water Cooler: A mechanical device affixed to drinking water supply plumbing that actively cools water for human consumption. The reservoir can consist of a small tank or a pipe coil.

Appendix B: Lead Water Coolers Banned in 1988

Lead Water Coolers Banned in 1988

The Lead Contamination Control Act (LCCA), which amended the Safe Drinking Water Act (SDWA), was signed into law on October 31, 1988 (P.L. 100-572). The potential of water coolers to contribute lead to drinking water in schools and child care centers was a principal focus of this legislation. Specifically, the LCCA mandated that the Consumer Product Safety Commission (CPSC) order the repair, replacement, or recall and refund of drinking water coolers with lead-lined water tanks. In addition, the LCCA called for a ban on the manufacture or sale in interstate commerce of drinking water coolers that are not “lead-free.” Civil and criminal penalties were established under the law for violations of this ban. With respect to a water cooler that may come in contact with drinking water, the LCCA (Section 1461 of SDWA) defines the term “lead-free” to mean:

not more than 8 percent lead, except that no drinking water cooler which contains any solder, flux, or storage tank interior surface which may come in contact with drinking water shall be considered “lead-free” if the solder, flux, or storage tank interior surface contains more than 0.2 percent lead.

Another component of the LCCA was the requirement that EPA publish and make available to the states a list of drinking water coolers, by brand and model, that are not “lead-free.” In addition, EPA was to publish and make available to the states a separate list of the brand and model of water coolers with a lead-lined tank. EPA is required to revise and republish these lists as new information or analyses become available.

Based on responses to a Congressional survey in the winter of 1988, three major manufacturers (the Halsey Taylor Company, EBCO Manufacturing Corporation, and Sunroc Corporation) indicated that lead solder had been used in at least some models of their drinking water coolers. On April 10, 1988, EPA proposed in the Federal Register (54 FR 14320) lists of drinking water coolers with lead-lined tanks and coolers that are not “lead-free.” Public comments were received on the notice, and the list was revised and published on January 18, 1990 (Part III, 55 FR 1772). See the following page for a list of water coolers and lead components included on that list.

Important Note: The 1990 list is based on a definition of “lead free” in SDWA applicable to drinking water coolers only (SDWA Section 1461). At the time it was enacted, the 8% standard of the definition was the same as the definition of lead free in another section of SDWA applicable to pipes, pipe fittings, plumbing fittings and fixtures, solder, and flux (SDWA Section 1417). Since then, however, the definition of “lead free” for pipes, fittings, and fixtures in Section 1417 was changed as a result of the 2011, **THE REDUCTION OF LEAD IN DRINKING WATER ACT** to a weighted average of 0.25 percent of the wetted surface. **It is still important to test fixtures that are not on this list; especially if they were installed prior to 2014, the year THE REDUCTION OF LEAD IN DRINKING WATER ACT became effective.**

List of Water Coolers and Lead Components

EBCO Manufacturing

All pressure bubbler water coolers with shipping dated from 1962 through 1977 have a bubbler valve containing lead. The units contain a single 50-50 tin-lead solder joint on the bubbler valve. Model numbers for coolers in this category are not available.

The following models of pressure bubbler coolers produced from 1978 through 1981 contain one 50-50 tin lead solder joint each.

CP3	DP15W	DPM8	7P	13P	DPM8H	DP15M	DP3R	DP8A
DP16M	DP5S	C10E	PX-10	DP7S	DP13SM	DP7M	DP7MH	DP7WMD
WTC10	DP13M-60	DP14M	CP10-50	CP5	CP5M	DP15MW	DP3R	DP14S
DP20-50	DP7SM	DP10X	DP13A	DP13A-50	EP10F	DP5M	DP10F	CP3H
CP3-50	DP13M	DP3RH	DP5F	CP3M	EP5F	13PL	DP8AH	DP13S
CP10	DP20	DP12N	DP7WM	DP14A-50/60				

Halsey Taylor

Lead solder was used in these models of water coolers manufactured between 1978 and the last week of 1987:

WMA-1	SCWT/SCWT-a	SWA-1	DC/DHC-1
S3/5/10D	BFC-4F/7F/4FS/7FS	S300/500/100D	

The following coolers manufactured for Haws Drinking Faucet Company (Haws) by Halsey Taylor from November 1984 through December 18, 1987, are not lead-free because they contain 2 tin-lead solder joints. The model designation for these unites are as follows:

HC8WT	HC14F	HC6W	HWC7D	HC8WTH	HC14FH	HC8W	HC2F	HC14WT
HC14FL	HC14W	HC2FH	HC14WTH	HC8FL	HC4F	HC5F	HC14WL	HCBF7F
HC4FH	HC10F	HC16WT	HCBF7HO	HC8F	HC8FH	HC4W	HWCZ	

Lead Lined Tanks

Prior to publication of the January 1990 list, EPA determined that Halsey Taylor was the only manufacturer of water coolers with lead-lined tanks. Below provides a listing of model numbers of the Halsey Taylor drinking water coolers with lead-lined tanks that had been identified by EPA as of January 18, 1990.

Based upon an analysis of 22 water coolers at a U.S. Navy facility and subsequent data obtained by EPA, EPA believes the most serious cooler contamination problems are associated with water coolers that have lead-lined tanks.

Since the LCCA required the CPSC to order manufacturers of coolers with lead-lined tanks to repair, replace, or recall and provide a refund of such coolers, the CPSC negotiated such an agreement with Halsey Taylor through a consent order published on June 1, 1990 (at 55 FR 22387). The consent agreement calls on Halsey Taylor to provide a replacement or refund program that addresses all the water coolers listed below as well as “all tank-type models of drinking water coolers manufactured by Halsey Taylor, whether or not those models are included on the present or on a future EPA list.” Under the consent order, Halsey Taylor agreed to notify the public of the replacement and refund program for all tank type models.

Currently, a company formerly associated with Halsey Taylor, Scotsman Ice Systems, has assumed responsibility for replacement of lead-lined coolers previously marketed by Halsey Taylor. If a school or child care facility has one of the Halsey Taylor water coolers noted below, contact Scotsman Ice Systems to learn more about the requirements surrounding its replacement and rebate program.

Scotsman Ice Systems

775 Corporate Woods Parkway Vernon Hills, IL 60061

PH: (800) SCOTSMAN or 800-726-8762

PH: (847) 215-4500

Halsey Taylor Water Coolers with Lead-Lined Tanks

The following six model numbers have one or more units in the model series with lead-lined tanks:

WM8A	WT8A	GC10ACR	GC10A	GC5A	RWM13A
------	------	---------	-------	------	--------

The following models and serial numbers contain lead-lined tanks:

WM14A Serial No. 843034	WM14A Serial No. 843006	WT11A Serial No. 222650
WT21A Serial No. 64309550	WT21A Serial No. 64309642	LL14A Serial No. 64346908

Appendix C: Develop a Code System for Samples

Develop a Code System for Samples

Code each outlet using a system that will allow each unique outlet to be identified by location, type and other relevant characteristics. The text below provides examples for coding by fixture type and sample type. The following is an example template that can be used to designate unique samples in single-building schools and child care facilities.

Floor-Room Number-Outlet Type-Sample Number

The following is an example that uses the structure above and the example codes to the right. An initial sample (P) was taken at a drinking water fountain (DW) on the 3rd floor (003) outside of room 312 (312) and is the 15th outlet counted (015). This sample would be coded as:

003-312-DW-P-015

If multiple buildings are being sampled, include the building number as well.

Building Number-Floor-Room Number-Outlet Type-Sample Number

Thus, if that same drinking water fountain was located in building 1 (01), it would be coded as:

01-003-312-DW-P-015

Important Note: when taking sequential samples, be sure to add a number to the sample to indicate the order the samples were taken in.

- **1SS** = First sequential sample
- **2SS** = Second sequential sample

For example, the first 125-mL sequential sample taken at that same drinking water fountain, would be coded as:

003-312-DW-1SS-015

Coding examples can include:

- DW = drinking water fountain
- WC = water cooler (chiller unit)
- CF = classroom faucet
- KF = kitchen faucet
- BF = bathroom faucet
- NS = nurse's office sink
- SC = service connector

As well as the type of sample taken:

- P = primary or initial sample
- F = flush
- SS = sequential sample

The coding should be identified on a site map, accompanied by a narrative that describes the observable conditions of each sampling location. It is also important to document any special conditions for the sampling, such as whether it was conducted after a remedy was implemented (e.g., after fixture/plumbing replacement, after POU filter installation), during a flushing evaluation (e.g., XX hours after morning flushing), or after aerator or inlet strainer cleaning so that results can be interpreted in the future.

Appendix D: Detailed Fixture Evaluation

The purpose of the detailed fixture evaluation is to pinpoint where (i.e., fixtures, cooler, interior plumbing) lead is getting into drinking water so that appropriate corrective measures can be taken.

Because the composition and dimensions of these fixtures vary, there are different sample collection procedures for each fixture. Using the partnerships established with the 3Ts Program, you may choose to request assistance with sampling from entities like public water systems, state drinking water programs or certified laboratories.

The following pages break down the sampling for five types of fixtures and explain how to interpret results:

- **Drinking Water Fountains**
- **Cold Water Faucet**
- **Drinking Water Fountains with Coolers**
- **Ice-Making Machine**
- **Central Chiller Unit**

Note: The graphics in this factsheet are meant to provide a general depiction of the plumbing being sampled. Each outlet is a little bit different; there may be instances where more or less of the plumbing is covered in the sample than is shown in the graphics.

Drinking Water Fountains

You will want to collect water so that the sample water has been in contact with the fixture and has been in contact with the connecting pipes (Exhibit 4). If the fountain has a chiller unit, see the [Central Chiller Unit Section](#) for additional sampling.

Helpful hint: Read the full instructions before sampling.



Sample 1A: Sampling the Outlet

Take this sample before the facility opens and before any water is used. Try to predict the arc of the water and take a 125-mL sample. Note this is a sequential sample. This sample is representative of the water that may be consumed at the beginning of the day or after infrequent use. It consists of water that has been in contact with the fountain or bubbler valve, shut-off valve and connecting pipe.



Sample 2A: Sampling the Connecting Pipe

Without shutting off the water, take another 125-mL sample, trying not to spill. Be sure to record which sample was the first and which was the second sample. This is also a sequential sample.

This sample consists of water that has been in contact with the plumbing upstream of the outlet and the lateral pipe.



Sample 3A: Sampling the Interior Plumbing

Again, without shutting off the water, take a final 250-mL sample trying not to spill any water in between samples. This is also a sequential sample. This sample is representative of the water that is in the plumbing upstream from the fountain.

Exhibit 4. Targeted Locations of Water in Plumbing for Drinking Water Faucets

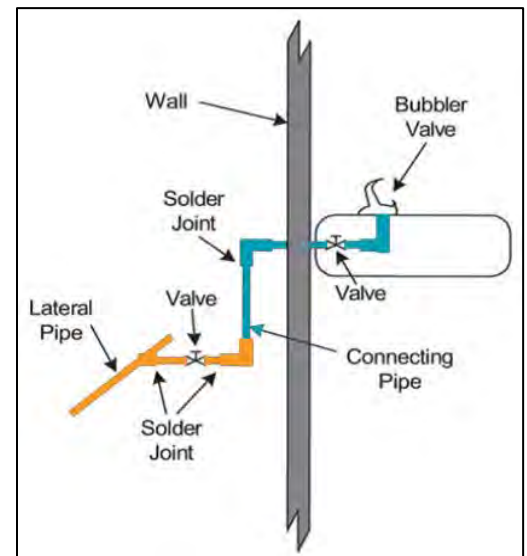

Interpreting Results: Drinking Water Fountains

To determine the source of lead in the water, compare the test results of samples **1A**, **2A** and **3A**.

- **IF** the lead level in the first 125-mL sample (**1A**) is higher than that of the second-125 mL sample (**2A**), **THEN** the fixture may be contributing lead and might need to be replaced.
- **IF** the lead level in the second 125-mL sample (**2A**) is higher than that of the first sample (**1A**), **THEN** the lateral pipe or shut-off valve may be contributing lead.

- **IF** the lead level in the 250-mL sample (**3A**) is lower (below 5 ppb), **THEN** very little lead is being picked up from the plumbing upstream from the outlet. The majority or all of the lead in the water is likely contributed from the drinking water fountain.
- **IF** the lead level in the 250-mL sample (**3A**) significantly exceeds 5 ppb (for example, 10 ppb), **THEN** lead in the drinking water could also be contributed by the plumbing upstream of the drinking water fountain. Compare all sample results to prioritize follow-up sampling and remediation. Outlets with elevated lead levels should not be made available for consumption.

Cold Water Faucet (i.e., Water Faucet, Water Tap, Kitchen Sink)

Water in this sample should consist of water that has been in contact with the faucet fixture and the lateral pipe (Exhibit 5).



Sample 1B: Sampling the Faucet

Take a 250-mL sample before the facility opens and before any water is used. **Note this is a sequential sample.**

Sample **1B** is representative of the water that may be consumed at the beginning of the day or after infrequent use. It consists of water that has been in contact with the fixture and the plumbing connecting the faucet to the lateral pipes. See Exhibit 5.



Sample 2B: Sampling the Interior Plumbing

Without shutting off the water, take a second 250-mL sample, trying not to spill. Note this is also a sequential sample.

This sample is representative of the water that is in the plumbing upstream from the faucet.

Interpreting Results: Cold Water Faucets

To determine the source of lead in the water, compare the results of samples **1B** and **2B**.

Exhibit 5. Targeted Locations of Water in Plumbing for Cold Water Faucets

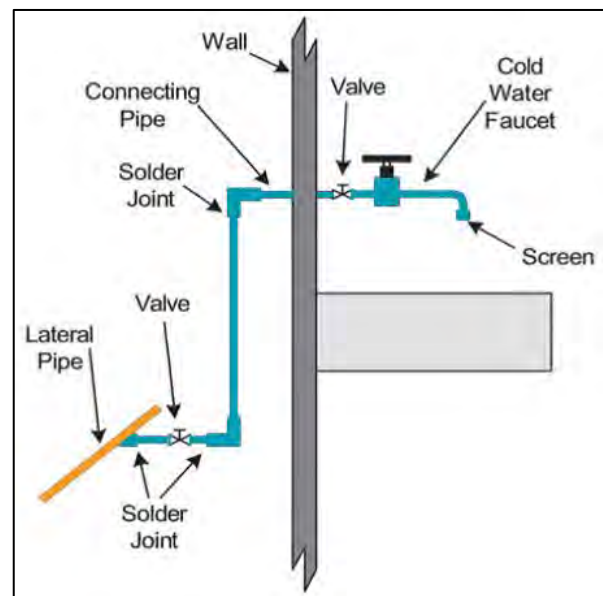

- **IF** the lead level in sample **1B** is higher than that in sample **2B**, **THEN** the source of lead could be the water faucet and/or the plumbing upstream from the faucet.
- **IF** the lead level in sample **2B** is lower, close to 5 ppb, **THEN** very little lead is coming from the plumbing upstream from the faucet. The majority or all of the lead in the water is likely from the faucet and/or the plumbing connecting the faucet to the lateral.
- **IF** the lead level in sample **2B** significantly exceeds 5 ppb (for example, the level is 10 ppb), **THEN** lead may be coming from the plumbing upstream from the faucet.

Drinking Water Fountains with Coolers

Two types of water coolers are used in drinking water fountains: the wall-mounted and the free-standing types. Water in these coolers is stored in a pipe coil or in a reservoir. Refrigerant coils in contact with either of these storage units cool the water. Sources of lead in the water may be the internal components of the cooler, including a lead-lined storage unit; the section of the pipe connecting the cooler to the lateral pipe; and/or the interior plumbing of the building (Exhibit 6).



Flushing the Afternoon Before

In order to sample this outlet, you need to flush the outlet the afternoon before sampling. Flushing times will be dependent on the cooler tank size, but a 15-minute flush should get to the piping upstream of the cooler and ensure that no stagnant water is left in the storage unit.



Sample 1C: Sampling the Outlet

Take a 125-mL sample before the facility opens and before any water is used. Collect the water immediately after opening the fountain or bubbler valve without allowing water to run.

Note this is a sequential sample.

The sample consists of water that has been in contact with the fountain or bubbler valve and the plumbing inside the outlet.



Sample 2C: Sampling the Water Cooler

Without shutting off the valve, take a 250-mL sample immediately after sample **1C**, trying not to spill any water. **This is also a sequential sample.**

Because the water in the cooler was flushed the previous afternoon, this sample is representative of the water that was in contact with the cooler overnight, not in extended contact with the plumbing upstream.

Interpreting Results: Drinking Water Fountain Coolers

To determine the source of lead in the water, compare the test results of samples **1C**, **2C**, and **3C**.

- **IF** the lead level concentration in the first 250-mL sample (**2C**) is high AND is greater than or equal to the lead level concentration of sample **1C**, THEN the source of the lead may be sediments contained in the cooler storage tank, screens or the plumbing upstream from the cooler.
- **IF** the lead level concentration in the first 125-mL sample (**1C**) is greater than the sample **2C** concentration, THEN bubbler valve may be contributing lead.

Exhibit 6. Targeted Locations of Water in Plumbing for Water Fountains with Coolers

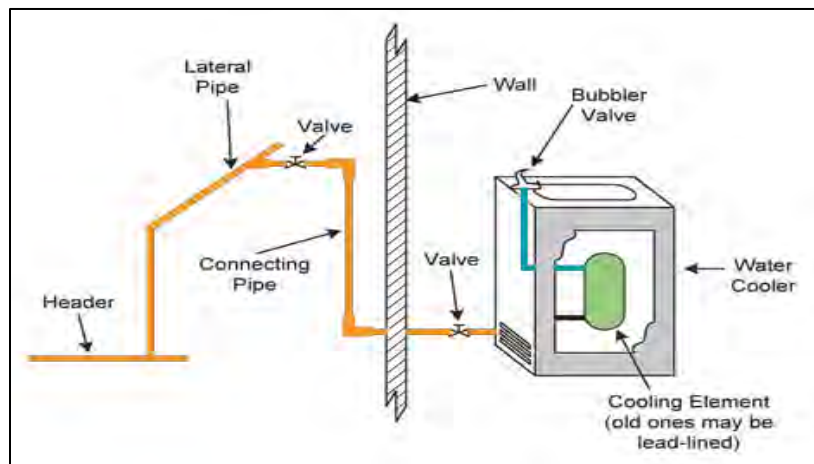

Eliminating Particulate Lead as a Source

If the detailed fixture results reveal there are high lead levels of lead in the cooler sample, a contributing source of the elevated levels could be the debris in the aerator or screen of the fixture. By cleaning the aerator or screen and retesting, you can determine whether the debris is a contributing source to elevated lead levels in their facilities.

Determining aerator/screen debris contribution:

Turn off the valve leading to the cooler. Disconnect the cooler from the plumbing and look for a screen at the inlet. Remove the screen. Some coolers also have a screen installed at their bubbler or fountain valve. Carefully remove the valve by unscrewing it. Some coolers are equipped with a drain valve at the bottom of the water reservoir that may also catch debris. Clean it all. Then take a 250-mL sample (**3C**).

Interpreting Results: Cooler

- **IF** the concentration of sample **3C** is less than 5 ppb **THEN** the lead could be coming from debris in the cooler or the screen.
- **IF** the concentration of sample **3C** is much greater than 5 ppb **THEN** the lead is likely coming from debris in the cooler or on the screen.
- **IF** the concentration of sample **3C** is much greater than 5 ppb **AND** less than sample **1C THEN** the source of lead may be sediments contained in the cooler, screens, and/or the upstream plumbing. Routine flushing practices should be implemented to reduce exposure from lead particulates.

Ice-Making Machine

You will want to collect water so that the sample water has been in contact with the ice making machine and with the plumbing upstream (Exhibit 7).



Sample 1D: Sampling the Ice

Fill a suitable container (250-mL or larger, wide-mouthed bottle or other container) provided by the laboratory at least three-quarters full with ice. Do not touch the ice with bare hands. Use the non-metal scoop or disposable plastic gloves provided by the laboratory to place the ice in the container. The results of **1D** can be used to determine if sample **2D** is needed.

Note: If there are high lead levels in the initial sample (**1D**), then collect sample **2D** to determine if the source of the lead is the plumbing or the ice making machine itself.



Sample 2D: Sampling the Plumbing

Disconnect the ice maker from the plumbing and look for a screen at the inlet. Remove the screen. Clean out the debris, if debris is present. Clean the screen routinely to avoid accumulations of debris.

Collect the sample from the disconnected plumbing as close to the ice maker as possible. Fill the sample container with 250-mL of water immediately after opening the faucet or valve. If no faucet is available, contact the ice machine manufacturer for recommendations that will minimize disruption of existing plumbing.

Exhibit 7. Targeted Locations of Water in Plumbing for Ice Making Machines

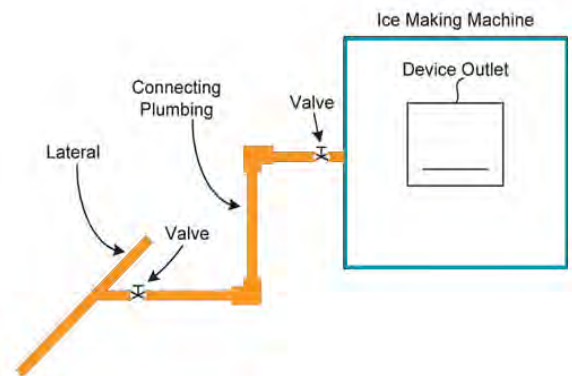

Interpreting Results: Ice-Making Machine

- **IF** the lead level in sample **2D** is lower (below 5 ppb), **THEN** the source of the lead may be in the ice maker.
- **IF** the lead level in sample **2D** significantly exceeds 5 ppb (for example, the level is 10 ppb), **THEN** lead could also be contributed from the plumbing upstream from the ice maker.
- Follow-up samples from the supplying system may also need to be taken to identify the source of lead.

Central Chill Unit



Sample 1E: Sampling the Plumbing Supplying the Chiller

Take a 250-mL sample from a faucet or valve as close to the inlet of the chiller as possible. If no outlet is available, contact the chiller manufacturer for recommendations that will minimize disruption of existing plumbing. If a sample faucet or valve is available, collect the sample immediately after opening the outlet, without allowing any water to go to waste.

This sample is representative of water that has been in contact with the plumbing supplying water to the chiller.



Sample 2E: Sampling the Connecting Pipe

Take a 250-mL sample from a faucet or valve as close to the outlet of the chiller as possible. If no outlet is available, contact the chiller manufacturer for recommendations that will minimize disruption of existing plumbing.

This water sample consists of water that has been in contact with the chiller unit and the plumbing upstream, which supplies water to the chiller. Often, water supplied to the fountains is recirculated to the chiller unit. In this instance, sample **2E** consists of a mixture of water from the water supply and any water that may be recirculated from the plumbing supplying water to the fountains.

Interpreting Results: Central Chiller Unit

Note: You will need the results from samples collected at the drinking water fountain (Exhibit 4) covered earlier in this section.

- **IF** the lead level in sample **3A** (the drinking water fountain sample) is higher than that in sample **2E** (the second 250-mL central chiller sample), **THEN** lead could be contributed by the plumbing supplying the water from the chiller to the fountain.
- **IF** the lead level in sample **2E** is higher than in sample **1E**, **THEN** a portion of the lead may be coming from the chiller.
 - **Note:** Sludge and sediments containing high levels of lead may accumulate in chiller tanks. If the test results indicate that lead is coming from the chiller unit, check for the presence of debris and sludge. Remove any of these materials from the chiller, flush the chiller unit, and resample the water.
- **IF** the lead level in sample **1E** is lower (close to 5 ppb), **THEN** very little lead is being picked up from the plumbing upstream from the chiller. The majority of the lead in the water may be attributed to the chiller and the plumbing downstream from the chiller.
- **IF** the lead level in sample **1E** is very high (above 20 ppb), **THEN** there could be lead sources upstream from the chiller and you may need to contact a plumber to further diagnose.

Exhibit 8: Targeted Locations for Water in Plumbing for Central Chillers

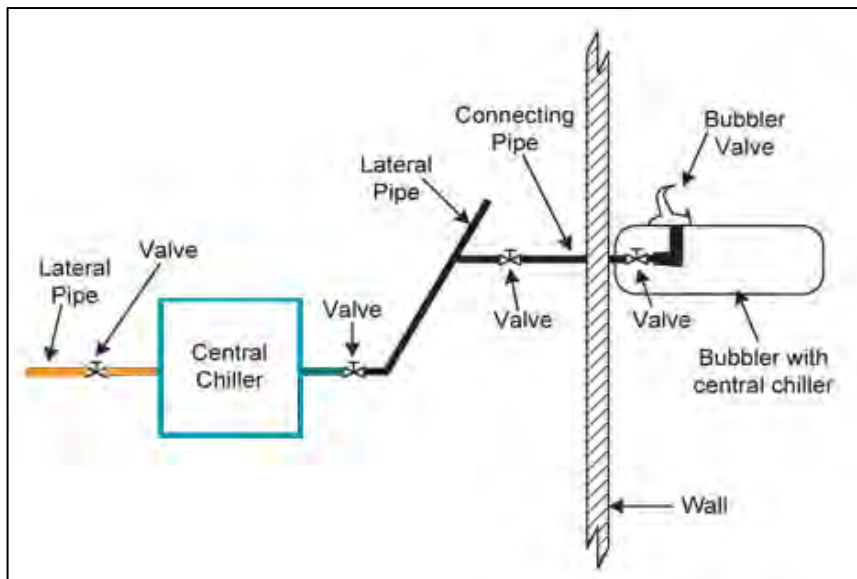

Additional Sampling Information

Sample Documentation

Record the unique sample identification number on each sample bottle and on the recordkeeping form. An example form is provided in Appendix F. The information recorded will include:

- Type of sample taken (e.g., initial first-draw)
- Date and time of collection
- Name of the sample collector
- Location of the sample site
- Name of the outlet manufacturer, and the outlet's model number, if known
- Model number of faucets, valves, and other visible fixtures; include digital photos in sampling records, if possible
- Water treatment already in place in the building (i.e., point-of-entry (POE) devices) or filters (point-of-use (POU) devices).

Additional Interior Plumbing Samples

In general, if lead levels remain high in samples taken from drinking water outlets, and the source cannot be determined, additional samples from upstream sample sites in the interior plumbing should be collected. The Detailed Fixture Evaluation can further help in determining potential lead sources.

The configuration of interior plumbing will vary depending on the layout of a given building and type of outlet. Construction materials may also vary, especially in larger buildings where additions and repairs have been made to the original structure.

At this point, if not done already, you may also want to contact a professional to assist in collecting interior plumbing samples. you should also consider the installation of filters.

Sampling for Other Parameters

In addition to monitoring for lead, you may wish to monitor for other parameters that may provide an indication of problems in your plumbing. However, note that analysis costs will increase as the number of parameters increases. Some other parameters include bacteria, cadmium, color, copper, iron, turbidity, and zinc. See Table below.

Contaminant	Limit	Concern
Bacteria	Absent	Bacteria are present throughout our environment. They have adapted to live and reproduce in a variety of environments, including inside animals and humans, and in water, soil, and food. If bacteria are present in drinking water sources, most are removed during the disinfection process. However, some may survive and enter the distribution system (the building's pipes and plumbing). Bacteria can also grow within the plumbing system, water fountains, and faucets.
Cadmium	5 ppb	A regulated toxic metal found in low levels in galvanized pipe. The maximum allowable level at the water treatment plant is 5 ppb. However, the presence of cadmium at any level indicates that corrosive conditions may exist in the plumbing.
Color	15 color units	An aesthetic parameter that may indicate the presence of iron oxides. Iron oxides are often present in iron or steel pipe as a result of corrosive conditions.
Copper	1300 ppb	A regulated metal used to make copper piping. The presence of copper in water samples taken from copper piping is not unusual, but higher levels indicate that corrosive conditions may be a concern.
Iron	300 ppb	An aesthetic parameter that is indicative of corrosive conditions at higher levels. See also color and turbidity. (Galvanized pipe is made of iron.)
Turbidity	1 turbidity unit	A measurement of the clarity of water. Higher turbidity values may indicate the presence of iron oxides. Iron oxides are often present in iron or steel pipe as a result of corrosive conditions.
Zinc	5000 ppb	An aesthetic parameter that is indicative of corrosive conditions at higher levels. Zinc is used in making galvanized piping products. The presence of zinc in water samples taken from galvanized piping is not unusual, but higher levels indicate that corrosive conditions may be a concern.

Appendix E: Preservation of Samples

In order to avoid analytical errors, pay particular attention to proper collection and handling of the sample before analysis. Sample containers (250-mL) should be obtained from a certified laboratory. The containers should have wide openings for easier sample collection and to allow samples to be collected with the water flowing at normal flow rates (i.e., A container with a narrow opening would make it difficult to collect water from a faucet that is turned on at the normal flow rate. Water collected from a faucet that is turned on “low” may not be representative of normal usage.) Other containers such as used jars or water bottles should not be used.

Make sure the containers are kept sealed between the time of their preparation by the lab and the collection of the sample. This will assure that no contaminants from the outside are introduced. If also taking bacteria samples, preserve the samples by icing, and promptly ship or deliver it to the laboratory. Most laboratories will provide the necessary shipping containers and cold packs. Upon receipt, the laboratory will acidify the sample. The sample can be held up to 14 days prior to acidification without loss of lead through absorption, but EPA recommends that you ship your samples as soon as possible.



It is best to have water samples analyzed for “total lead” rather than “dissolved lead.” Many laboratories may recommend the dissolved lead test because it is cheaper, but this test does not analyze for particulate lead, which can only be measured using the “total lead” test. However, both tests can also be conducted in order to determine if particulate lead is a problem. The difference in value of lead between the two results can be used to calculate particulate lead.

A certified drinking water laboratory should be aware of these requirements. In addition, the laboratory may provide qualified individuals to collect samples or sample containers and instructions. The sample containers may have been prepared prior to reaching the school or child care facility. The laboratory will also specify how to handle the sample containers and when to submit them after taking the samples.

When the laboratory returns the test results, the concentrations of lead in the drinking water samples will be reported in metric form such as milligrams per liter (mg/L) or micrograms per liter ($\mu\text{g/L}$), or they will be reported as a concentration such as parts per million (ppm) or parts per billion (ppb), respectively.

Milligrams per liter (**mg/L**) is the same as parts per million (**ppm**).

Micrograms per liter (**$\mu\text{g/L}$**) is the same as parts per billion (**ppb**).

Examples:

- $1 \text{ mg/L} = 1000 \text{ } \mu\text{g/L} = 1 \text{ ppm} = 1000 \text{ ppb}$
- $0.020 \text{ mg/L} = 20 \text{ } \mu\text{g/L} = 0.02 \text{ ppm} = 20 \text{ ppb}$

For more detailed information, refer to the following documents:

Methods for the Determination of Metals in Environmental Samples. U.S. EPA/600/4-94/111. May 1994 (available from the National Technical Information Service, Pub. No. PB95-125472 (703) 487-4650).

Manual for the Certification of Laboratories Analyzing Drinking Water. U.S. EPA 815-R-05-004. January 2005 (available from the National Technical Information Service (703) 487-4650).

Standard Methods for the Examination of Water and Wastewater, 22nd Edition. Co-published by the American Public Health Association, the Water Environment Federation and the American Water Works Association. 2012 (available from the American Water Works Association, ISBN # 0-87553-013-3, Catalog #10085).



Appendix F: Example Sampling Field Form

Building Name:		Sample Date (MM/DD/YYYY):		Sampler's Email:			
Building Number:		Sampler's Name:		Sampler's Phone:			
Sample Id = Building Number-Floor-Room Number-Outlet Type-Sample Number (e.g., 01-03-312-DW-P-015)							
<u>Outlet Type Codes</u>							
DW = drinking water fountain		KF = kitchen faucet		WC = water cooler (chiller unit)		BF = bathroom faucet	
CF = classroom faucet		NS = nurse's office sink					
Sample ID	Model #	Time	Color <i>(describe)</i>	Filter <input type="checkbox"/> Yes <input type="checkbox"/> No	Filter Date <i>(MM/DD/YYYY)</i>	Location Notes	Lab Sample ID <i>(Lab use only)</i>
01-03-312-DW-P-015	SF – 7080	5:30am		<input type="checkbox"/> Yes <input type="checkbox"/> No	10/14/2016	DW in next to room 312	
Chain of Custody:							
1. Released By:		Received By:		Date/Time:		#of Samples:	
2. Released By:		Received By:		Date/Time:		#of Samples:	
3. Released By:		Received By:		Date/Time:		#of Samples:	
General Notes:							

Appendix G: Plumbing Profile

This questionnaire is designed to assist with determining whether lead is likely to be a problem in a facility. A separate plumbing profile may be needed for each building, addition or wing of the facility, especially if the construction of each took place at different times. The questions in the left column will help to determine whether lead is likely to be a problem in a facility and will enable sampling effort prioritization. The middle column is where questions should be answered. Use the right column as a guide to interpret the answers and gain a better understanding of the significance of possible answers. Some of the questions in this questionnaire may not apply to a facility for various reasons. Skip those questions that do not apply.

Plumbing Profile Question	What Answers to the Plumbing Profile Questions Mean
<p>1. When was the original building constructed?</p> <p>Were any buildings or additions added to the original facility? If so, complete a separate plumbing profile for each building, addition or wing.</p>	<p>Older Buildings – Through the early 1900s, lead pipes were commonly used for interior plumbing in certain parts of the country. Plumbing installed before 1930 is more likely to contain lead than newer pipes. After 1930, copper generally replaced lead as the most commonly used for water pipes. Up until the mid- to late-1980s (until the “lead-free” requirements of the 1986 Safe Drinking Water Act Amendments took effect), lead solder was typically used to join these copper pipes. The efforts of a public water system over the years to minimize the corrosiveness of the water may have resulted in a protective coating of mineral deposits forming on the inside of the water pipes (passivation). This coating insulates the water from the plumbing and generally results in decreased lead levels in water. If the coating does not exist or is disturbed, the water is in direct contact with any lead in the plumbing system.</p> <p>Newer Buildings – New buildings are not likely to have lead pipes in their plumbing systems, but they are very likely to have copper pipes with solder joints. Buildings constructed prior to the late 1980s, before the “lead-free” requirements of the 1986 Safe Drinking Water Act Amendments, may have joints made of lead solder. Buildings constructed after this period should have joints made of “lead-free”</p>

Plumbing Profile Question	What Answers to the Plumbing Profile Questions Mean
	<p>solders. In addition, “lead-free” brass fixtures or plumbing components purchased or installed prior to 2014, the Reduction of Lead in Drinking Water Act effective date, were allowed to contain higher levels of lead. Even if “lead-free” materials were used in new construction and/or plumbing repairs, lead leaching may occur. See the Training Section for more information on the “lead-free” requirements.</p>
<p>2. If built or repaired since 1986, were “lead-free” plumbing and solder used in accordance with the “lead-free” requirements of the 1986 Safe Drinking Water Act Amendments? What type of solder has been used?</p>	<p>The 1986 Safe Drinking Water Act Amendments banned plumbing components that contained elevated levels of lead. The Reduction of Lead in Drinking Water Act further reduces lead in pipes, pipe fittings, plumbing fittings, and fixtures to a weighted average of 0.25 percent. The Act also redefines “lead-free” under the SDWA to mean: not containing more than 0.2 percent lead when used with respect to solder and flux and not more than a weighted average of 0.25 percent lead when used with respect to the wetted surfaces of pipes, pipe fittings, plumbing fittings, and fixtures. These provisions went into effect in January 2014.</p> <p>In some areas of the country, it is possible that high-lead materials were used until 1988 or perhaps even later. The local plumbing code authority or building inspector may be able to provide guidance regarding when high-lead materials were last used on a regular basis in the area.</p> <p>If “lead-free” materials were not used in new construction and/or plumbing repairs, elevated lead levels can be produced. If the film resulting from passivation does not exist or has not yet adequately formed, any lead that is present is in direct contact with the water.</p>

Plumbing Profile Question	What Answers to the Plumbing Profile Questions Mean
<p>3. When were the most recent plumbing repairs made? Note the locations.</p>	<p>If the building (or an addition, new plumbing, or repair) is less than 5 years old and lead solder or other leaded materials were used (e.g., brass fixtures containing lead alloys, especially those purchased or installed prior to 2014 when the Reduction of Lead in Drinking Water Act took effect), elevated lead levels may occur. If water supplied to the building is corrosive, lead can remain a problem regardless of the plumbing’s age.</p>
<p>4. Of what materials is the service connection (the pipe that carries water to the school or child care facility from the public water system’s main in the street) made?</p> <p>Note the locations where the service line enters the building and connects to the interior plumbing.</p>	<p>Lead piping was often used for the service connections that join buildings to public water systems. In larger schools, the service line is probably not lead because lead is impractical for the larger service lines typically used in these facilities; however, many child care facilities reside in small buildings and are at a higher likelihood of being served by lead lines.</p> <p>Some localities required the use of lead service connections up until the “lead-free” requirements of the 1986 Safe Drinking Water Act Amendments took effect. Although a protective layering of minerals may have formed on these pipes, vibrations can cause flaking of any protective build-up and, thus, allow lead contamination to occur.</p>
<p>5. What are the potable water pipes made of in the facility?</p> <p>Examples include: Lead, plastic, galvanized metal, cast iron, copper, other.</p> <p>Note the location of the different types of pipe, if applicable, and the direction of water flow through the building.</p>	<p>Survey the building for exposed pipes, preferably accompanied by an experienced plumber who should be able to readily identify the composition of pipes on site. Most buildings have a combination of different plumbing materials.</p> <p>Lead pipes are dull gray in color and may be easily scratched by an object such as a knife or key. Also, a magnet will not stick to lead.</p> <p>Galvanized metal pipes are gray or silver-gray in color and are usually fitted together with threaded joints. A magnet will stick to galvanized iron pipe. In some instances, compounds containing lead have been used to seal the threads joining the pipes. Debris from this material, which has fallen inside the pipes, may be a source of contamination.</p>

Plumbing Profile Question	What Answers to the Plumbing Profile Questions Mean
<p>Note the areas of the building that receive water first, and which areas receive water last.</p>	<p>Copper pipes are red-brown in color. Corroded portions may show green deposits. Copper pipe joints were typically joined together with lead solders until the “lead-free” requirements of the 1986 Safe Drinking Water Act Amendments took effect.</p> <p>Plastic pipes, especially those manufactured abroad, may contain lead. If plastic pipes are used, be sure they meet NSF International standards, http://info.nsf.org/Certified/pwscomponents/.</p>
<p>6. Are there tanks in the plumbing system (e.g., pressure tanks or gravity storage tanks)?</p> <p>Note the locations of any tanks, and any available information about the tank (e.g., manufacturer or date of installation).</p>	<p>Some older tanks may contain coatings that are high in lead content.</p> <p>Tanks may accumulate sediment that could be flushed back into the plumbing system under certain circumstances. You may wish to contact the supplier or manufacturer to obtain information about coatings. They may also wish to hire a plumber or tank service contractor to inspect the tanks, especially gravity storage tanks that are located outside of the building.</p> <p>Although EPA encourages routine maintenance of hot water heaters, this guidance does not include sampling hot water outlets or hot water heaters, because hot water is not recommended for consumption (drinking/cooking). See Temperature Control Establishing Routine Practices in the Taking Action Section.</p>
<p>7. Was lead solder used in the plumbing system?</p> <p>Note the locations with lead solder.</p>	<p>The 1986 Safe Drinking Water Act Amendments banned plumbing components that contained high levels of lead. It is likely that high-lead solder and fluxes continued to be used until 1988 and even later in some areas of the country. The local plumbing code authority or building inspector may be able to provide guidance regarding when high-lead solder was last used on a regular basis in the area. It is important to note that the Reduction of Lead in Drinking Water Act did not revise the “lead-free” definition for solder and flux.</p>

Plumbing Profile Question	What Answers to the Plumbing Profile Questions Mean
<p>8. Are brass fittings, faucets or valves used in the drinking water system? (Note: Most faucets are brass on the inside.)</p> <p>You may want to note the locations on a map or diagram of their facilities and make extensive notes that would facilitate future analysis of lead sample results.</p>	<p>Brass fittings, faucets, and valves are golden yellow in color, similar to copper in appearance, or are plated with chrome. After 1996, brass fittings installed in drinking water outlets such as faucets and water coolers were required to meet NSF/ANSI standards for lead content (NSF/ANSI 61, NSF/ANSI 372). While this percentage was considered “lead-free” under the 1986 Safe Drinking Water Act Amendments, some contamination problems still may occur. Older brass faucets and components may contain higher percentages of lead and lead solder in their interior construction and pose contamination problems. Note that state or local governments may have imposed this standard prior to 1988.</p> <p>The degree to which lead will leach from brass products containing alloys with less than 8 percent lead is dependent upon the corrosiveness of the water and the manufacturing process used to develop the product. You should request NSF/ANSI 61 certification on all drinking water system products purchased. Include a copy of the NSF/ANSI 61 certificate as a requirement on the purchase orders. The distributor or manufacturer can provide a list of certified products. NSF 372 covering pipes, pipe fittings, plumbing fittings, and fixtures was adopted in 2010, and dictates that a product has been certified as meeting a weighted average lead content of less than or equal to 0.25 percent when used with respect to wetted surfaces. See EPA’s 2013 guidance, How to Identify Lead-Free Certification Marks for Drinking Water System & Plumbing Materials for additional guidance.</p> <p>The Reduction of Lead in Drinking Water Act further reduces lead in pipes, pipe fittings, plumbing fittings, and fixtures to a weighted average of 0.25 percent. These provisions went into effect in January 2014.</p>

Plumbing Profile Question	What Answers to the Plumbing Profile Questions Mean
<p>9. How many of the following outlets provide water for consumption?</p> <p>Water coolers, water fountains with central chillers, cold water taps, ice makers, kitchen taps, or drinking fountains. Note the locations.</p>	<p>In addition to lead components in the plumbing system, lead solders or lead in the brass fittings and valves used in some faucets, fountains, and refrigerated water coolers may be sources of lead. It is important to identify the locations of all such drinking water outlets. Faucets in bathrooms should not be used to obtain water for drinking. Although they may be adequate for washing hands, they may not be appropriate for drinking purposes. However, if bathroom faucets, locker room showerheads, and non-traditional drinking water outlets are known to be used for drinking or cooking (e.g., fill water jugs), sampling should be conducted. You may consider posting “Do Not Drink or Cook” signs.</p>
<p>10. Have you checked the brands and models of water coolers and compared them to the listing of banned water coolers in Appendix B of this document?</p> <p>Note the locations of any banned coolers.</p>	<p>Older water coolers (purchased or installed prior to 1988) may be a major source of lead contamination. See Appendix B of this manual for a summary of EPA’s list of water coolers found to contain lead. Use the list to help prioritize sampling. If a water cooler is listed as having a lead-lined tank, its water should not be used for drinking, and the cooler should be removed immediately, as these coolers pose the highest risk of contamination.</p>
<p>11. Do outlets that provide drinking water have accessible screens or aerators? (Standard faucets usually have aerator or screens. Many coolers and fountains also have inlet strainer screens.) If so, have the screens been cleaned?</p> <p>Note the locations.</p>	<p>Lead-containing sediments that are trapped on screens can be a significant source of lead contamination. Facilities should create a routine maintenance program to clean the screens regularly. See Cleaning in Establishing Routine Practices of the Taking Action Section. If sediment has been a recurring problem, regular cleaning of the screens and additional investigation of the reasons for the debris accumulation is appropriate. However, the manufacturer or water service provider should be contacted to obtain instructions for cleaning screens.</p>

Plumbing Profile Question	What Answers to the Plumbing Profile Questions Mean
<p>12. Are there signs of corrosion, such as frequent leaks, rust-colored water, or stained dishes or laundry?</p> <p>Note the locations.</p>	<p>Frequent leaks, rust-colored water, and stains on fixtures, dishes, and laundry are signs of corrosive water. Blue-green deposits on pipes and sinks indicate copper corrosion; brown stains result from the corrosion of iron. Where such symptoms occur, high levels of lead, copper, and iron may be present in the water.</p>
<p>13. Is any electrical equipment grounded to water pipes?</p> <p>Note the locations.</p>	<p>If electrical equipment has been installed using water pipes as a ground, the electric current traveling through the ground wire will accelerate the corrosion of any interior plumbing containing lead. This practice should be avoided, if possible. However, if existing wires are already grounded to water pipes, the wires should not be removed from the pipes unless a qualified electrician installs an alternative grounding system. Check with the local building inspector on this matter. State or local building codes may require grounding of the wires to the water pipes. Improper grounding of electrical equipment may cause severe shock.</p>
<p>14. Have there been any complaints about bad (metallic) taste?</p> <p>Note the locations.</p>	<p>Although lead dissolved in water cannot be seen, tasted or smelled, the presence of a metallic taste or rusty appearance may indicate corrosion and possible lead contamination.</p>

Plumbing Profile Question	What Answers to the Plumbing Profile Questions Mean
<p>15. Check building files and ask the public water system to determine whether any water samples have been taken from the building for any contaminants.</p> <p>Name of contaminant(s)? What concentrations of the contaminant(s) were found? What was the pH? Is testing done regularly at the facility?</p>	<p>As discussed in the Training Section, lead testing may have previously been done voluntarily under the Lead Contamination Control Act. Results of analyses of general water quality, such as measures of pH, calcium hardness, and carbonate alkalinity, can provide important clues about the corrosiveness of the water. If there is no data from the school or child care facility, the public water system should at least be able to provide information about the general water quality.</p>
<p>16. Other plumbing questions:</p> <p>Are blueprints of the building available? Are there known plumbing “dead-ends,” low use areas, existing leaks or other “problem areas?” Are renovations being planned for part or all of the plumbing system?</p>	<p>You should incorporate this information into decisions regarding sample locations and sampling protocol. They may wish to note the direction of water flow and the location of fixtures, valves, tanks, areas of sediment accumulation, areas of corrosion, etc., on a sketch or blueprint of the plumbing.</p>

ATTACHMENT A13c
APPENDIX A
SAMPLING GUIDANCE
Collecting Drinking Water Samples
for Lead Testing At K-12 Schools

This Sampling Guidance is provided by the State Water Resources Control Board (SWRCB) Division of Drinking Water for use by schools and water system staff who will be participating in the collection of samples for the determination of lead in drinking water at K-12 schools. Sampling and testing will be used to help reduce students and staff exposure to lead in the drinking water provided at the school.

This guidance and the instructions for sampling are taken from the US Environmental Protection Agency's 3Ts (Testing, Training, and Telling) for Reducing Lead in Drinking Water in Schools program for measuring and reducing lead at school drinking water locations; however, there are differences between the EPA and SWRCB sampling procedures. The SWRCB procedures used for this testing includes initial sampling to determine the combined lead concentration from the outlet device (bubbler, sink faucet, fountain, etc.) and from the internal plumbing, and repeat sampling to confirm initial sampling test results or to determine the lead concentration after routine, interim, and permanent corrective actions to reduce lead from an outlet device have been completed.

To ensure accurate test results the samples should be collected by following the instructions below for preparation, initial sampling, and repeat sampling.

Preparation

1. At least one school employee should be designated to assist the water system trained sampler during the collection of initial, repeat, confirmation, and check samples and to provide any additional help as necessary to complete the sampling.
2. Select up to five of the busiest locations used for drinking and cooking to be sampled and tested. These locations can be selected by observing students and staff during the morning, break, and lunch periods over as many days as needed until the busiest locations have been identified. The DDW database can accept up to 26 locations (25 sample sites and 1 distribution source site) to be sampled for testing.
3. All faucets, fountains, coolers, bubblers, bottle filling stations, and filtered water dispensers located on the exterior and interior of buildings, including those located in hallways, playgrounds, classrooms, and cafeterias, should be evaluated to assure that all locations have been considered for selection. Large industrial sinks designed for washing and not intended to be used as a source of water for drinking and cooking should not be included.
4. Do not omit from the evaluation and selection process drinking water locations that are served by a point of use filter (a filter attached to the faucet or under the sink) or drinking water locations in buildings or school ground areas that are served by a water softening, conditioning, or filtration treatment system.
5. Each location selected for testing should be assigned a Sample ID. Each Sample ID should use the following format: <Water System No.>-<School ID>-<Sample ID> i.e. 1710001-AAC-A. All repeat, confirmation, and corrective actions samples collected at a location are to be assigned the same Sample ID.
6. A Lead Sampling Plan should be prepared that includes all sample locations and Sample IDs identified on a map of the school grounds. Only water system staff trained in sampling should be collecting the samples. A water system may train a school employee to perform the sampling if necessary.
7. All samples should be collected on a Tuesday, Wednesday, Thursday or Friday morning during periods of normal school operations (school is in session) and not during summer

ATTACHMENT A13c

school, summer or winter breaks, or other extended breaks. Do not collect the samples on the first day back to school following a vacation, holidays, or weekends.

8. Record the location description, date and time last used, and date and time collected in the Lead Sampling Plan.
9. All samples must be “first draw samples” meaning that at the time of sampling the drinking water locations must not have been used during the previous 6 hours. To ensure this period of inactivity it may be necessary to protect the sample locations overnight prior to collecting the samples early in the morning before students and staff arrive.
10. Do not flush a sample site for any length of time prior to the 6 hour period of inactivity and do not flush a sample site at the outlet before collection of the sample.
11. Leave all angle stops, shutoff valves, and similar devices on the sample line providing water to the drinking water location in a normal state of operation prior to sampling. Do not modify, open, or close any devices located on the sample line in preparation for collecting a sample. Doing so may cause sample results that are not representative of normal operating conditions.
12. Do not remove any filters, aerators, or screens at any sample outlet prior to collecting the samples.
13. All sample bottles must be labeled with the Sample IDs for each sample location. All samples must be collected in 1 liter wide mouth plastic bottles and all bottles must be completely filled. Make sure your laboratory provides 1 liter (not 250 mL) wide mouth sample bottles.
14. If a bottle does not fit at the sample site and cannot be completely filled, a spare 1 liter laboratory bottle may be used to partially fill and transfer the drinking water until the sample bottle is full.
15. It should be requested to the laboratory to provide unpreserved sample bottles. All samples must be delivered to the testing laboratory within 14 days of collection for preservation.
16. Cold water must be collected for all samples. If sampling from a drinking water outlet that provides cold and hot water, the cold water handle must be used for sample collection.

Initial Sampling

Initial sampling is used to determine if a drinking water outlet has a lead level that is above or below the Action Level of 15 ppb. Drinking water outlets with a test result of equal to or less than 15 ppb do not need additional testing and a water system is not required to collect additional samples when the initial sample results is less than or equal to 15 ppb. Drinking water outlets with an initial sampling test result of greater than 15 ppb exceed the Action Level and should undergo repeat sampling. Water system staff should provide the initial test results to the school contact person and meet with the school to discuss the results within 10 days of receipt from the laboratory. In the case of an Action Level exceedance water system staff should provide the results to the school within two school business days. Following a review of the initial test results the school should document how it will proceed with each individual drinking water outlet.

1. After completing the preparation steps above, the trained sampler collects initial samples using the Initial Sampling Instructions as guidance.
2. Upon delivery of the samples to the laboratory, the standard laboratory turn-around-time for receiving results is acceptable.
3. All initial sample locations with a test result of less than or equal to 15 ppb have lead levels less than the Action Level, the location is suitable for consumption, and no further testing is needed.
4. All initial sample locations with a test result of greater than 15 ppb have a lead level that exceeds the Action Level and should be tested again by collecting a repeat sample.

5. AB 746 requires after an Action Level is exceeded, the school “shall take immediate steps to make inoperable and shut down from use all fountains and faucets where the excess lead levels may exist.” If a school wishes to resample the initial sample location, the school should complete the sampling as soon as possible, post the fountain or faucet “do not use for drinking”, and continue to use the fountain or faucet for non-drinking purposes until the repeat sample is collected, maintain regular usage. Please see #11 above for additional sampling procedures.
6. Alternatively, drinking water locations with an initial Action Level exceedance can be removed from service permanently or until addressed using the EPA 3Ts recommendations for routine, interim, and permanent corrective actions.
7. Investigate whether other drinking water locations that were not tested but can be reasonably expected to have similar lead levels based on the age, material, location, and/or plumbing configuration and should be removed from service permanently or until addressed using the EPA 3Ts recommendations.
8. A drinking water location with an Action Level exceedance requires that a sample be collected at the service connection to the school to determine the lead level of water entering the school from the distribution system. The service connection sample location should be flushed before sampling (this sample is not a first draw sample) to ensure that the sample is representative of distribution system water quality.
9. The water system cannot release the initial lead sampling data to the public for 60 days following the receipt of the initial sampling results in accordance with the permit amendment.

Repeat and Confirmation Sampling

Repeat sampling is used to confirm an initial sampling result indicating that a drinking water outlet has a lead level that is greater than 15 ppb and exceeds the lead Action Level. Confirmation sampling is used to confirm the lead concentration at a drinking water location following an initial sampling lead result greater than 15 ppb and a repeat sampling lead result less than or equal to 15 ppb. Repeat sampling should be performed within 10 days of receiving the initial sample results and, if necessary, confirmation repeat sampling should be performed within 10 days of receiving the repeat sample results. Drinking water outlets with a repeat Action Level exceedance that confirms an initial sample result should be removed from service until corrective actions and check sampling have been performed with test results that indicate the water outlet has a lead level of less than 15 ppb. Water system staff should provide the repeat test results to the school contact person and meet with the school to discuss the results within 10 days of receipt from the laboratory and in the case of an Action Level exceedance provide the results to the school within two school business days. Following a review of the repeat test results the school should document how it will proceed with each individual drinking water outlet.

1. After completing the preparation steps above, the trained sampler collects repeat samples using the Repeat Sampling Instructions as guidance.
2. Upon delivery of the samples to the laboratory it shall be requested that results are reported by the laboratory within 10 business days.
3. All repeat sample locations with a test result of greater than 15 ppb have a lead level that exceeds the Action Level and should be removed from service permanently or addressed using the EPA 3Ts recommendations for routine, interim, and permanent corrective actions to minimize students and staff exposure to lead in drinking water.
4. All repeat sample locations with a test result of less than or equal to 15 ppb should be tested again by collecting a confirmation repeat sample to confirm the lead concentration at the drinking water outlet.
5. If the confirmation repeat sample has a test result of greater than 15 ppb the outlet has a lead level that exceeds the Action Level and should be removed from service

permanently or addressed using the EPA 3Ts recommendations for routine, interim, and permanent corrective actions and check sampling.

6. Investigate whether other drinking water locations that were not tested but can be reasonably expected to have similar lead levels based on the age, material, location, and/or plumbing configuration and should be removed from service permanently or until addressed using the EPA 3Ts recommendations.
7. A drinking water location with an Action Level exceedance requires that a sample be collected at the service connection to the school to determine the lead level of water entering the school from the distribution system. The service connection sample location should be flushed before sampling (this sample is not a first draw sample) to ensure that the sample is representative of distribution system water quality.
8. If the confirmation repeat sample has a test result of less than or equal to 15 ppb the lead level is less than the Action Level, the location is suitable for consumption, and no further testing is needed.
9. The water system is not required to collect any additional samples when the repeat result and confirmation repeat result are less than or equal to 15 ppb.
10. All repeat sample locations with an Action Level exceedance should remain out of service until the school has completed the corrective actions and the water system has completed check sampling identified in the Corrective Action Plan described below in the Laboratory Results section of this guidance document.

Corrective Action Check Sampling

Following the implementation of any corrective action at a drinking water outlet, check sampling should be performed to determine if the corrective action was successful in reducing the lead level to less than 15 ppb. Corrective actions are performed to reduce the lead concentration at a specific outlet; however, it is possible for a corrective action to have no effect or to increase the lead concentration at an outlet. If any check sample has a lead result of greater than the Action Level, additional corrective actions should be performed until the check sample indicates that the drinking water outlet has a lead level of less than 15 ppb. Water system staff should provide the corrective action test results to the school contact person and meet with the school to discuss the results within 10 days of receipt from the laboratory and in the case of an Action Level exceedance provide the results to the school within two school business days. The drinking water outlet should remain out of service during check sampling and until a lead level of less than 15 ppb is obtained for the test result.

The water system is not required to collect additional samples when the corrective action sample result is less than or equal to 15 ppb. If successive corrective actions indicate that the lead level at a drinking water outlet cannot be reduced to equal to or less than the Action Level, the school may choose to permanently remove the outlet from service. Water system staff should provide all laboratory test results to the school contact person upon receipt and in the case of an Action Level exceedance should provide the results within two school business days. Following a review of the check sampling test results the school should document how it will proceed with each individual drinking water outlet.

1. After completing the preparation steps above, the trained sampler collects check samples using the Corrective Action Check Sampling Instructions as guidance.
2. Upon delivery of the samples to the laboratory it shall be requested that results are reported by the laboratory within 10 business days.
3. All check samples with a test result of less than or equal to 15 ppb have lead levels less than the Action Level, no further testing at the drinking water outlet is needed, and the drinking water outlet can be placed back into service.
4. The water system is not required to collect additional samples when the corrective action sample result is less than or equal to 15 ppb.

5. All check samples with a test result of greater than 15 ppb have lead levels greater than the Action Level and additional corrective actions should be implemented at the drinking water outlet.
6. Following each corrective action, collect a check sample for testing to determine if the corrective action was successful in reducing the lead level at the drinking water outlet to less than 15 ppb.
7. Complete the necessary corrective actions and check sampling until a lead level of less than 15 ppb is obtained at which time the drinking water outlet can be placed back into service.

Laboratory Concentrations

The testing laboratory may report the results of the initial and repeat samples in several different formats or units. If the report includes the units of ppb (parts per billion) or ug/L (micrograms per liter) these two are essentially the same and the values in the report can be directly compared to the lead Action Level. If the report includes the units of ppm (parts per million) or mg/L (milligrams per liter) the values in the report must be converted to ppb or ug/L before comparison to the lead Action Level. To convert between units use the following conversion factors:

Convert from ppm to ppb: 1 ppm = 1,000 ppb
 Convert from mg/L to ug/L: 1 mg/L = 1,000 ug/L

For example, if the laboratory reports an initial sample result of 0.007 ppm, the conversion would be $0.007 \text{ ppm} \times 1,000 = 7 \text{ ppb}$. The drinking water outlet has a lead concentration below the Action Level of 15 ppb and no further testing is needed.

If the laboratory reports an initial sample result of 0.021 mg/L, the conversion would be $0.021 \text{ mg/L} \times 1,000 = 21 \text{ ug/L}$. Since the units of ug/L and ppb are essentially the same, the drinking water outlet has a lead concentration above the Action Level of 15 ppb and needs testing again using the Repeat Sampling Instructions.

Laboratory Results

Test results should be reviewed by both the water system and the school prior to making any decisions on Action Level exceedances, repeat, confirmation, and check sampling, corrective actions, and release of the results and testing information to the students, staff, and water system customers.

Under most conditions laboratory results are very accurate and considered final; however, under rare circumstances errors can occur during sampling or in the laboratory and test results may not reflect the true concentration of the drinking water outlet. If you feel this has happened, contact the water system staff who performed the sampling and let them know. Water system staff should contact the local SWRCB DDW office for instructions on how to proceed.

Following the review of initial test results by both the water system and the school, both parties should document which drinking water locations are below the Action Level and need no additional testing, and which drinking water locations are above the Action Level and need repeat testing.

Following review of repeat test results by both the water system and the school, both parties should document which drinking water locations have Action Level exceedances and require corrective actions.

Corrective Action Plan

It is recommended that the school prepare a Corrective Action Plan if initial sample test results exceed the Action Level. The water system may be able to assist. The Corrective Action Plan identifies all drinking water outlets that need corrective actions to bring lead levels to less than or equal to 15 ppb and check sampling to return the drinking water outlets to service. The Corrective Action Plan lists all corrective actions found to be appropriate for each individual drinking water location with an Action Level exceedance. Corrective actions such as an aerator/screen cleaning and maintenance program may be suitable for one drinking outlet while the complete replacement of the outlet may be suitable for another location. Schools should refer to the EPA 3Ts references for detailed information on corrective actions.

The Corrective Action Plan should be completed before releasing the results and testing information to the students, staff, and water system customers as it will help answer questions about Action Level Exceedances and what plans the school has to address the lead contamination issues. The Corrective Action Plan should be updated with the dates that corrective actions are made, the dates check sampling is performed, and the dates each drinking water outlet is returned to service, so that a record is maintained of each drinking water outlet initially having an Action Level exceedance.

Differences Between SWRCB and EPA Sample Collection

Schools are encouraged to read the EPA 3Ts references listed in the SWRCB *Frequently Asked Questions about Lead Sampling of Drinking Water in California Schools* document. SWRCB has prepared the lead testing at schools program using the EPA 3Ts documents, however, there are differences between the two sampling procedures. The table below lists the major differences and highlights the SWRCB procedures that should be followed.

Differences Between SWRCB and EPA Sample Collection				
Sampling Step	SWRCB Sampling Use These Procedures		EPA 3Ts Sampling (Not Used)	
Lead Action Level	15 ppb	If Initial Sample greater than 15 ppb should do repeat sample	20 ppb	If Initial Sample greater than 20 ppb should do follow-up sample
Initial Sample	1 liter	Tests for lead in the sample outlet and internal plumbing	250 mL	Tests for lead in the sample outlet
Repeat Sample	1 liter	Confirms Initial Sample Result	Not used	
Confirmation Repeat Sample	1 liter	Confirms Repeat Sample Result	Not used	
Corrective Action Check Sample	1 liter	Test lead level after implementation of corrective actions	Not used	
Follow-up Sample with 30-second flush	Not used		250 mL	Test for lead in the internal plumbing
Two-step sampling process	Not used		Determines if source of lead is from sample outlet or internal plumbing	

ATTACHMENT A13c

Lead Sampling Plan and Corrective Action Plan	Record water system and school information; record sample collection information noting any important observations during sampling; complete sample location map for all samples; document all routine, interim, and permanent corrective actions implemented		Not used	
Plumbing Profile and Sampling Plan	Not used		Prepare building and plumbing details; Select sites to be tested	
Drinking Outlet Inactivity	6 hours	Sample outlet unused for at least 6 hrs prior to sampling	8-18 hours	Sample outlet unused for at least 8 hrs but no more than 18 hrs prior to sampling

Summary of Repeat Monitoring At Each Sample Site

DDW AND CDE PRESS RELEASE CORRECTION: 2 DAY REPORTING OF RESULTS IS FOR ACTION LEVEL EXCEEDANCES ONLY (SEE BELOW)

Route	Initial Sample Collected within 90 days of request or per alternative sampling plan.	First Repeat Collected within 10 business days of receipt of Initial sample results	Second (Confirmation) Repeat Collected within 10 business days of receipt of First Repeat sample results	Corrective Action Sample Collect Corrective sample after any corrective action
1	Lead is less than or equal to 15 ppb. Monitoring is complete.	No action	No action	No action
2A	Lead is greater than 15 ppb AND the sample site remains in service. Proceed to first repeat.	First Repeat lead sample is greater than 15 ppb. Repeat monitoring is complete. Remove sample site from service.	No action	Corrective action lead sample is greater than 15 ppb. Continue with corrective actions. (School is responsible for additional samples.) OR Corrective action lead sample is less than or equal to 15 ppb. Monitoring is complete.
2B1	Lead is greater than 15 ppb AND the sample site remains in service. Proceed to first repeat.	First Repeat lead sample is less than or equal to 15 ppb. Collect second repeat sample	Second Repeat lead sample is greater than 15 ppb. Repeat monitoring is complete. Remove sample site from service.	Corrective action lead sample is less than or equal to 15 ppb. Monitoring is complete.
2B2	Lead is greater than 15 ppb AND the sample site remains in service. Proceed to first repeat.	First Repeat lead sample is less than or equal to 15 ppb. Collect second repeat sample	Second Repeat lead sample is less than or equal to 15 ppb. Repeat monitoring is complete.	No action
3	Lead is greater than 15 ppb AND the school removes the sample site from service within 10 business days of the receipt of the sample analysis.	No action	No action	No action

Time Requirements for Reporting Results

- Within 90 days following receipt of a written request for sampling from a school, the water system must either 1) finalize a sampling plan with the school and complete initial sampling, or 2) develop an alternative schedule with the school for preparation of the sampling plan and completing sample collection. An alternative plan must be submitted to DDW for approval within 90 days of receipt of the written request.
- The water system must provide and discuss the sample results (initial, first repeat, second repeat, and corrective action) with the school within 10 days of receipt of the sample results from the testing laboratory, and within 2 business days of receipt when the sample results include an Action Level exceedance.
- First repeat samples must be collected within 10 business days of receipt of the initial sample results; second repeat samples must be collected within 10 business days of receipt of the first repeat results. At least one Corrective Action sample should be collected immediately following installation of the corrective action.
- The water system should request to the laboratory that testing and reporting for all repeat samples be completed in 10 days.
- The water system must not release the sampling results to the public for 60 days following the receipt of the initial sample results unless the water system releases the data in compliance with a Public Records Act (PRA) request for the specific results.
- All lead sample results should be reported electronically by EDT to DDW using the School Lead Sampling and Reporting Tool at <https://drinc.ca.gov/lsics/> It is recommended but not required that a public water system notify DDW of an action level exceedance at the same time they notify the school (via email to DDW-PLU@waterboards.ca.gov).