

PRE-CHECK (PC) PERMANENT MODULAR OR RELOCATABLE BUILDING DESIGNS CALGREEN/ENERGY CODE COMPLIANCE REVIEW

PURPOSE: This Procedure (PR) outlines the requirements for the California Green Building Standards Code (CALGreen Code) and the California Energy Code (CEC, Energy Code) compliance review of pre-check (PC) permanent or modular or relocatable building designs submitted to the Division of the State Architect (DSA) for approval. This PR details how a building design, which will be placed on various sites, is required to meet the requirements of the current version of the CALGreen Code and Energy Code.

BACKGROUND: All public school facility construction within the State of California must comply with all Parts of Title 24, California Building Standards Code, including the energy efficiency standards contained in Title 24, Part 6, Energy Code and the mandatory measures contained in Title 24, Part 11, CALGreen Code.

SCOPE: This PR is applicable to the CALGreen Code and Energy Code compliance for PC permanent or modular or relocatable building designs. See DSA Procedure [PR 07-01: Pre-Check Approval Process](#) for general requirements for PC designs.

PC designs subject to CALGreen/Energy Code compliance review:

- CALGreen Code: New permanent modular or relocatable buildings.
- Energy Code: New conditioned or unconditioned permanent modular or relocatable buildings. Refer to Table 100.0-A Application of Standards of the current version of the Energy Code.

1. PROCESS FOR PLAN REVIEW OF CALGREEN/ENERGY CODE COMPLIANCE:

1.1 For the intake review, the applicant shall electronically submit documents via DSA's cloud repository, DSAbbox, in the DSA Review, CALGreen Plan Review folder. A complete submittal for all projects, at a minimum, consists of:

- a) A signed and completed form [DSA 403-PC: 2016 CALGreen and Energy Code–Compliance Checklist for Pre-Checked \(PC\) Permanent Modular or Relocatable Building Designs](#).
- b) Construction documents showing all required CALGreen Code and Energy Code requirements.
- c) Construction or material specifications associated with the construction documents.
- d) Applicable Energy Code Certificates of Compliance in PDF format.

In addition, if the project contains conditioned buildings, the following information must be provided for a complete submittal:

- e) Energy Code Commissioning Forms in PDF format.
- f) Performance Runs and Orientation Tables (PDF) for the smallest (or only) building in the project for the climate zones in which the building may be sited (see Section 3.2 and Attachment 1).
- g) Performance Runs and Orientation Tables (PDF) for the largest building in the project (if applicable) for the climate zones in which the building may be sited (see Section 3.2 and Attachment 1).
- h) For the smallest (or only) building in the project, submit for each climate zone the Building Energy Analysis Report (PDF) showing the least compliance margin .
- i) For the largest building in the project (if applicable), submit for each climate zone the Building Energy Analysis Report (PDF) showing the least compliance margin.
- j) Cut sheets of HVAC equipment.

**PRE-CHECK (PC) PERMANENT MODULAR OR RELOCATABLE BUILDING DESIGNS
CALGREEN/ENERGY CODE COMPLIANCE REVIEW**

- 1.2 If the project contains conditioned buildings with multiple options, a complete submittal will also include the applicable Building Energy Analysis Reports to demonstrate compliance, in accordance with the guidance in Section 3.6 of this document.
- 1.3 Software files of the energy reports are required only if requested.
- 1.4 **Fees:** See PR 07-01 for the filing fee requirements.
- 1.5 Documents submitted for Energy Code and CALGreen Code review will be reviewed for the required elements indicated on the DSA 403-PC to determine that the required information has been submitted. Plan review will not commence until all required information is provided. The applicant will be notified of any deficient information.
- 1.6 At time of backcheck, a complete set of construction documents shall be submitted. The final project submittal documentation shall include, *in a legible font size*, the following approved energy report documentation placed on a plan sheet in the construction documents:
- Revised Performance Runs and Orientation Tables modeling changes in the building attributed to plan review corrections (see Attachment 1).
 - One final Building Energy Analysis Report (Certificate of Compliance NRCC-PRF-01-E) corresponding to the revised Performance Runs and Orientation Tables and demonstrative of the building with the *least energy efficient orientation* for the project. (see Attachment 1). The least compliance margin is the least energy efficient orientation.
- 1.7 **DSA/HPS Approval Stamp:** Submit electronically a complete plan set to the plan reviewer for an approval stamp and signature a minimum of two weeks prior to the backcheck appointment with the structural lead engineer.
- 1.8 **Revisions to the PC Design After Approval:** The buildings constructed from the approved plan set are limited to the options for HVAC equipment, insulating properties of the building envelope, and size and location of openings in the building envelope specified in the documents. No changes are permitted to the buildings that are less restrictive than that which has been demonstrated for Energy Code compliance in the approved drawings and Building Energy Analysis Reports. For site-specific application, if modifications to the building that affect Energy Code compliance are desired, revised Building Energy Analysis Reports shall be submitted to DSA at the time of the site submittal approval appointment. If the manufacturer desires to revise the approved PC plans for all future submittals, the plans and revised Building Energy Analysis Reports must be submitted to DSA for approval under the original PC application number.
2. **CALGREEN CODE COMPLIANCE DOCUMENTATION REQUIREMENTS:**
- 2.1 **Reference Documents:** DSA Guideline [GL-4: Project Submittal Guideline: CALGreen Code](#) and PART 2 of the DSA 403-PC.
- 2.2 **CALGreen Code, Chapter 5.2 through 5.5:** Incorporate the mandatory measures for the project in the drawings and specifications as indicated on PART 2 of the form DSA 403-PC.
3. **ENERGY CODE COMPLIANCE DOCUMENTATION REQUIREMENTS:**
- 3.1 **Reference Document:** Current version of the Energy Code, Non-Residential (NR) Joint Appendix NA4, and Appendix JA2, Table 2-1 for reference cities and PART 1 of the DSA 403-PC.
- 3.2 **Energy Code Mandatory Measures:** Incorporate the mandatory measures for the project in the drawings and specifications. See Attachment 3.
- 3.3 **Performance Runs and Orientations:** Energy performance runs shall address minimum compliance of the modeled building based on the following orientations: 30°, 75°, 120°, 165°, 210°, 255°, 300°, and 345°. For each climate zone in which the building may be sited, submit in a tabular form the compliance results of the performance runs indicating the orientation, the Time Dependent Value (TDV) of the

**PRE-CHECK (PC) PERMANENT MODULAR OR RELOCATABLE BUILDING DESIGNS
CALGREEN/ENERGY CODE COMPLIANCE REVIEW**

standard design, the TDV of the proposed design, and the compliance margin the proposed design exceeds the energy efficiency of the standard design (see Attachment 1).

- 3.4 California Climate Zones:** The climate zone(s) for which the building has been designed shall be noted on the cover sheet of the construction documents.
- California Climate Zones 1-13: Any PC building design that complies with the *least energy efficient orientation* in California Climate Zones 1-13 shall be approved for placement only within the designed climate zone(s).
 - California Climate Zones 14, 15 and 16: The permanent or relocatable modular building with the *least energy efficient orientation* in California Climate Zones 14, 15 and 16 is permitted to be built on any site in California.
- 3.5 Run Codes (Calculation Date/Time):** Run codes identify the time when the energy report was calculated and is unique to each revision made to an energy model. The “calculation date/time” can be found on the California Energy Commission’s Certificate of Compliance NRCC-PRF-01-E. The final approved Building Energy Analysis Report to be placed on the drawings must match final approved reports.
- 3.6 Permanent or Relocatable Modular Buildings with Multiple Options:** (Refer to PR 07-01, Appendix A for guidelines for multiple-options in a single PC.) The following energy modeling guidelines will be used for the following options:
- Expandable building floor plan: Model the floor plans with the smallest square footage and the largest square footage.
 - Optional window locations: Model the building envelope with the greatest area of windows, doors, and skylight openings.
 - Roof assembly with variations for the roofing material: Model the roof assembly that will give the least compliance margin.
 - Different occupancies: Model the occupancy type that will give the least compliance margin.
 - Variations in type of Heating Ventilation and Air Conditioning (HVAC) system: Model the HVAC system that will result in the least compliance margin.
- 3.7 Outdoor Ventilation Requirements:** Building Energy Analysis Reports shall be designed according to the following requirements for HVAC systems:
- For all spaces, the outdoor air-ventilation rate and air-distribution assumptions made in the design of the ventilating system shall be clearly identified on the plans.
 - Spaces shall be designed with outdoor ventilation requirements supplied by mechanical means in accordance with CEC Section 120.1.(b)2. Minimum outdoor air for classrooms shall be 0.38 cfm per SF. If the HVAC system for classrooms is designed to meet only the minimum requirements under the CEC, and does not contain an economizer and demand control ventilation devices, the following note must be included in the plans:
 - “Per the California Energy Code (CEC), classrooms are designed for minimum outside air of 0.38 cfm per SF or to 15 cfm per occupant, whichever is greater. PC manufacturer shall verify with the school district the expected number of occupants in the classroom so that the outdoor ventilation rate for mechanical systems can be adequately adjusted upon site installation of the building. PC manufacturer shall also confirm with HVAC equipment manufacturer that the selected equipment will be able to perform to accommodate the additional outdoor air requirements under peak design conditions for the climate zone in which the building is located. At occupancy, the building manufacturer shall provide to building owner a description of the quantities of outdoor and recirculated air that the ventilation systems are designed to provide to each area.”

**PRE-CHECK (PC) PERMANENT MODULAR OR RELOCATABLE BUILDING DESIGNS
CALGREEN/ENERGY CODE COMPLIANCE REVIEW**

3.8 Solar Ready Requirements: Refer to Title 24, Part 6, Section 110.10. For permanent or relocatable modular building with roof slopes of 2:12 or higher, provide a solar zone diagram on plans showing the solar zone orientation requirements for future installation of solar/photovoltaic panels. Illustrate the solar zone on all roof plans in compliance with California Fire Code Section 605.11 (see Attachment 2).

3.9 Operating and maintenance information to be provided by building manufacturer: The following note shall be provided on the cover sheet of the plans:

“Building manufacturer shall leave for the building owner at occupancy operating information for all applicable mechanical and electrical features, materials, components and devices installed in the building related to efficient energy use. In addition, the building manufacturer shall leave maintenance information for all features, materials, components, and manufactured devices that require routine maintenance for efficient operation of mechanical equipment and lighting systems.”

REFERENCES:

California Code of Regulations (CCR) Title 24

Part 11: Current version of the CALGreen Code

Part 6: Current version of the Energy Code

DSA web page: [Energy Efficiency Regulations and Plan Review for School Construction](#)

A Division of the State Architect (DSA) Procedure documents a process or series of steps that DSA staff and/or external stakeholders must complete in order to fulfill one or more administrative requirements of DSA's plan and construction review programs.

**PRE-CHECK (PC) PERMANENT MODULAR OR RELOCATABLE BUILDING DESIGNS
CALGREEN/ENERGY CODE COMPLIANCE REVIEW**

ATTACHMENT 1: Sample Performance Runs and Orientation Table

Provide the compliance margins for all orientations and highlight the least compliance margin for each climate zone. This table is not generated by the energy software.

PC DESIGN REVIEW INFORMATION				
Title 24, Part 6, Energy Code				
DSA Application #:				
Calculation Date/Time of Energy Report:				
Model Name and Option:				
Total Floor Area:				
HVAC System Type:				
Climate Zone (Reference City)	Azimuth (Front Orientation)	TDV - Standard Design	TDV – Proposed Design	Compliance Margin
14 (Palmdale)	30	257.82	233.46	9.4
	75	261.14	235.35	9.9
	120	259.99	234.10	10.0
	165	255.30	231.32	9.4
	210	259.54	233.97	9.4
	255	236.94	236.48	10.4
	300	261.29	235.16	10.0
	345	251.70	231.75	7.9
15 (Palm Springs-Intl)	30	236.54	208.71	11.8
	75	239.98	210.81	12.2
	120	240.02	209.79	12.6
	165	232.26	206.84	10.9
	210	237.05	209.26	11.7
	255	243.07	211.73	12.9
	300	242.88	210.55	13.3
	345	233.05	207.02	11.2
16 (Blue Canyon)	30	292.72	255.26	12.8
	75	297.24	258.17	13.1
	120	296.13	257.14	13.2
	165	288.26	253.01	12.2*
	210	294.87	255.86	13.2
	255	300.46	259.25	13.7
	300	299.06	257.98	13.7
	345	288.52	253.24	12.2*

Reference: Energy Code, Appendix NA4, Table NA4-3

Notes:

*In the event that there are identical compliance margins, select one.

**PRE-CHECK (PC) PERMANENT MODULAR OR RELOCATABLE BUILDING DESIGNS
CALGREEN/ENERGY CODE COMPLIANCE REVIEW**

ATTACHMENT 2: Illustration of Solar Ready Requirements

Suggested detail to be affixed to construction documents for buildings with roofs sloped greater than 2:12 to meet the solar ready requirements of Title 24, Part 6, Section 110.10

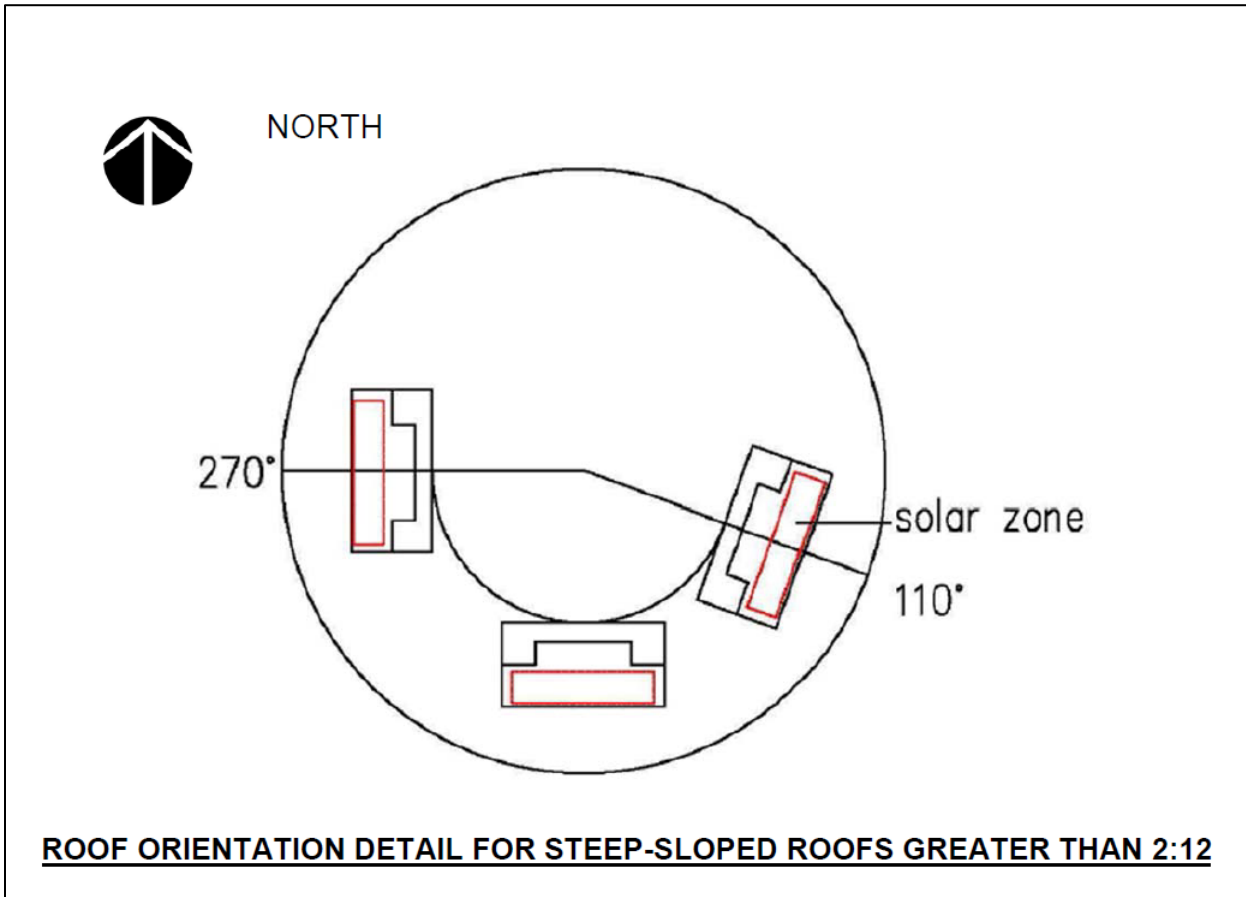

**PRE-CHECK (PC) PERMANENT MODULAR OR RELOCATABLE BUILDING DESIGNS
CALGREEN/ENERGY CODE COMPLIANCE REVIEW**

ATTACHMENT 3: Nonresidential Mandatory Measures

Note: According to the 2016 Energy Code, the Nonresidential Mandatory Measures are required to be included in the construction documents. The following represents the mandatory measures typical to the designs for permanent modular and relocatable building designs submitted for Energy Code approval to the Division of the State Architect, and are offered as a guide for meeting Energy Code compliance. The systems as designed by the Designer of Record for a particular project may not be typical, may require additional mandatory measures, or may require the substitution of requirements applicable to the system as designed. The Designer of Record is responsible for the editing and the addition of the Nonresidential Mandatory Measures indicated below that are representative to the design of the building.

2016 CALIFORNIA ENERGY CODE (Title 24, Part 6, Chapter 1) NONRESIDENTIAL MANDATORY MEASURES
SPACE CONDITIONING
<p>§110.2 CERTIFICATION BY MANUFACTURERS ANY SPACE-CONDITIONING EQUIPMENT MAY BE INSTALLED ONLY IF THE MANUFACTURER HAS CERTIFIED TO THE CALIFORNIA ENERGY COMMISSION THAT THE EQUIPMENT COMPLIES WITH ALL THE APPLICABLE REQUIREMENTS OF CEC SECTION 110.2(A).</p>
<p>§120.1 VENTILATION REQUIREMENTS §120.1(a)1 ALL ENCLOSED SPACES IN A BUILDING SHALL BE VENTILATED IN ACCORDANCE WITH THE REQUIREMENTS OF THE CALIFORNIA BUILDING CODE. §120.1(a)2 THE OUTDOOR AIR-VENTILATION RATE AND AIR-DISTRIBUTION ASSUMPTIONS MADE IN THE DESIGN OF THE VENTILATING SYSTEM SHALL BE CLEARLY IDENTIFIED ON THE PLANS. §120.1(b) SPACES SHALL BE DESIGNED WITH OUTDOOR VENTILATION REQUIREMENTS SUPPLIED BY MECHANICAL MEANS. MINIMUM OUTDOOR AIR FOR CLASSROOMS SHALL BE 0.38 CFM PER SF OR 15CFM PER OCCUPANT, WHICHEVER IS GREATER.</p>
<p>§120.2(e)3 REQUIRED OCCUPANT SENSOR VENTILATION CONTROLS IN CLASSROOMS §120.1(c)5 OCCUPANT SENSORS SHALL BE USED TO REDUCE THE RATE OF OUTDOOR AIR FLOW WHEN OCCUPANTS ARE NOT PRESENTS IN ACCORDANCE WITH THE FOLLOWING: §120.1(c)5A OCCUPANT SENSORS SHALL MEET THE REQUIREMENTS OF SECTION 110.9(b)4 AND SHALL HAVE SUITABLE COVERAGE AND PLACEMENT TO DETECT OCCUPANTS IN THE ENIRE SPACE VENTILATED. OCCUPANT SENSORS CONTROLLING LIGHTING MAY BE USED FOR VENTILATION AS LONG AS THE VENTILATION SIGNAL IS INDEPENDENT OF DAYLIGHTING, MANUAL LIGHTING OVERRIDES, OR MANUAL CONTROL OF LIGHTING. WHEN A SINGLE ZONE DAMPER OR A SINGLE ZONE SYSTEM SERVES MULTIPLE ROOMS, THERE SHALL BE AN OCCUPANCY SENSOR IN EACH ROOM AND THE ZONE IS NOT CONSIDERED VACANT UNTIL ALL ROOMS IN THE ZONE ARE VACANT. §120.1(c)5B ONE HOUR PRIOR TO NORMAL SCHEDULED OCCUPANCY, THE OCCUPANCY SENSOR SHALL ALLOW PRE-OCCUPANCY PURGE. §120.1(c)5D WITHIN 30 MINUTES AFTER BEING VACANT FOR ALL ROOMS SERVED BY A SINGLE ZONE SYSTEM, THE SINGLE ZONE SYSTEM SHALL CYCLE OFF THE SUPPLY FAN WHEN THE SPACE TEMPERATURE IS BETWEEN THE HEATING AND COOLING SETPOINTS. §120.1(c)5E WHEN VACANT DURING HOURS OF EXPECTED OCCUPANCY AND THE OCCUPIED VENTILATION RATE IS NOT PROVIDED, THEN THE SYSTEM SHALL CYCLE OR OPERATE TO MAINTAIN THE AVERAGE OUTDOOR AIR RATE OVER AN AVERAGING PERIOD OF 120 MINUTES EQUAL TO 25% OF 0.15 CFM PER SQUARE FOOT OF CONDITIONED FLOOR AREA. EXCEPTION TO 120.1(c)5 IF DEMAND CONTROL VENTILATION IS IMPLEMENTED</p>
<p>§120.4 REQUIREMENTS FOR AIR DISTRIBUTION SYSTEM DUCTS AND PLENUMS §120.4(a) SUPPLY AIR AND RETURN AIR DUCTS CONVEYING HEATED OR COOLED AIR LOCATED OUTDOORS OR IN UNCONDITIONED SPACES SHALL BE INSULATED MINIMUM INSTALLED LEVEL OF R-8. PORTIONS OF SUPPLY-AIR DUCTS THAT ARE NOT LOCATED IN THESE SPACES SHALL BE INSULATED TO A MINIMUM INSTALLED LEVEL OF R-4.2 OR BE ENCLOSED IN DIRECTLY CONDITIONED SPACE.</p>
<p>§120.5 REQUIRED NONRESIDENTIAL SYSTEM ACCEPTANCE THE FOLLOWING EQUIPMENT AND SYSTEMS SHALL BE CERTIFIED AS MEETING THE ACCEPTANCE REQUIREMENTS FOR CODE COMPLIANCE AS SPECIFIED BY REFERENCE NONRESIDENTIAL APPENDIX NA7: 1. OUTDOOR AIR VENTILATION SYSTEMS 2. CONSTANT VOLUME SINGLE ZONE UNITARY AIR CONDITIONING AND HEAT PUMP UNIT CONTROLS</p>

**PRE-CHECK (PC) PERMANENT MODULAR OR RELOCATABLE BUILDING DESIGNS
CALGREEN/ENERGY CODE COMPLIANCE REVIEW**

2016 CALIFORNIA ENERGY CODE (Title 24, Part 6, Chapter 1) NONRESIDENTIAL MANDATORY MEASURES
ENVELOPE
<p>§110.6(a) MANUFACTURED WINDOW AND EXTERIOR DOOR AIR LEAKAGE §110.6(a)1 MANUFACTURED WINDOWS AND EXTERIOR DOORS SHALL HAVE AIR INFILTRATION RATES CERTIFIED BY THE MANUFACTURER NOT EXCEEDING 0.3 CFM/FT² OF WINDOW AREA, 0.3 CFM/FT² OF DOOR AREA FOR NONRESIDENTIAL SINGLE DOORS (SWINGING AND SLIDING), AND 1.0 CFM/FT² FOR NONRESIDENTIAL DOUBLE DOORS (SWINGING), WHEN TESTED ACCORDING TO NFRC-400 OR ASTM E283 AT A PRESSURE DIFFERENTIAL OF 75 PASCALS.</p>
<p>§110.6(a)2-5 MANUFACTURED WINDOW RATING AND LABELING ALL MANUFACTURED WINDOWS SHALL BE RATED FOR U-FACTOR AND SHGC ACCORDING TO NFRC PROCEDURES, OR USE THE DEFAULT VALUES PER TABLE 110.6-A FOR U-FACTOR AND TABLE 110.6-B FOR SHGC. ALL WINDOWS SHALL BE RATED FOR VT ACCORDING TO NFRC PROCEDURES. ALL MANUFACTURED WINDOWS SHALL BE LABELED ACCORDING TO §110.6(a)5.</p>
<p>§110.7 EXTERIOR JOINTS ALL EXTERIOR JOINTS, PENETRATIONS, AND OPENINGS IN THE BUILDING ENVELOPE THAT ARE POTENTIAL SOURCES OF AIR LEAKAGE SHALL BE CAULKED, GASKETED, WEATHER-STRIPPED, OR OTHERWISE SEALED.</p>
<p>§110.8(a) INSULATION CERTIFICATION INSTALLED INSULATION SHALL BE CERTIFIED BY THE DEPARTMENT OF CONSUMER AFFAIRS PER TITLE 24, PART 12, CHAPTERS 12-13, ARTICLE 3 "STANDARDS FOR INSULATING MATERIAL."</p>
<p>§110.8(b) UREA FORMALDEHYDE INSULATION UREA FORMALDEHYDE INSULATION SHALL NOT BE INSTALLED UNLESS IN EXTERIOR SIDE WALLS WITH A FOUR-MIL-THICK PLASTIC POLYETHYLENE VAPOR RETARDER OR EQUIVALENT PLASTIC SHEATHING VAPOR RETARDER IS INSTALLED BETWEEN THE UREA FORMALDEHYDE FOAM INSULATION AND THE INTERIOR SPACE.</p>
<p>§110.8(c) INSULATING MATERIAL ALL INSULATING MATERIALS SHALL BE INSTALLED IN COMPLIANCE WITH THE FLAME SPREAD RATING AND SMOKE DENSITY REQUIREMENTS OF THE CALIFORNIA BUILDING CODE.</p>
<p>§110.8(i) RATED ROOFING PRODUCTS ANY ROOFING PRODUCTS SPECIFIED TO MEET AGED SOLAR REFLECTANCE AND THERMAL EMITTANCE REQUIREMENTS SHALL BE CERTIFIED AND LABELED BY THE COOL ROOF RATING COUNCIL (CRRC), OR USE DEFAULT VALUES: ASPHALT SHINGLES: 0.08/0.75, ALL OTHERS: 0.10/0.75</p>
<p>§120.7(a) ROOF/CEILING INSULATION (REFERENCE JOINT APPENDIX JA4) WEIGHTED AVERAGE U-FACTOR OF ROOF ASSEMBLY SHALL BE: ≤ 0.098 FOR METAL BUILDING ≤ 0.075 FOR WOOD FRAMED AND OTHER TYPES INSULATION PLACEMENT SHALL BE PER §120.7(a)3 REQUIREMENTS.</p>
<p>§120.7(b)1-6 WALL INSULATION (REFERENCE JOINT APPENDIX JA4) OPAQUE PORTIONS OF WALLS SEPARATING CONDITIONED SPACE FROM UNCONDITIONED/ AMBIENT SPACES SHALL MEET THE FOLLOWING: METAL BUILDING: WEIGHTED AVERAGE U-FACTOR OF WALL ASSEMBLY ≤ 0.113 METAL FRAMED: WEIGHTED AVERAGE U-FACTOR OF WALL ASSEMBLY ≤ 0.151 WOOD FRAMED AND OTHER TYPES: WEIGHTED AVERAGE U-FACTOR OF WALL ASSEMBLY ≤ 0.110</p>
<p>§120.7(c) FLOOR/SOFFIT INSULATION (REFERENCE JOINT APPENDIX JA4) OPAQUE PORTIONS OF FLOORS & SOFFITS SEPARATING CONDITIONED SPACE FROM UNCONDITIONED/AMBIENT SPACES SHALL MEET THE FOLLOWING (AS APPLICABLE): RAISED MASS FLOORS: SHALL HAVE MINIMUM OF 3" OF LIGHTWEIGHT CONCRETE OVER A METAL DECK, OR WEIGHTED U-FACTOR OF FLOOR ASSEMBLY ≤ 0.269 OTHER FLOORS: WEIGHTED U-FACTOR OF FLOOR ASSEMBLY ≤ 0.071</p>

**PRE-CHECK (PC) PERMANENT MODULAR OR RELOCATABLE BUILDING DESIGNS
CALGREEN/ENERGY CODE COMPLIANCE REVIEW**

2016 CALIFORNIA ENERGY CODE (Title 24, Part 6, Chapter 1) NONRESIDENTIAL MANDATORY MEASURES
INDOOR LIGHTING
<p>§110.9 LIGHTING CONTROLS AND COMPONENTS ALL LIGHTING CONTROL DEVICES AND SYSTEMS, BALLASTS, AND LUMINAIRES SHALL MEET THE APPLICABLE REQUIREMENTS OF §110.9.</p>
<p>§130.0 GENERAL LUMINAIRE REQUIREMENTS (INDOOR) ALL LUMINAIRES SHALL BE FACTORY-LABELED PER §130.0(c).</p>
<p>§130.1(a) INDIVIDUAL ROOM/AREA CONTROLS EACH ROOM AND AREA WITH FLOOR-TO-CEILING WALLS IN THIS BUILDING SHALL BE EQUIPPED WITH MANUAL ON AND OFF LIGHTING CONTROLS. CONTROLS MUST BE READILY ACCESSIBLE.</p>
<p>§130.1(b) MULTI-LEVEL LIGHTING CONTROLS ALL ROOMS AND AREAS 100 SF OR GREATER AND MORE THAN 0.5 WATT PER SF OF LIGHTING LOAD WITH 2 OR MORE LUMINAIRES SHALL BE CONTROLLED WITH MULTI-LEVEL SWITCHING FOR UNIFORM REDUCTION OF LIGHTING WITHIN THE ROOM. CONTROL STEPS TO MEET REQUIREMENTS IN TABLE 130.1-A. EXCEPTION: CLASSROOMS WITH A LIGHTING LOAD OF 0.7 W/SF OR LESS AND PUBLIC RESTROOMS SHALL HAVE ONE CONTROL STEP BETWEEN 30-70% OF FULL RATED POWER.</p>
<p>§130.1(c)5 REQUIRED USE OF OCCUPANT SENSORS WHEN MULTI-LEVEL CONTROL IS REQUIRED PER 130.1(b) (ENCLOSED AREA ≥ 100 SF AND LIGHTING LOAD > 0.5 W/SF) PROVIDE VACANCY SENSOR OR PARTIAL-ON OCCUPANCY SENSOR. WHEN MULTI-LEVEL CONTROL IS NOT REQUIRED PER 130.1(b), PROVIDE OCCUPANT SENSOR, PARTIAL-ON OCCUPANT SENSOR, OR VACANCY SENSOR IN THE FOLLOWING SPACES:</p> <ul style="list-style-type: none"> • OFFICES 250 SF OR SMALLER • MULTIPURPOSE ROOMS < 1,000 SF • CLASSROOMS OF ANY SIZE • CONFERENCE ROOMS OF ANY SIZE
<p>§130.1(c)6 PARTIAL OR FULL-OFF OCCUPANT SENSORS PROVIDE PARTIAL OR FULL-OFF OCCUPANT SENSORS, IN ADDITION TO SHUT-OFF CONTROLS PER §130.1(c)1 AND §130.1(c)2, IN THE FOLLOWING SPACES:</p> <ul style="list-style-type: none"> • LIBRARY BOOK STACK AISLES • CORRIDORS AND STAIRWELLS
<p>§130.1(d) AUTOMATIC DAYLIGHTING CONTROLS ALL DAYLIT ZONES MUST BE SHOWN ON THE PLANS. ALL GENERAL LIGHTING IN PRIMARY SIDELIT DAYLIT ZONES AND SKYLIT DAYLIT ZONES IN ENCLOSED SPACES WITH 120 WATTS, OR MORE IN COMBINED PRIMARY/SKYLIT ZONES AND 24 SF, OR MORE OF FENESTRATION SHALL BE CONTROLLED BY AUTOMATIC DAYLIGHT CONTROLS LOCATED IN THE DAYLIT ZONE.</p>
OUTDOOR LIGHTING
<p>§110.9 OUTDOOR LIGHTING CONTROLS AND COMPONENTS ALL LIGHTING CONTROL DEVICES AND SYSTEMS, BALLASTS, AND LUMINAIRES SHALL MEET THE APPLICABLE REQUIREMENTS OF §110.9.</p>
<p>§130.0 GENERAL LUMINAIRE REQUIREMENTS (OUTDOOR) ALL LUMINAIRES SHALL BE FACTORY-LABELED PER §130.0(c).</p>
<p>§130.2(a) INCANDESCENT LIGHTING ALL OUTDOOR LUMINAIRES WHICH CAN ACCEPT INCANDESCENT BULBS, AND WITH A MAXIMUM RATED WATTAGE (FOR ALL BULBS COMBINED) > 100 WATTS, SHALL BE CONTROLLED BY MOTION SENSOR.</p>
<p>§130.2(b) LUMINAIRE CUTOFF REQUIREMENTS ALL OUTDOOR LUMINAIRES THAT USE LAMPS RATED GREATER THAN 150 WATTS SHALL COMPLY WITH THE UPLIGHT REQUIREMENTS OF TABLE 130.2-A, AND THE GLARE REQUIREMENTS OF TABLE 130.2-B. EXCEPTION 3 TO §130.2(b): LIGHTING NOT PERMITTED BY HEALTH/LIFE SAFETY STATUTE, ORDINANCE OR REGULATION TO BE A CUTOFF LUMINAIRE.</p>

**PRE-CHECK (PC) PERMANENT MODULAR OR RELOCATABLE BUILDING DESIGNS
CALGREEN/ENERGY CODE COMPLIANCE REVIEW**

§130.2(c) CONTROLS FOR OUTDOOR LIGHTING

ALL OUTDOOR LIGHTING SHALL BE OPERATED WITH CONTROLS HAVING THE FOLLOWING FEATURES:

- AUTOMATICALLY TURNS OFF OUTDOOR LIGHTING WHEN DAYLIGHT IS AVAILABLE
- INDEPENDENTLY CONTROLLED FROM OTHER ELECTRICAL LOADS BY AN AUTOMATIC SCHEDULING CONTROL
- BUILDING FACADE, ORNAMENTAL HARDSCAPE AND OUTDOOR DINING LUMINAIRES SHALL MEET AT LEAST ONE OF THE FOLLOWING:
 - A PART-NIGHT OUTDOOR LIGHTING CONTROL
 - AUTO-ON MOTION SENSORS THAT REDUCE LIGHTING POWER BY AT LEAST 40% BUT NO MORE THAN 90%
 - OUTDOOR WALL MOUNTED LUMINAIRES (WALL PACKS) WHERE BOTTOM OF LUMINAIRE IS MOUNTED ≤ 24 FEET ABOVE THE GROUND SHALL COMPLY WITH §130.2(c)3

EXCEPTION 1 TO §130.2(c): LIGHTING NOT PERMITTED BY HEALTH/LIFE SAFETY STATUTE, ORDINANCE OR REGULATION TO BE TURNED OFF.

**2016 CALIFORNIA ENERGY CODE (Title 24, Part 6, Chapter 1)
NONRESIDENTIAL MANDATORY MEASURES**

SOLAR READY

§110.10(b)1B SOLAR READY BUILDINGS

THE MINIMUM SOLAR ZONE AREA SHALL BE SIZED ACCORDING TO §110.10(b)1B. CONSTRUCTION DOCUMENTS SHALL INDICATE LOCATIONS OF INVERTERS AND METERING EQUIPMENT AND PATHWAY FOR CONDUIT ROUTING FROM SOLAR ZONE TO POINT OF CONNECTION WITH ELECTRICAL SERVICE, OR PATHWAY FOR ROUTING OF PLUMBING FROM SOLAR ZONE TO WATER-HEATING SYSTEM.

EXCEPTION 3 TO §110.10(b)1B DESIGNATED SOLAR ZONE AREA NO LESS THAN 50% OF THE POTENTIAL SOLAR ZONE AREA (AS CALCULATED PER EXCEPTION).

§110.10(b)3 SHADING

NO OBSTRUCTIONS SHALL BE LOCATED IN THE SOLAR ZONE AND OBSTRUCTIONS LOCATED ON ANY PART OF THE BUILDING THAT PROJECTS ABOVE A SOLAR ZONE SHALL BE LOCATED AT LEAST TWICE THE DISTANCE (MEASURED IN THE HORIZONTAL PLANE) OF THE HEIGHT DIFFERENCE BETWEEN THE HIGHEST POINT OF THE OBSTRUCTION AND THE HORIZONTAL PROJECTION OF THE NEAREST POINT OF THE SOLAR ZONE (MEASURED IN THE VERTICAL PLANE).

EXCEPTION: ANY ROOF OBSTRUCTION (LOCATED ANYWHERE ON BUILDING) THAT IS ORIENTED NORTH OF ALL POINTS ON THE SOLAR ZONE

§110.10(b)4 STRUCTURAL DESIGN LOADS ON CONSTRUCTION DOCUMENTS

CONSTRUCTION DOCUMENTS SHALL INDICATE STRUCTURAL DESIGN LOADS FOR ROOF DEAD LOAD AND ROOF LIVE LOAD FOR AREAS OF THE ROOF DESIGNATED AS SOLAR ZONE.

**2016 CALIFORNIA ENERGY CODE (Title 24, Part 6, Chapter 1)
NONRESIDENTIAL MANDATORY MEASURES**

SERVICE WATER HEATING AND EQUIPMENT

§110.3 CERTIFICATION BY MANUFACTURERS

ANY SERVICE WATER-HEATING SYSTEM OR EQUIPMENT MAY BE INSTALLED ONLY IF THE MANUFACTURER HAS CERTIFIED THAT THE SYSTEM OR EQUIPMENT COMPLIES WITH ALL OF THE REQUIREMENTS OF CEC SECTION 110.3