

DSA CODE AMENDMENT DEVELOPMENT

Tracking	
Date Received:	-
DSA Tracking Number:	ITEM 1.01
Date Reviewed:	11/13/2018
Status:	Final Submittal

Applicable Code
Applicable Code Section(s): CBC Ch. 1, Sect. 1.9.1.1.3
Topic: Public housing

Current Code Language

1.9.1.1.1 All buildings, structures, sidewalks, curbs and related facilities constructed in the state by the use of state, county or municipal funds, or the funds of any political subdivision of the state.

1.9.1.1.2 All buildings, structures and facilities that are leased, rented, contracted, sublet or hired by any municipal, county or state division of government, or by a special district.

1.9.1.1.3 All publicly funded buildings used for congregate residences or for one- or two-family dwelling unit purposes shall conform to the provisions applicable to living accommodations.

1.9.1.1.4 All existing publicly funded buildings and facilities when alterations, structural repairs or additions are made to such buildings or facilities. For detailed requirements on existing buildings, see Chapter 11B, Division 2, Section 11B-202.

1.9.1.1.5 With respect to buildings, structures, sidewalks, curbs and related facilities not requiring a building permit, building standards published in the California Building Standards Code relating to access for persons with disabilities and other regulations adopted pursuant to Government Code Section 4450, and in effect at the time construction is commenced, shall be applicable.

Suggested Text of Proposed Amendment

1.9.1.1.1 All buildings, structures, sidewalks, curbs and related facilities constructed in the state by the use of state, county or municipal funds, or the funds of any political subdivision of the state. For public housing see Section 1.9.1.3.

1.9.1.1.2 All buildings, structures and facilities that are leased, rented, contracted, sublet or hired by any municipal, county or state division of government, or by a special district. For public housing see Section 1.9.1.3.

~~**1.9.1.1.3** All publicly funded buildings used for congregate residences or for one- or two-family dwelling unit purposes shall conform to the provisions applicable to living accommodations.~~

1.9.1.1.4 **1.9.1.1.3** All existing publicly funded buildings and facilities when alterations, structural repairs or additions are made to such buildings or facilities. For detailed requirements on existing buildings, see Chapter 11B, Division 2, Section 11B-202. . For public housing see Section 1.9.1.3.

~~**1.9.1.1.5**~~ **1.9.1.1.4** With respect to buildings, structures, sidewalks, curbs and related facilities not requiring a building permit, building standards published in the California Building Standards

DSA CODE AMENDMENT DEVELOPMENT

Code relating to access for persons with disabilities and other regulations adopted pursuant to Government Code Section 4450, and in effect at the time construction is commenced, shall be applicable.

Code Text if Adopted

1.9.1.1.1 *All buildings, structures, sidewalks, curbs and related facilities constructed in the state by the use of state, county or municipal funds, or the funds of any political subdivision of the state. For public housing see Section 1.9.1.3.*

1.9.1.1.2 *All buildings, structures and facilities that are leased, rented, contracted, sublet or hired by any municipal, county or state division of government, or by a special district. For public housing see Section 1.9.1.3.*

1.9.1.1.3 *All existing publicly funded buildings and facilities when alterations, structural repairs or additions are made to such buildings or facilities. For detailed requirements on existing buildings, see Chapter 11B, Division 2, Section 11B-202. For public housing see Section 1.9.1.3.*

1.9.1.1.4 *With respect to buildings, structures, sidewalks, curbs and related facilities not requiring a building permit, building standards published in the California Building Standards Code relating to access for persons with disabilities and other regulations adopted pursuant to Government Code Section 4450, and in effect at the time construction is commenced, shall be applicable.*

Rationale

- DSA is proposing to include the reference to Section 1.9.1.3 in Sections 1.9.1.1.1, 1.9.1.1.2 and 1.9.1.1.3. This amendment directs the code user to the definition in Chapter 2 for “*public housing.*” The definition, based on the American with Disabilities Act and the 2010 ADA Standards for Accessible Design, provides the clarity for the types of housing where Chapter 11B is applicable.
- DSA is proposing to repeal the reference to congregate residences and one- or two- family dwelling units in Section 1.9.1.1.3. Congregate residences and one- or two- family dwelling units are types of housing listed in the Chapter 2 definition of “*public housing.*” Congregate residences may also be regulated as a “place of public accommodation” when the use is a senior citizen center, homeless shelter or other social service center establishment. Therefore this language is redundant and inappropriate in this section.

CBSC-CAC Action: Approve as submitted.

DSA Response to CAC: Accepted.

Comments

DSA CODE AMENDMENT DEVELOPMENT

Tracking	
Date Received:	-
DSA Tracking Number:	ITEM 2.03
Date Reviewed:	11/13/2018
Status:	Final Submittal

Applicable Code
Applicable Code Section(s): Chapter 2, Section 202
Topic: Definition of Riser

Current Code Language

RISER. *The upright part between two adjacent stair treads.*

STEP. *A riser and tread.*

TREAD. *The horizontal part of a step.*

Suggested Text of Proposed Amendment

RISER. *The upright part between two adjacent stair treads, between either an upper or lower landing and an adjacent stair tread, or between two adjacent landings.*

STEP. *A riser and tread.*

TREAD. *The horizontal part of a step.*

Code Text if Adopted

RISER. *The upright part between two adjacent stair treads, between either an upper or lower landing and an adjacent stair tread, or between two adjacent landings.*

Rationale

DSA-AC is proposing to amend the definition of RISER for clarity and accuracy.

A stair is commonly understood to have a landing at the top and a landing at the bottom with one or more risers between. The California Building Code definition of RISER defeats the common understanding of a stair because the definition distinguishes risers “between two adjacent stair treads.” Using this definition, the upright part between a tread and a landing is not recognized as a riser.

If a flight does not have risers, as defined, then it is not a stair, as defined, and handrails are not required. This is a problem because the 2010 ADA Standards for Accessible Design requires handrails at stairs with as few as one riser (as commonly understood). The proposed change will correct this issue and in turn, will require handrails at all stairs with as few as one riser.

DSA-AC is also proposing to repeal the adoption of the terms STEP and RISER. Their definitions are unnecessary as the ordinary dictionary meaning will suffice.

CBSC-CAC Action: Approve as submitted.

DSA CODE AMENDMENT DEVELOPMENT

DSA Response to CAC: Accepted.

Comments

- Based on the US Access Board's *Guide to the Standards*, the *2010 ADA Standards for Accessible Design* requires handrails at stairs with as few as one riser (as commonly understood).
- Neither the *International Building Code* nor the ADA Standards define *RISER*, *STEP* or *TREAD*.
- Additional CBC Definitions:
 - **FLIGHT**. A continuous run of rectangular treads, winders or combination thereof from one landing to another.
 - **STAIR**. A change in elevation, consisting of one or more risers.
-

DSA CODE AMENDMENT DEVELOPMENT

Tracking	
Date Received:	-
DSA Tracking Number:	ITEM 11B.01
Date Reviewed:	11/13/2018
Status:	Final Submittal

Applicable Code
Applicable Code Section(s): CBC Ch. 11B, 11B-203.8
Topic: Scoping

Current Code Language

11B-203.8 Residential facilities. In *public housing* residential facilities, common use areas that do not serve residential dwelling units required to provide mobility features complying with *Sections 11B-809.2 through 11B-809.4 and adaptable features complying with Chapter 11A, Division IV* shall not be required to comply with these requirements or to be on an accessible route.

Suggested Text of Proposed Amendment

11B-203.8 Residential facilities. In ~~*public housing*~~ residential facilities, common use areas that do not serve residential dwelling units required to provide mobility features complying with *Sections 11B-809.2 through 11B-809.4 and adaptable features complying with Chapter 11A, Division IV* shall not be required to comply with these requirements or to be on an accessible route.

Code Text if Adopted

11B-203.8 Residential facilities. In residential facilities, common use areas that do not serve residential dwelling units required to provide mobility features complying with *Sections 11B-809.2 through 11B-809.4 and adaptable features complying with Chapter 11A, Division IV* shall not be required to comply with these requirements or to be on an accessible route.

Rationale

DSA is proposing to amend this section to delete the term “public housing.” This will provide for consistency in terminology with other sections of the code and remove redundant language.

CBSC-CAC Action: Approve as submitted.

DSA Response to CAC: Accepted.

Comments

DSA CODE AMENDMENT DEVELOPMENT

DSA CODE AMENDMENT DEVELOPMENT

Tracking	
Date Received:	-
DSA Tracking Number:	ITEM 11B.02
Date Reviewed:	11/13/2018
Status:	Final Submittal

Applicable Code
Applicable Code Section(s): 11B-206.2.19
Topic: Curb ramps

Current Code Language

N/A

Suggested Text of Proposed Amendment

11B-206.2.19 Pedestrian street crossings. *Where walks or sidewalks are provided, a curb ramp, blended transition, or a combination of curb ramps and blended transitions complying with Section 11B-406 shall connect the walks or sidewalks at each pedestrian street crossing. The curb ramp (excluding any flared sides) or blended transition shall be contained wholly within the width of the pedestrian street crossing served.*

EXCEPTION: *Compliance with Section 11B-206.2.19 shall not be required where pedestrian crossing is prohibited by the appropriate administrative authority.*

Code Text if Adopted

11B-206.2.19 Pedestrian street crossings. *Where walks or sidewalks are provided, a curb ramp, blended transition, or a combination of curb ramps and blended transitions complying with Section 11B-406 shall connect the walks or sidewalks at each pedestrian street crossing. The curb ramp (excluding any flared sides) or blended transition shall be contained wholly within the width of the pedestrian street crossing served.*

EXCEPTION: *Compliance with Section 11B-206.2.19 shall not be required where pedestrian crossing is prohibited by the appropriate administrative authority.*

Rationale

In the 2010 and prior editions of the CBC, scoping was provided for curb ramps at street intersections. DSA overlooked this section and did not bring it into the 2013 or 2016 codes. This code change proposal will restore the scoping requirement for curb ramps at street intersections.

CBSC-CAC Action: Short term further study.

DSA Response to CAC: Accepted. DSA has additionally studied this item and confirms the proposed revision is appropriate for inclusion in the California Building Code. Comments received at the Code Advisory Committee indicated the term “non-prohibited” was confusing. DSA has amended this section to provide an explicit exception for locations where pedestrian crossing is prohibited.

DSA CODE AMENDMENT DEVELOPMENT

Comments

- 2010 CBC:
1127B.5 Curb ramps.
1. General. Curb ramps shall be constructed at each corner of street intersections and where a pedestrian way crosses a curb. Built-up curb ramps shall be located so that they do not project into vehicular traffic lanes. The preferred and recommended location for curb ramps is in the center of the crosswalk of each street corner. Where it is necessary to locate a curb ramp in the center of the curb return and the street surfaces are marked to identify pedestrian crosswalks, the lower end of the curb ramp shall terminate within such crosswalk areas. See Figure 11B-20C, Case E and Figure 11B-22.
- US Access Board's *Accessibility Guidelines for Pedestrian Facilities in the Public Right-of-Way (2011)*:
R207.1 General. A curb ramp, blended transition, or a combination of curb ramps and blended transitions complying with R304 shall connect the pedestrian access routes at each pedestrian street crossing. The curb ramp (excluding any flared sides) or blended transition shall be contained wholly within the width of the pedestrian street crossing served.



DSA CODE AMENDMENT DEVELOPMENT

Tracking	
Date Received:	-
DSA Tracking Number:	ITEM 11B.03
Date Reviewed:	09/04/2018
Status:	Final Submittal

Applicable Code
Applicable Code Section(s): 11B-207.1
Topic: Accessible Means of Egress in Existing Buildings

Current Code Language

11B-207 Accessible means of egress

11B-207.1 General. Means of egress shall comply with *Chapter 10, Section 1009*.

Exceptions:

1. Where means of egress are permitted by local building or life safety codes to share a common path of egress travel, accessible means of egress shall be permitted to share a common path of egress travel.
2. Areas of refuge shall not be required in detention and correctional facilities.

Suggested Text of Proposed Amendment

11B-207 Accessible means of egress

11B-207.1 General. Means of egress shall comply with *Chapter 10, Section 1009*.

Exceptions:

1. Where means of egress are permitted by local building or life safety codes to share a common path of egress travel, accessible means of egress shall be permitted to share a common path of egress travel.
2. Areas of refuge shall not be required in detention and correctional facilities.
3. Accessible means of egress are not required to be provided in existing buildings.

Code Text if Adopted

11B-207 Accessible means of egress

11B-207.1 General. Means of egress shall comply with *Chapter 10, Section 1009*.

Exceptions:

DSA CODE AMENDMENT DEVELOPMENT

1. Where means of egress are permitted by local building or life safety codes to share a common path of egress travel, accessible means of egress shall be permitted to share a common path of egress travel.
2. Areas of refuge shall not be required in detention and correctional facilities.
3. *Accessible means of egress are not required to be provided in existing buildings.*

Rationale

DSA is proposing an amendment to include Exception 3 in Section 11B-207.1.

- This provision is currently in Chapter 10, Section 1009.1, Exception 1: “*Accessible means of egress are not required to be provided in existing buildings.*”
- This exception in Section 1009 of the 2015 International Building Code (IBC) has been relocated to Section 305.6 in the 2018 International Existing Building Code (IEBC). This section of the IEBC is not adopted by DSA for access compliance. The IBC is adopted as model code for fire/life safety therefore when the 2018 IBC is adopted this exception will not be in Chapter 10 of the California Building Code (CBC).
- By including Exception 3 in Section 11B-207.1 the provision will be carried forward and relocated in the 2019 CBC.

CBSC-CAC Action: Approve as submitted.

DSA Response to CAC: Accepted.

Comments

-



DSA CODE AMENDMENT DEVELOPMENT

Tracking	
Date Received:	-
DSA Tracking Number:	ITEM 11B.04
Date Reviewed:	11/13/2018
Status:	Final Submittal

Applicable Code
Applicable Code Section(s): 11B-224.2
Topic: Table for guest rooms with mobility features

Current Code Language

Table 11B-224.2 Guest Rooms with Mobility Features

Total Number of Guest Rooms Provided	Minimum Number of Required Rooms Without Roll-in Showers	Minimum Number of Required Rooms With Roll-in Showers	Total Number of Required Rooms
1 to 25	0	1	1
26 to 50	1	1	2
51 to 75	3	1	4
76 to 100	4	1	5
101 to 150	5	2	7
151 to 200	6	2	8
201 to 300	7	3	10
301 to 400	8	4	12
401 to 500	9	4	13
501 to 1000	2 percent of total	1 percent of total	3 percent of total
1001 and over	20, plus 1 for each 100, or fraction thereof, over 1000	10, plus 1 for each 100, or fraction thereof, over 1000	30, plus 2 for each 100, or fraction thereof, over 1000

Suggested Text of Proposed Amendment

Table 11B-224.2 Guest Rooms with Mobility Features

Total Number of Guest Rooms Provided	Minimum Number of Required Rooms Without Roll-in Showers ¹	Minimum Number of Required Rooms With Roll-in Showers ²	Total Number of Required Rooms
<u>1</u>	<u>1</u>	0	<u>1</u>
1 <u>2</u> to 25	0 <u>1</u>	1	1 <u>2</u>
26 to 50	1 <u>2</u>	1	2 <u>3</u>
51 to 75	3	1	4
76 to 100	4	1	5
101 to 150	5	2	7
151 to 200	6	2	8

DSA CODE AMENDMENT DEVELOPMENT

201 to 300	7	3	10
301 to 400	8	4	12
401 to 500	9	4	13
501 to 1000	2 percent of total	1 percent of total	3 percent of total
1001 and over	20, plus 1 for each 100, or fraction thereof, over 1000	10, plus 1 for each 100, or fraction thereof, over 1000	30, plus 2 for each 100, or fraction thereof, over 1000

1. Provide either a bathtub complying with Section 11B-607 or a transfer type shower complying with Section 11B-608.2.1.
2. Provide either a standard roll-in type shower complying with Section 11B-608.2.2 or an alternate type roll-in shower complying with Section 11B-608.2.3.

Code Text if Adopted

Table 11B-224.2 Guest Rooms with Mobility Features

Total Number of Guest Rooms Provided	Minimum Number of Required Rooms Without Roll-in Showers ¹	Minimum Number of Required Rooms With Roll-in Showers ²	Total Number of Required Rooms
1	1	0	1
2 to 25	1	1	2
26 to 50	2	1	3
51 to 75	3	1	4
76 to 100	4	1	5
101 to 150	5	2	7
151 to 200	6	2	8
201 to 300	7	3	10
301 to 400	8	4	12
401 to 500	9	4	13
501 to 1000	2 percent of total	1 percent of total	3 percent of total
1001 and over	20, plus 1 for each 100, or fraction thereof, over 1000	10, plus 1 for each 100, or fraction thereof, over 1000	30, plus 2 for each 100, or fraction thereof, over 1000

1. Provide either a bathtub complying with Section 11B-607 or a transfer type shower complying with Section 11B-608.2.1.
2. Provide either a standard roll-in type shower complying with Section 11B-608.2.2 or an alternate type roll-in shower complying with Section 11B-608.2.3.

Rationale

DSA is proposing this code change as a related amendment to transfer type shower compartments.

- Where only one room is provided in transient lodging facilities either an accessible bathtub or transfer type shower compartment may be provided.
- In transient lodging facilities with 2 to 25 or 26 to 50 guest rooms the number of guest rooms with mobility features will align with the requirements of the 2010 ADAS and allow for either an accessible bathtub or transfer type shower compartment.
- The number of guest rooms with roll-in type showers required by the CBC is maintained in transient lodging facilities with 2 to 25 or 26 to 50 guest rooms.
- Including the requirements in the 2010 ADAS and maintaining the requirements in the CBC makes necessary an increase in the overall number of guest rooms with mobility features in both categories.

DSA CODE AMENDMENT DEVELOPMENT

- This amendment also addresses questions from code users and will clarify where bathtubs and the various types of shower compartment are permitted.

CBSC-CAC Action: Further study.

DSA Response to CAC: Accepted. DSA has studied this item and has determined that no additional amendment to the table is necessary. DSA is aware that transient lodging facilities where only one guest room is provided are not the norm. The amendment to the table for requirements addressing facilities with one guestroom is in alignment with the table in the 2010 ADA Standards for Accessible Design.

Comments

DSA CODE AMENDMENT DEVELOPMENT



DSA CODE AMENDMENT DEVELOPMENT

Tracking	
Date Received:	-
DSA Tracking Number:	ITEM 11B.05
Date Reviewed:	11/13/2018
Status:	Final Submittal

Applicable Code
Applicable Code Section(s): CBC Ch. 11B, Sect. 11B-233.1
Topic: Scoping

Current Code Language

11B-233 Residential facilities

11B-233.1 General. *Public housing facilities with residential dwelling units available for public use shall comply with Section 11B-233. See Chapter 2, Section 202 of this code for the definition of Public Housing.*

Suggested Text of Proposed Amendment

11B-233 Residential Public housing facilities

11B-233.1 General. *Public housing facilities with residential dwelling units ~~available for public use~~ shall comply with Section 11B-233. See Chapter 2, Section 202 of this code for the definition of Public Housing.*

Code Text if Adopted

11B-233 *Public housing* facilities

11B-233.1 General. *Public housing facilities with residential dwelling units shall comply with Section 11B-233. See Chapter 2, Section 202 of this code for the definition of Public Housing.*

Rationale

DSA is proposing to amend this section to include the term “public housing” in the title of this section 11B-233.

Amending the title in the main section strengthens the link to the definition of “public housing” in Chapter 2.

The term “public housing” is proposed for deletion in the various scoping subsections to provide for consistency in terminology in other sections of the code and remove redundant language.

The phrase “*available for public use*” is proposed for repeal in the definition of public housing. The term lacks clarity for code users and is confused with the definition and requirements for places of public accommodation. The types of housing regulated as a place of public accommodation are facilities

DSA CODE AMENDMENT DEVELOPMENT

operated by private entities whose operation affect commerce and would not be considered public housing.

CBSC-CAC Action: Approve as submitted.

DSA Response to CAC: Accepted.

Comments

DSA CODE AMENDMENT DEVELOPMENT

Tracking	
Date Received:	-
DSA Tracking Number:	ITEM 11B.06
Date Reviewed:	11/13/2018
Status:	Final Submittal

Applicable Code
Applicable Code Section(s): CBC Ch. 11B, Sect. 11B-233.3.1
Topic: Residential Facilities

Current Code Language

11B-233.3.1 Minimum number: new construction. Newly constructed *public housing* facilities with residential dwelling units shall comply with *Section 11B-233.3.1*.

Exception:

11B-233.3.1.1 Residential dwelling units with mobility features. In *public housing* facilities with residential dwelling units, at least 5 percent, but no fewer than one unit, of the total number of residential dwelling units shall provide mobility features complying with *Sections 11B-809.2* through *11B-809.4* and shall be on an accessible route as required by *Section 11B-206*.

11B-233.3.1.2 Residential dwelling units with adaptable features. In *public housing* facilities with residential dwelling units, adaptable residential dwelling units complying with *Chapter 11A, Division IV – Dwelling Unit Features* shall be provided as required by *Sections 11B-233.3.1.2.1* through *11B-233.3.1.2.5*. Adaptable residential dwelling units shall be on an accessible route as required by *Section 11B-206*.

Exception:

11B-233.3.1.2.1 Elevator buildings.

11B-233.3.1.2.2 Non-elevator buildings.

11B-233.3.1.2.3 Ground floors above grade.

11B-233.3.1.2.4 Multi-story residential dwelling units in buildings with one or more elevators. In *elevator buildings*, *public housing* facilities with multi-story residential dwelling units shall comply with the following:

1. *The primary entry of the multi-story residential dwelling unit shall be on an accessible route on the floor served by the elevator.*
2. *At least one powder room or bathroom and kitchen shall be located on the primary entry level.*
3. *Rooms or spaces located on the primary entry level shall be served by an accessible route and comply with Chapter 11A, Division IV – Dwelling Units features.*

11B-233.3.1.2.5 Multi-story residential dwelling units in buildings with no elevator. In non-elevator buildings in public housing facilities, a minimum of 10 percent but not less than one of the ground floor multi-story residential dwelling units shall be calculated using the total number of multi-story residential dwelling units in buildings on a site and shall comply with the following:

1.
2.
3.

Suggested Text of Proposed Amendment

11B-233.3.1 Minimum number: new construction. Newly constructed ~~public housing~~ facilities with residential dwelling units shall comply with Section 11B-233.3.1.

Exception:

11B-233.3.1.1 Residential dwelling units with mobility features. In ~~public housing~~ facilities with residential dwelling units, at least 5 percent, but no fewer than one unit, of the total number of residential dwelling units shall provide mobility features complying with Sections 11B-809.2 through 11B-809.4 and shall be on an accessible route as required by Section 11B-206.

11B-233.3.1.2 Residential dwelling units with adaptable features. In ~~public housing~~ facilities with residential dwelling units, adaptable residential dwelling units complying with Chapter 11A, Division IV – Dwelling Unit Features shall be provided as required by Sections 11B-233.3.1.2.1 through ~~11B-233.3.1.2.5.~~ 11B-233.3.1.2.6. Adaptable residential dwelling units shall be on an accessible route as required by Section 11B-206.

Exception:

11B-233.3.1.2.1 Elevator buildings.

11B-233.3.1.2.2 Non-elevator buildings.

11B-233.3.1.2.3 Ground floors above grade.

11B-233.3.1.2.4 Multi-story residential dwelling units in buildings with one or more elevators. In elevator buildings, ~~public housing~~ facilities with multi-story residential dwelling units shall comply with the following:

1.
2.
3.

11B-233.3.1.2.5 Multi-story residential dwelling units in buildings with no elevator. In non-elevator buildings in ~~public housing~~ facilities, a minimum of 10 percent but not less than one of the ground floor multi-story residential dwelling units shall be calculated using the total number of multi-story residential dwelling units in buildings on a site and shall comply with the following:

1.
2.
3.

Code Text if Adopted

11B-233.3.1 Minimum number: new construction. Newly constructed facilities with residential dwelling units shall comply with *Section 11B-233.3.1*.

Exception:

11B-233.3.1.1 Residential dwelling units with mobility features. In facilities with residential dwelling units, at least 5 percent, but no fewer than one unit, of the total number of residential dwelling units shall provide mobility features complying with *Sections 11B-809.2 through 11B-809.4* and shall be on an accessible route as required by *Section 11B-206*.

11B-233.3.1.2 Residential dwelling units with adaptable features. In facilities with residential dwelling units, adaptable residential dwelling units complying with *Chapter 11A, Division IV – Dwelling Unit Features* shall be provided as required by *Sections 11B-233.3.1.2.1 through 11B-233.3.1.2.6*. Adaptable residential dwelling units shall be on an accessible route as required by *Section 11B-206*.

Exception:

11B-233.3.1.2.1 Elevator buildings.

11B-233.3.1.2.2 Non-elevator buildings.

11B-233.3.1.2.3 Ground floors above grade.

11B-233.3.1.2.4 Multi-story residential dwelling units in buildings with one or more elevators. In elevator buildings, facilities with multi-story residential dwelling units shall comply with the following:

1.
2.
3.

11B-233.3.1.2.5 Multi-story residential dwelling units in buildings with no elevator. In non-elevator buildings in ~~public housing~~ facilities, a minimum of 10 percent but not less than one of the ground floor multi-story residential dwelling units shall be calculated using the total number of multi-story residential dwelling units in buildings on a site and shall comply with the following:

1.
2.
3.

Rationale

DSA is proposing to amend this section to delete the term public housing. This will provide for consistency in terminology in other sections of the code and remove redundant language.

An editorial change is proposed for Section 11B-233.3.1.2 to amend the reference to include Section 11B-233.3.1.2.6 for the site impracticality test.

CBSC-CAC Action: Approve as submitted.
DSA Response to CAC: Accepted.

Comments



DSA CODE AMENDMENT DEVELOPMENT

Tracking	
Date Received:	-
DSA Tracking Number:	ITEM 11B.08
Date Reviewed:	11/13/2018
Status:	Final Submittal

Applicable Code
Applicable Code Section(s): CBC Ch. 11B, Sect. 11B-233.3.3
Topic: Additions

Current Code Language

11B-233.3.3 Additions. Where an addition to an existing *public housing facility* results in an increase in the number of residential dwelling units, the requirements of *Section 11B-233.3.1* shall apply only to the residential dwelling units that are added until the total number of residential dwelling units complies with the minimum number required by *Section 11B-233.3.1*. Residential dwelling units required to comply with *Sections 11B-233.3.1.1 and 11B-233.3.1.2* shall be on an accessible route as required by *Section 11B-206*.

Suggested Text of Proposed Amendment

11B-233.3.3 Additions. Where an addition to an existing ~~*public housing facility*~~ building results in an increase in the number of residential dwelling units, the requirements of *Section 11B-233.3.1* shall apply only to the residential dwelling units that are added until the total number of residential dwelling units complies with the minimum number required by *Section 11B-233.3.1*. Residential dwelling units required to comply with *Sections 11B-233.3.1.1 and 11B-233.3.1.2* shall be on an accessible route as required by *Section 11B-206*.

Code Text if Adopted

11B-233.3.3 Additions. Where an addition to an existing building results in an increase in the number of residential dwelling units, the requirements of *Section 11B-233.3.1* shall apply only to the residential dwelling units that are added until the total number of residential dwelling units complies with the minimum number required by *Section 11B-233.3.1*. Residential dwelling units required to comply with *Sections 11B-233.3.1.1 and 11B-233.3.1.2* shall be on an accessible route as required by *Section 11B-206*.

Rationale

DSA is proposing to amend this section to delete “*public housing facility*.” The current provision limits the requirements to existing public housing facilities where additions are planned. An addition to an existing building may be undertaken as part of a program on behalf of a public entity that would then require compliance with Chapter 11B if the project meets the definition of public housing in Chapter 2. As written, existing facilities that are not public housing would be exempt from compliance with this section. The proposed amendment is also consistent with language in the 2010 ADA Standards for Accessible Design.

CBSC-CAC Action: Approve as submitted.
DSA Response to CAC: Accepted.

Comments

DSA CODE AMENDMENT DEVELOPMENT

Tracking	
Date Received:	-
DSA Tracking Number:	ITEM 11B.09
Date Reviewed:	11/13/2018
Status:	Final Submittal

Applicable Code
Applicable Code Section(s): CBC Ch. 11B, Sect. 11B-233.3.4, 11B-233.3.4.1, 11B-233.3.4.2
Topic: Alterations

Current Code Language

11B-233.3.4 Alterations. Alterations to a public housing facility shall comply with Section 11B-233.3.4.

Exception: Where compliance with Section 11B-809.2, 11B-809.3, or 11B-809.4 for units with mobility features or Chapter 11A, Division IV for units with adaptable features is technically infeasible, or where it is technically infeasible to provide an accessible route to a residential dwelling unit, the entity shall be permitted to alter or construct a comparable residential dwelling unit to comply with Sections 11B-809.2 through 11B-809.4 or Chapter 11A, Division IV provided that the minimum number of residential dwelling units required by Sections 11B-233.3.1.1, 11B-233.3.1.2 and 11B-233.3.1.3, as applicable, is satisfied.

11B-233.3.4.1 Alterations to vacated buildings. Where a building is vacated for the purposes of alteration for use as public housing, and the altered building contains more than 15 residential dwelling units, at least 5 percent of the residential dwelling units shall comply with Sections 11B-809.2 through 11B-809.4 and shall be on an accessible route as required by Section 11B-206. Residential dwelling units with adaptable features shall be provided in compliance with Section 11B-233.3.1.2. In addition, at least 2 percent of the residential dwelling units shall comply with Section 11B-809.5.

Exception: Where any portion of a building's exterior is preserved, but the interior of the building is removed, including all structural portions of floors and ceilings and a new building intended for use as public housing is constructed behind the existing exterior, the building is considered a new building for determining the application of this chapter.

11B-233.3.4.2 Alterations to individual residential dwelling units. In public housing facilities with individual residential dwelling units, where a bathroom or a kitchen is substantially altered, and at least one other room is altered, the requirements of Section 11B-233.3.1 shall apply to the altered residential dwelling units until the total number of residential dwelling units complies with the minimum number required by Sections 11B-233.3.1.1, 11B-233.3.1.2, and 11B-233.3.1.3. Residential dwelling units required to comply with Sections 11B-233.3.1.1 and 11B-233.3.1.2 shall be on an accessible route as required by Section 11B-206.

Exception: Where public housing facilities contain 15 or fewer residential dwelling units, the requirements of Sections 11B-233.3.1.1, 11B-233.3.1.2, and 11B-233.3.1.3 shall apply to

the total number of residential dwelling units that are altered under a single contract, or are developed as a whole, whether or not located on a common site.

Suggested Text of Proposed Amendment

11B-233.3.4 Alterations. Alterations ~~to a public housing facility~~ shall comply with Section 11B-233.3.4.

Exception: Where compliance with Section 11B-809.2, 11B-809.3, or 11B-809.4 ~~for units with mobility features or Chapter 11A, Division IV for units with adaptable features~~ is technically infeasible, or where it is technically infeasible to provide an accessible route to a residential dwelling unit, the entity shall be permitted to alter or construct a comparable residential dwelling unit to comply with Sections 11B-809.2 through 11B-809.4 ~~or Chapter 11A, Division IV~~ provided that the minimum number of residential dwelling units required by Sections 11B-233.3.1.1, ~~11B-233.3.1.2 and 11B-233.3.1.3~~, as applicable, is satisfied.

11B-233.3.4.1 Alterations to vacated buildings. Where a building is vacated for the purposes of alteration ~~for use as public housing~~, and the altered building contains more than 15 residential dwelling units, at least 5 percent of the residential dwelling units shall comply with Sections 11B-809.2 through 11B-809.4 and shall be on an accessible route as required by Section 11B-206. ~~Residential dwelling units with adaptable features shall be provided in compliance with Section 11B-233.3.1.2.~~ In addition, at least 2 percent of the residential dwelling units shall comply with Section 11B-809.5.

Exception: ~~Where any portion of a building's exterior is preserved, but the interior of the building is removed, including all structural portions of floors and ceilings and a new building intended for use as public housing is constructed behind the existing exterior, the building is considered a new building for determining the application of this chapter.~~

11B-233.3.4.2 Alterations to individual residential dwelling units. In ~~public housing facilities with~~ individual residential dwelling units, where a bathroom or a kitchen is substantially altered, and at least one other room is altered, the requirements of Section 11B-233.3.1 shall apply to the altered residential dwelling units until the total number of residential dwelling units complies with the minimum number required by Sections 11B-233.3.1.1, ~~11B-233.3.1.2~~, and 11B-233.3.1.3. Residential dwelling units required to comply with ~~Sections~~ Section 11B-233.3.1.1 ~~and 11B-233.3.1.2~~ shall be on an accessible route as required by Section 11B-206.

Exception: Where ~~public housing~~ facilities contain 15 or fewer residential dwelling units, the requirements of Sections 11B-233.3.1.1, ~~11B-233.3.1.2~~, and 11B-233.3.1.3 shall apply to the total number of residential dwelling units that are altered under a single contract, or are developed as a whole, whether or not located on a common site.

11B-233.3.4.3 Alterations to residential dwelling units with adaptable features. The building standards for residential dwelling units with adaptable features do not apply to the alteration, repair, rehabilitation or maintenance of residential dwelling units constructed for first occupancy on or prior to March 13, 1991. Multifamily dwelling units with adaptable features constructed for first occupancy after March 13, 1991 shall be maintained in compliance with the accessibility standards in effect at the time of construction.

Exception: Where any portion of a building's exterior is preserved, but the interior of the building is removed, including all structural portions of floors and ceilings and a new building is constructed behind the existing exterior, the building is considered a new building for determining the application of this chapter.

Code Text if Adopted

11B-233.3.4 Alterations. Alterations shall comply with *Section 11B-233.3.4*.

Exception: Where compliance with *Section 11B-809.2*, *11B-809.3*, or *11B-809.4* is technically infeasible, or where it is technically infeasible to provide an accessible route to a residential dwelling unit, the entity shall be permitted to alter or construct a comparable residential dwelling unit to comply with *Sections 11B-809.2* through *11B-809.4* provided that the minimum number of residential dwelling units required by *Sections 11B-233.3.1.1* and *11B-233.3.1.3*, as applicable, is satisfied.

11B-233.3.4.1 Alterations to vacated buildings. Where a building is vacated for the purposes of alteration, and the altered building contains more than 15 residential dwelling units, at least 5 percent of the residential dwelling units shall comply with *Sections 11B-809.2* through *11B-809.4* and shall be on an accessible route as required by *Section 11B-206*. In addition, at least 2 percent of the residential dwelling units shall comply with *Section 11B-809.5*.

11B-233.3.4.2 Alterations to individual residential dwelling units. In individual residential dwelling units, where a bathroom or a kitchen is substantially altered, and at least one other room is altered, the requirements of *Section 11B-233.3.1* shall apply to the altered residential dwelling units until the total number of residential dwelling units complies with the minimum number required by *Sections 11B-233.3.1.1* and *11B-233.3.1.3*. Residential dwelling units required to comply with *Section 11B-233.3.1.1* shall be on an accessible route as required by *Section 11B-206*.

Exception: Where facilities contain 15 or fewer residential dwelling units, the requirements of *Sections 11B-233.3.1.1* and *11B-233.3.1.3* shall apply to the total number of residential dwelling units that are altered under a single contract, or are developed as a whole, whether or not located on a common site.

11B-233.3.4.3 Alterations to residential dwelling units with adaptable features. *The building standards for residential dwelling units with adaptable features do not apply to the alteration, repair, rehabilitation or maintenance of residential dwelling units constructed for first occupancy on or prior to March 13, 1991. Multifamily dwelling units with adaptable features constructed for first occupancy after March 13, 1991 shall be maintained in compliance with the accessibility standards in effect at the time of construction.*

Exception: *Where any portion of a building's exterior is preserved, but the interior of the building is removed, including all structural portions of floors and ceilings and a new building is constructed behind the existing exterior, the building is considered a new building for determining the application of this chapter.*

Rationale

DSA is proposing the following amendments:

- DSA is proposing to delete the references to public housing facilities in *Section 11B-233.3.4*. The language as currently written would exempt alterations to existing buildings that are not public housing facilities. This allows for an alteration to existing buildings without triggering compliance with Chapter 11B. An existing building may not be a public housing facility; however the altered facility may meet the definition of public housing (by, for, or on behalf of a public

entity). In addition this change aligns the language with the 2010 ADA Standards for Accessible Design that regulates alterations to existing buildings.

- DSA is proposing to amend Sections 11B-233.3.4, 11B-233.3.4.1, 11B-233.3.4.2 and related exceptions to delete the references to Chapter 11A, Division IV.
- A new Section 11B-233.3.4.3 is proposed to address alterations to residential dwelling units with adaptable features.
- In CBC editions prior to 2013 Section 1102A, that includes March 13, 1991 as the date that requires compliance with Chapter 11A, was adopted by DSA-AC for covered multi-family dwelling units. Currently DSA adopts Division IV of Chapter 11A for the dwelling unit features. In Division IV there is a note that requires compliance with Section 1102A which includes the trigger date of March 13, 1991 for alterations to covered multifamily dwelling units.
- DSA is proposing to make explicit the applicability of March 13, 1991 in Chapter 11B for alterations to multifamily dwelling units rather than by following the code path through Division IV in Chapter 11A. This proposed amendment aligns Chapter 11B with the Fair Housing Act Accessibility Guidelines.
- The exception in Section 11B-233.3.4.1, applicable to a building when reconstructed behind the shell of an existing building, is proposed for relocation under the new Section 11B-233.3.4.3. The phrase “*intended for use as public housing*” is proposed for repeal in the exception. This amendment aligns Chapter 11B with the requirements in Chapter 11A and the Fair Housing Act Accessibility Guidelines.

CBSC-CAC Action: Further study.

DSA Response to CAC: Accepted. DSA has gathered additional data from various building departments and housing successor agencies in response to a public commenter who remarked that the number of accessible units is diminished by this code change proposal. DSA has followed up with the commenter and has conducted additional research but has not been able to substantiate the commenter’s assertion.

A representative from the California Department of Housing and Community Development (HCD) expressed that agency’s support for this code change proposal at the code advisory committee hearing. HCD is the agency responsible for promulgating CBC, Chapter 11A Housing Accessibility which is based on the Fair Housing Act Guidelines.

The date of March 13, 1991, for covered multifamily housing constructed for first occupancy, is consistent with the requirements in the Fair Housing Act Guidelines. Covered multifamily dwelling must be maintained in compliance with the guidelines and are exempt from requirements for alterations.

Note: The BSC Commission Action Matrix previously indicated Code Advisory Committee Action on Item 11B.09 (all four sub-items) as ST/FS (Short Term Further Study). This notation has been corrected to indicate FS (Further Study).

Comments



DSA CODE AMENDMENT DEVELOPMENT

Tracking	
Date Received:	-
DSA Tracking Number:	ITEM 11B.10
Date Reviewed:	11/13/2018
Status:	Final Submittal

Applicable Code
Applicable Code Section(s): CBC Ch. 11B, Sect. 11B-233.3.5
Topic: Dispersion

Current Code Language

11B-233.3.5 Dispersion. *In public housing facilities, residential dwelling units required to provide mobility features complying with Sections 11B-809.2 through 11B-809.4 and residential dwelling units required to provide communication features complying with Section 11B-809.5, and adaptable features complying with Chapter 11A, Division IV shall be dispersed among the various types of residential dwelling units in the facility and shall provide choices of residential dwelling units comparable to, and integrated with, those available to other residents.*

Exception: *In public housing facilities where multi-story residential dwelling units are one of the types of residential dwelling units provided, one-story residential dwelling units shall be permitted as a substitute for multi-story residential dwelling units where equivalent spaces and amenities are provided in the one-story residential dwelling unit.*

Suggested Text of Proposed Amendment

11B-233.3.5 Dispersion. *In public housing facilities, residential Residential dwelling units required to provide mobility features complying with Sections 11B-809.2 through 11B-809.4 and residential dwelling units required to provide communication features complying with Section 11B-809.5, ~~and adaptable features complying with Chapter 11A, Division IV~~ shall be dispersed among the various types of residential dwelling units in the facility and shall provide choices of residential dwelling units comparable to, and integrated with, those available to other residents.*

Exception: *~~In public housing facilities where~~ Where multi-story residential dwelling units are one of the types of residential dwelling units provided, one-story residential dwelling units shall be permitted as a substitute for multi-story residential dwelling units where equivalent spaces and amenities are provided in the one-story residential dwelling unit.*

Code Text if Adopted

11B-233.3.5 Dispersion. Residential dwelling units required to provide mobility features complying with Sections 11B-809.2 through 11B-809.4 and residential dwelling units required to provide communication features complying with Section 11B-809.5 shall be dispersed among the various types of residential dwelling units in the facility and shall provide choices of residential dwelling units comparable to, and integrated with, those available to other residents.

Exception: Where multi-story residential dwelling units are one of the types of residential dwelling units provided, one-story residential dwelling units shall be permitted as a substitute for multi-story residential dwelling units where equivalent spaces and amenities are provided in the one-story residential dwelling unit.

Rationale

DSA is proposing to amend this section to:

- Delete the reference to Chapter 11A. This section is specific to residential dwelling units with mobility features where an accessible route is required throughout the unit. In a multi-story dwelling unit with mobility features a residential elevator or platform lift is required to provide an accessible route to all finished floors within the dwelling unit. When the exception is used it allows for a single story residential dwelling unit to be provided in lieu of a multi-story residential dwelling unit. The single story unit must provide the same amenities as a multi-story dwelling unit. Chapter 11A requires an accessible route only to the primary entry of multi-story dwelling units in buildings with elevators or ten percent of multi-story dwelling units in buildings without elevators.
- Repeal the redundant language of *“In public housing facilities.”* The main Section 11B-233.3 in the title and the opening provisions references public housing facilities. The continued use of *“public housing facilities”* in some cases also causes an unintended consequence and may relieve the requirement for compliance with Chapter 11B that is necessary.

This proposed amendment aligns Chapter 11B with the 2010 ADAS and the Fair Housing Act Accessibility Guidelines and will provide clarity and consistency for code users.

CBSC-CAC Action: Approve as submitted.

DSA Response to CAC: Accepted.

Comments



DSA CODE AMENDMENT DEVELOPMENT

Tracking	
Date Received:	-
DSA Tracking Number:	ITEM 11B.11
Date Reviewed:	11/13/2018
Status:	Final Submittal

Applicable Code
Applicable Code Section(s): 11B-248
Topic: Scoping for common use areas and employee work areas.

Current Code Language

11B-201.1 Scope. All areas of newly designed and newly constructed buildings and facilities and altered portions of existing buildings and facilities shall comply with these requirements.

Suggested Text of Proposed Amendment

11B-248 Common use areas and employee work areas.

11B-248.1 Common use areas. Common use areas shall comply with this chapter.

11B-248.2 Employee work areas. Employee work areas shall comply with this chapter.

Code Text if Adopted

11B-248 Common use areas and employee work areas.

11B-248.1 Common use areas. Common use areas shall comply with this chapter.

11B-248.2 Employee work areas. Employee work areas shall comply with this chapter.

Rationale

2010 and prior editions of the CBC had scoping requirements for common use areas (various sections) and employee work areas (1123B and various sections). During the 2012 rulemaking cycle, DSA decided not to include scoping for common use and employee work areas because Section 11B-201.1 indicated “All areas...shall comply with these requirements.” which DSA understands to include common use areas and employee work areas. However, DSA has heard enough confusion on this issue to propose adding explicit scoping to clarify that common use areas and employee work areas are required to comply with the accessibility provisions of CBC Chapter 11B.

CBSC-CAC Action: Short term further study.

DSA Response to CAC: Accepted. DSA has additionally studied this item and confirms the proposed revision is appropriate for inclusion in the California Building Code. The CAC also suggested separating the scoping sections for common use areas and employee work areas. In response, DSA has reformatted the proposal to provide separate scoping sections.

Comments

DSA CODE AMENDMENT DEVELOPMENT



DSA CODE AMENDMENT DEVELOPMENT

Tracking	
Date Received:	-
DSA Tracking Number:	ITEM 11B.12, RELATED ITEMS 11B.12.01, 11B.12.02, and 11B-12.03
Date Reviewed:	11/13/2018
Status:	Final Submittal

Applicable Code
Applicable Code Section(s): 202, 11B-249, 11B-813
Topic: Adult changing facilities

Current Code Language

N/A

Suggested Text of Proposed Amendment

Chapter 2, Section 202 – Definitions

Commercial place of public amusement. *An auditorium, convention center, cultural complex, exhibition hall, permanent amusement park, sports arena, theater or movie house for which the maximum occupancy is 2,500 or more for the facility. Cultural complexes include but are not limited to art galleries, symphony, concert halls, and museums. A commercial place of public amusement does not include any public or private higher education facility or district agricultural associations.*

District Agricultural Associations. *Those associations regulated by the California Food and Agricultural Code, Division 3, Part 3.*

Adult changing facility. *A facility that is for use by persons with disabilities who need assistance with personal hygiene.*

Chapter 11B, Section 11B-249

11B-249. Adult changing facilities.

11B-249.1 General. *Adult changing facilities shall comply with Section 11B-249.*

11B-249.1.1 *Where adult changing facilities are provided, each adult changing facility shall comply with Section 11B-813.*

11B-249.1.2 *Newly constructed commercial places of public amusement shall provide no fewer than one adult changing facility in compliance with Section 11B-813.*

Chapter 11B, Section 11B-813

11B-813. Adult changing facilities. *Adult changing facilities shall comply with Section 11B-813.*

DSA CODE AMENDMENT DEVELOPMENT

11B-813.1 Location. *Adult changing facilities shall be provided within a unisex (single-user or family) toilet room or other similar private room.*

11B-813.2 Features. *Adult changing facilities shall provide features in compliance with Section 11B-813.2.*

11B-813.2.1 Adult changing table. *Adult changing tables shall be fixed to the floor or a wall and shall comply with Section 11B-813.2.1.*

11B-813.2.1.1 Size. *Adult changing tables shall have a changing surface of 70 inches minimum length and 30 inches minimum width.*

11B-813.2.1.2 Clearance. *A 36 inches minimum width side clearance shall be provided along the entire length of one side of adult changing tables. At both ends of adult changing tables, clearance shall be provided measuring 36 inches minimum wide and a minimum length as long as the table width plus the width of the side clearance. End and side clearances shall be measured from the outermost extent of the table. Floor or ground surfaces of clearances shall comply with Section 11B-302. Changes in level are not permitted.*

11B-813.2.1.3 Height and operation. *Adult changing table height shall be adjustable from 17 inches above the floor or ground to 38 inches above the floor or ground, as measured to the top of the changing surface. Height adjustability shall be powered. Operable parts shall comply with Section 11B-309.*

11B-813.2.1.4 Capacity. *Adult changing tables shall provide a minimum weight capacity of 300 pounds.*

11B-813.2.1.5 Obstructions. *When deployed, changing tables shall not obstruct the required width of an accessible route except as allowed by Section 11B-307.2.*

11B-813.2.2 Water closet. *No fewer than one water closet in compliance with Section 11B-604.*

11B-813.2.3 Lavatory. *One lavatory in compliance with Section 11B-606.*

11B-813.2.4 Waste receptacle. *No fewer than one waste receptacle in compliance with Section 11B-603.5.*

11B -813.2.5 Coat hook. *No fewer than one coat hook shall be provided in close proximity to the changing table and within one of the reach ranges specified in Section 11B-308.*

11B-813.2.6 Shelf. *No fewer than one shelf shall be provided in close proximity to the changing table at 40 inches minimum and 48 inches maximum above the finish floor.*

11B-813.2.7 Accessories. *Where provided, no fewer than one of each accessory shall comply with Section 11B-603.5.*

11B-813.2.8 Turning space. *Turning space complying with Section 11B-304 shall be provided within adult changing facilities.*

11B-813.2.9 Overlap. *Required clear floor spaces, clearance at fixtures, and turning space shall be permitted to overlap.*

11B-813.2.10 Door swing. *A door, in any position, shall be permitted to encroach into the turning space by 12 inches maximum. Where a clear floor space complying with Section 11B-305.3 is provided within the room beyond the arc of the door swing, doors shall be permitted to*

DSA CODE AMENDMENT DEVELOPMENT

swing into the clear floor space, clearance required for any fixture, and clearance required for adult changing tables.

11B-813.2.11 Privacy latch. Each door to adult changing facilities shall have a privacy latch.

11B-813.2.12 Signs. A room identification sign complying with Section 11B-216 shall be provided at entrances to adult changing facilities. The text of the room identification sign shall be "ADULT CHANGING FACILITY".

An informational sign complying with Section 11B-216 shall be provided within adult changing facilities and in close proximity to the changing table. The informational sign shall indicate the maximum weight capacity of the adult changing table, as determined by the table manufacturer.

Where the commercial place of public amusement has a central directory, the central directory shall indicate the location of adult changing facilities. Where other directories indicate the location of toilet facilities, the other directories shall also indicate the location of adult changing facilities.

Related:

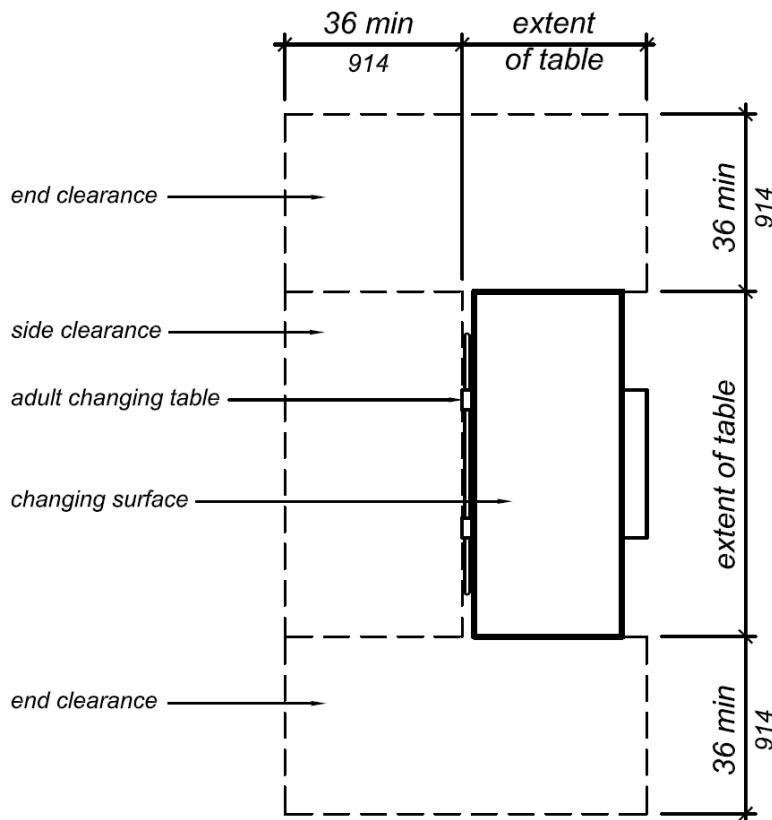

FIGURE 11B-813.2.1.2
CLEARANCE AROUND ADULT CHANGING TABLE

DSA CODE AMENDMENT DEVELOPMENT**Code Text if Adopted**

Commercial place of public amusement. *An auditorium, convention center, cultural complex, exhibition hall, permanent amusement park, sports arena, theater or movie house for which the maximum occupancy is 2,500 or more for the facility. Cultural complexes include but are not limited to art galleries, symphony, concert halls, and museums. A commercial place of public amusement does not include any public or private higher education facility or district agricultural associations.*

District Agricultural Associations. *Those associations regulated by the California Food and Agricultural Code, Division 3, Part 3.*

Adult changing facility. *A facility that is for use by persons with disabilities who need assistance with personal hygiene.*

Chapter 11B, Section 11B-249**11B-249. Adult changing facilities.**

11B-249.1 General. *Adult changing facilities shall comply with Section 11B-249.*

11B-249.1.1 *Where adult changing facilities are provided, each adult changing facility shall comply with Section 11B-813.*

11B-249.1.2 *Newly constructed commercial places of public amusement shall provide no fewer than one adult changing facility in compliance with Section 11B-813.*

Chapter 11B, Section 11B-813

11B-813. Adult changing facilities. *Adult changing facilities shall comply with Section 11B-813.*

11B-813.1 Location. *Adult changing facilities shall be provided within a unisex (single-user or family) toilet room or other similar private room.*

11B-813.2 Features. *Adult changing facilities shall provide features in compliance with Section 11B-813.2.*

11B-813.2.1 Adult changing table. *Adult changing tables shall be fixed to the floor or a wall and shall comply with Section 11B-813.2.1.*

11B-813.2.1.1 Size. *Adult changing tables shall have a changing surface of 70 inches minimum length and 30 inches minimum width.*

11B-813.2.1.2 Clearance. *A 36 inches minimum width side clearance shall be provided along the entire length of one side of adult changing tables. At both ends of adult changing tables, clearance shall be provided measuring 36 inches minimum wide and a minimum length as long as the table width plus the width of the side clearance. End and side clearances shall be measured from the outermost extent of the table. Floor or ground surfaces of clearances shall comply with Section 11B-302. Changes in level are not permitted.*

DSA CODE AMENDMENT DEVELOPMENT

11B-813.2.1.3 Height and operation. Adult changing table height shall be adjustable from 17 inches above the floor or ground to 38 inches above the floor or ground, as measured to the top of the changing surface. Height adjustability shall be powered. Operable parts shall comply with Section 11B-309.

11B-813.2.1.4 Capacity. Adult changing tables shall provide a minimum weight capacity of 300 pounds.

11B-813.2.1.5 Obstructions. When deployed, changing tables shall not obstruct the required width of an accessible route except as allowed by Section 11B-307.2.

11B-813.2.2 Water closet. No fewer than one water closet in compliance with Section 11B-604.

11B-813.2.3 Lavatory. One lavatory in compliance with Section 11B-606.

11B-813.2.4 Waste receptacle. No fewer than one waste receptacle in compliance with Section 11B-603.5.

11B-813.2.5 Coat hook. No fewer than one coat hook shall be provided in close proximity to the changing table and within one of the reach ranges specified in Section 11B-308.

11B-813.2.6 Shelf. No fewer than one shelf shall be provided in close proximity to the changing table at 40 inches minimum and 48 inches maximum above the finish floor.

11B-813.2.7 Accessories. Where provided, no fewer than one of each accessory shall comply with Section 11B-603.5.

11B-813.2.8 Turning space. Turning space complying with Section 11B-304 shall be provided within adult changing facilities.

11B-813.2.9 Overlap. Required clear floor spaces, clearance at fixtures, and turning space shall be permitted to overlap.

11B-813.2.10 Door swing. A door, in any position, shall be permitted to encroach into the turning space by 12 inches maximum. Where a clear floor space complying with Section 11B-305.3 is provided within the room beyond the arc of the door swing, doors shall be permitted to swing into the clear floor space, clearance required for any fixture, and clearance required for adult changing tables.

11B-813.2.11 Privacy latch. Each door to adult changing facilities shall have a privacy latch.

11B-813.2.12 Signs. A room identification sign complying with Section 11B-216 shall be provided at entrances to adult changing facilities. The text of the room identification sign shall be "ADULT CHANGING FACILITY".

An informational sign complying with Section 11B-216 shall be provided within adult changing facilities and in close proximity to the changing table. The informational sign shall indicate the maximum weight capacity of the adult changing table, as determined by the table manufacturer.

Where the commercial place of public amusement has a central directory, the central directory shall indicate the location of adult changing facilities. Where other directories indicate the location of toilet facilities, the other directories shall also indicate the location of adult changing facilities.

DSA CODE AMENDMENT DEVELOPMENT

Related:

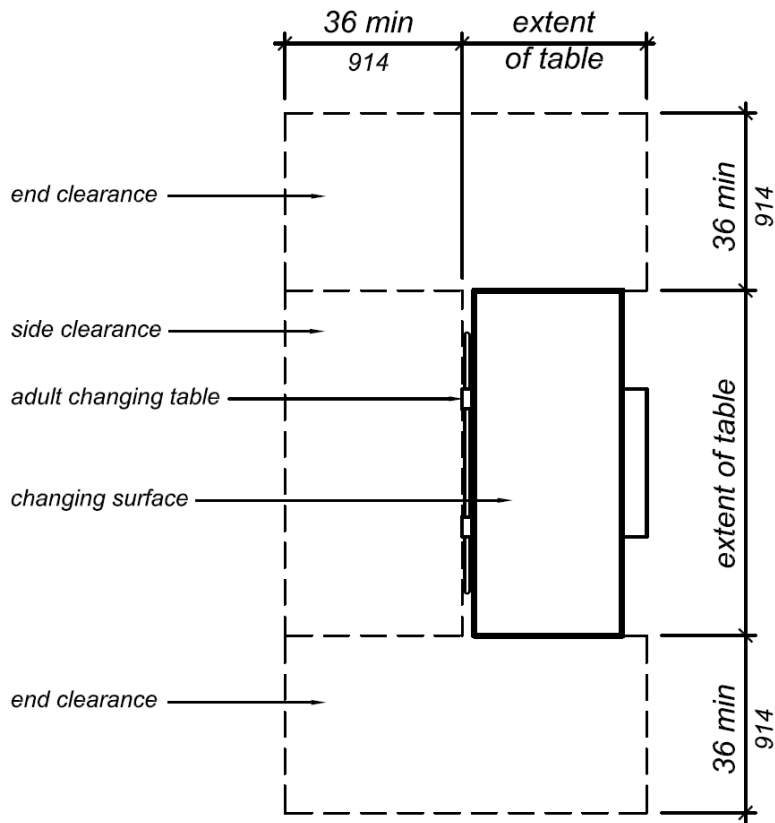

**FIGURE 11B-813.2.1.2
CLEARANCE AROUND ADULT CHANGING TABLE**

Rationale

DSA-AC is proposing new definitions, scoping and technical accessibility code requirements for adult changing facilities in response to Assembly Bill 662 (2015-2016) / California Health & Safety Code §19952.5. Consistent with statute, this proposal requires an adult changing facility at newly constructed commercial places of public amusement, as defined. This proposal also provides specific requirements for other adult changing facilities that are optionally provided. DSA convened an Adult Changing Facility Task Force which met five times in 2017 to solicit input on the scoping and technical requirements for these facilities.

CBSC-CAC Action: Further study.

DSA Response to CAC: Accepted. DSA has additionally studied this item and confirms the proposed revision is appropriate for inclusion in the California Building Code; this includes use of the term “maximum occupancy.” The CAC made several additional suggestions to improve clarity of the language and DSA has amended the express terms to address these issues.

DSA CODE AMENDMENT DEVELOPMENT

Note: The BSC Commission Action Matrix previously indicated Code Advisory Committee Action on Item 11B.12 (all four sub-items) as ST/FS (Short Term Further Study). This notation has been corrected to indicate FS (Further Study).

Comments

- California Health & Safety Code [19952.5](#).
 - (a) A person, private firm, organization, or corporation that owns or manages a commercial place of public amusement shall install and maintain at least one adult changing station for persons with a physical disability that is accessible to both men and women when the facility is open to the public, if either of the following occur:
 - (1) The commercial place of public amusement is newly constructed on or after January 1, 2020.
 - (2) (A) When an existing commercial place of public amusement is renovated on or after January 1, 2025, and requires a permit or the estimated cost of the renovation is ten thousand dollars (\$10,000) or more.
 - (B) A commercial place of public amusement with an enclosed restroom facility or other similar private facility with an adult changing table in use before January 1, 2025, shall be deemed to comply with this paragraph.
 - (b) A facility shall ensure that the entrance to each adult changing station has conspicuous signage indicating the location of the station, and, if the facility has a central directory, shall ensure that the central directory indicates the location of the adult changing station.
 - (c) For purposes of this section, all of the following definitions shall apply:
 - (1) “Commercial place of public amusement” means an auditorium, convention center, cultural complex, exhibition hall, permanent amusement park, sports arena, or theater or movie house for which the maximum occupancy is determined to be 2,500 or more people. “Commercial place of public amusement” does not include any public or private higher education facility or district agricultural association.
 - (2) “Adult changing station” means an adult changing table placed within an enclosed restroom facility or other similar private facility that is for use by persons with physical disabilities who need help with diapering.
 - (3) “Physical disability” means a mental or physical disability, as described in Section 12926 of the Government Code.
- (Added by Stats. 2015, Ch. 742, Sec. 1. (AB 662) Effective January 1, 2016.)*

DSA CODE AMENDMENT DEVELOPMENT

DSA CODE AMENDMENT DEVELOPMENT

Tracking	
Date Received:	-
DSA Tracking Number:	ITEM 11B.13
Date Reviewed:	11/13/2018
Status:	Final Submittal

Applicable Code
Applicable Code Section(s): 11B-404.2.11
Topic: Door vision lights – exception for detention and correctional facilities

Current Code Language

11B-404.2.11 Vision lights. Doors, gates, and side lights adjacent to doors or gates, containing one or more glazing panels that permit viewing through the panels shall have the bottom of at least one glazed panel located 43 inches (1092 mm) maximum above the finish floor.

Exception: *Glazing panels* with the lowest part more than 66 inches (1676 mm) from the finish floor or ground shall not be required to comply with *Section 11B-404.2.11*.

Suggested Text of Proposed Amendment

11B-404.2.11 Vision lights. Doors, gates, and side lights adjacent to doors or gates, containing one or more glazing panels that permit viewing through the panels shall have the bottom of at least one glazed panel located 43 inches (1092 mm) maximum above the finish floor.

Exception: *Exceptions:*

1. *Glazing panels* with the lowest part more than 66 inches (1676 mm) from the finish floor or ground shall not be required to comply with *Section 11B-404.2.11*.
2. *In detention and correctional facilities, vision lights used only by security personnel shall not be required to comply with Section 11B-404.2.11.*

Code Text if Adopted

11B-404.2.11 Vision lights. Doors, gates, and side lights adjacent to doors or gates, containing one or more glazing panels that permit viewing through the panels shall have the bottom of at least one glazed panel located 43 inches (1092 mm) maximum above the finish floor.

Exceptions:

1. *Glazing panels* with the lowest part more than 66 inches (1676 mm) from the finish floor or ground shall not be required to comply with *Section 11B-404.2.11*.
2. *In detention and correctional facilities, vision lights used only by security personnel shall not be required to comply with Section 11B-404.2.11.*

DSA CODE AMENDMENT DEVELOPMENT**Rationale**

Existing section 11B-404.2.11 requires the bottom of at least one glazed panel on a door, where provided, be located 43 inches maximum above the finish floor. This height allows use of the vision panel by individuals seated in wheelchairs. Within detention and correctional facilities, vision panels are used by security personnel to make visual security checks into areas; these panels are not provided to permit other types of viewing. The existing exception for glazing panels, with the lowest part at more than 66 inches, is not adequate as correctional officers of lower stature would not be able to perform their duties of viewing into areas.

DSA-AC is proposing to add an exception to allow vision lights designed to be used only by security personnel. This proposed exception would allow for vision panels to be located higher than what the current code provision permits. Vision panels are essential functional elements of the security personnel's work area. The ADA Standards require compliance with limited accessibility provisions in employee work areas and typically do not apply to work elements used solely by employees. This proposal addresses the design of vision panels used only by security personnel for work and complies with the 2010 ADA standards for Accessible Design.

CBSC-CAC Action: Approve as submitted.

DSA Response to CAC: Accepted.

Comments



DSA CODE AMENDMENT DEVELOPMENT

Tracking	
Date Received:	-
DSA Tracking Number:	ITEM 11B.14
Date Reviewed:	11/13/2018
Status:	Final Submittal

Applicable Code
Applicable Code Section(s): 11B-405.9.2
Topic: Ramp edge protection

Current Code Language

11B-405 Ramps

11B-405.9 Edge protection. Edge protection complying with...

11B-405.9.2 Curb or barrier. A curb, *2 inches (51 mm) high minimum*, or barrier shall be provided that prevents the passage of a 4 inch (102 mm) diameter sphere, where any portion of the sphere is within 4 inches (102 mm) of the finish floor or ground surface. *To prevent wheel entrapment, the curb or barrier shall provide a continuous and uninterrupted barrier along the length of the ramp.*

Suggested Text of Proposed Amendment

11B-405 Ramps

11B-405.9 Edge protection. Edge protection complying with...

11B-405.9.2 Curb or barrier. A curb, ~~2 inches (51 mm) high minimum~~, or barrier shall be provided that prevents the passage of a 4 inch (102 mm) diameter sphere, where any portion of the sphere is within 4 inches (102 mm) of the finish floor or ground surface. *To prevent wheel entrapment, the curb or barrier shall provide a continuous and uninterrupted barrier along the length of the ramp.*

Code Text if Adopted

11B-405 Ramps

11B-405.9 Edge protection. Edge protection complying with...

11B-405.9.2 Curb or barrier. A curb or barrier shall be provided that prevents the passage of a 4 inch (102 mm) diameter sphere, where any portion of the sphere is within 4 inches (102 mm) of the finish floor or ground surface. *To prevent wheel entrapment, the curb or barrier shall provide a continuous and uninterrupted barrier along the length of the ramp.*

Rationale

During the 2012 Rulemaking Cycle, DSA-AC carried forward existing requirements for ramp edge protection curbs to be 2 inches high minimum, and combined this language with language from the 2010 ADA Standards for Accessible Design (ADAS) 405.9.2 which addressed the same element. Subsequently, DSA has received comments that the 2 inches high language can lead to designs that don't comply with the 2010 ADAS which require a curb or barrier which prevents a 4 inches diameter sphere from passing within 4 inches of the ramp surface. While it is possible to combine a 2 inches high

DSA CODE AMENDMENT DEVELOPMENT

curb with other elements such as a rail to comply prevent the 4 inch diameter sphere from passing within 4 inches of the ramp surface, some may interpret the current language to allow a 2 inches high curb without other elements being provided in combination. This interpretation is inaccurate; a 4 inches high curb without other elements being provided in combination would be required to prevent a 4 inches diameter sphere from passing within 4 inches of the ramp surface. DSA-AC is proposing to amend the first sentence in this section to be consistent with 2010 ADAS 405.9.2 for greater clarity.

CBSC-CAC Action: Approve as submitted.

DSA Response to CAC: Accepted.

Comments

- 2010 ADA Standards:
405.9.2 Curb or Barrier. A curb or barrier shall be provided that prevents the passage of a 4 inch (100 mm) diameter sphere, where any portion of the sphere is within 4 inches (100 mm) of the finish floor or ground surface.
- From US Access Board's *Guide to the ADA Standards*:

Edge Protection [[§405.9](#)]

Edge protection along ramp runs and landings keep wheelchair casters and crutch tips on the surface and can be provided by curbs, barriers, or extended surfaces.

Edge Protection Alternatives

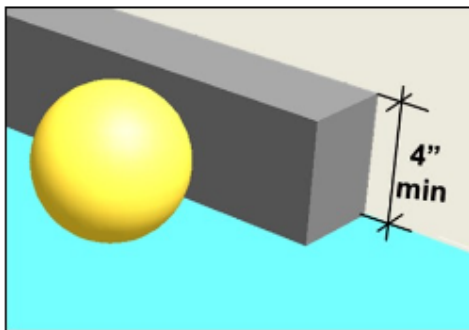

Curbs if used must be at least 4" high.

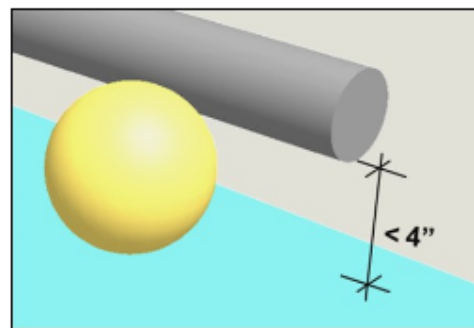

Rails or other barriers must prevent passage of a 4" diameter sphere.



DSA CODE AMENDMENT DEVELOPMENT

Tracking	
Date Received:	-
DSA Tracking Number:	ITEM 11B.15
Date Reviewed:	09/04/2018
Status:	Final Submittal

Applicable Code
Applicable Code Section(s): 11B-502.5
Topic: Vertical clearance at existing parking structures

Current Code Language

11B-502 Parking spaces

11B-502.5 Vertical clearance. Parking spaces, access aisles and vehicular routes serving them shall provide a vertical clearance of 98 inches (2489 mm) minimum.

Suggested Text of Proposed Amendment

11B-502 Parking spaces

11B-502.5 Vertical clearance. Parking spaces, access aisles and vehicular routes serving them shall provide a vertical clearance of 98 inches (2489 mm) minimum.

Exception: In existing multi-story parking facilities, car parking spaces, access aisles and vehicular routes serving them shall provide a vertical clearance of 80 inches (2032 mm) minimum. Existing vertical clearance in excess of 80 inches (2032 mm) and less than 98 inches (2489 mm) shall be maintained. This exception shall not apply to van parking spaces, access aisles, or vehicular routes serving them.

Code Text if Adopted

11B-502 Parking spaces

11B-502.5 Vertical clearance. Parking spaces, access aisles and vehicular routes serving them shall provide a vertical clearance of 98 inches (2489 mm) minimum.

Exception: In existing multi-story parking facilities, car parking spaces, access aisles and vehicular routes serving them shall provide a vertical clearance of 80 inches (2032 mm) minimum. Existing vertical clearance in excess of 80 inches (2032 mm) and less than 98 inches (2489 mm) shall be maintained. This exception shall not apply to van parking spaces, access aisles, or vehicular routes serving them.

Rationale

Existing section 11B-502.5 requires a vertical clearance of 98 inches for accessible parking spaces, access aisles and vehicular routes serving them. This section applies to van and car accessible parking

DSA CODE AMENDMENT DEVELOPMENT

in new and existing conditions. Vertical clearance in existing multi-story parking facilities is often inadequate to provide strict compliance with this requirement and requires the building official to determine the existing condition is technically infeasible to allow accessible parking with a vertical clearance lower than 98 inches.

DSA-AC is proposing to add an exception to allow a lower vertical clearance of 80 inches minimum for car accessible (but not van accessible) parking spaces, access aisles, and vehicle routes serving them in existing multi-story parking facilities. This proposal requires existing vertical clearances in excess of 80 inches and less than 98 inches to be maintained without reduction to provide the greatest vertical clearance possible in these existing facilities. 80 inches minimum vertical clearance at car accessible parking spaces, access aisles and vehicular routes serving them complies with the 2010 ADA Standards for Accessible Design.

CBSC-CAC Action: Approve as submitted.

DSA Response to CAC: Accepted.

Comments

- 2015 RM / CAC Meeting – DSA initially proposed an exception to allow 80” vertical clearance to standard (not van) accessible spaces, access aisles, and vehicular ways serving them in **existing** multi-story parking facilities; this item was withdrawn.
- 80 inches minimum vertical clearance at car accessible parking spaces, access aisles and vehicular routes serving them complies with the 2010 ADA Standards for Accessible Design.

DSA CODE AMENDMENT DEVELOPMENT

Tracking	
Date Received:	-
DSA Tracking Number:	ITEM 11B.16, RELATED ITEM 11B.16.01
Date Reviewed:	11/13/2018
Status:	Final Submittal

Applicable Code
Applicable Code Section(s): 11B-604.8.1.2
Topic: Accessible toilet compartment – 4" stile

Current Code Language

11B-604.8.1.2 Doors. Toilet compartment doors... Doors shall be located in the front partition or in the side wall or partition farthest from the water closet. Where located in the front partition, the door opening shall be 4 inches (102 mm) maximum from the side wall or partition farthest from the water closet. Where located in the side wall or partition, the door opening shall be 4 inches (102 mm) maximum from the front partition. ...

Related:

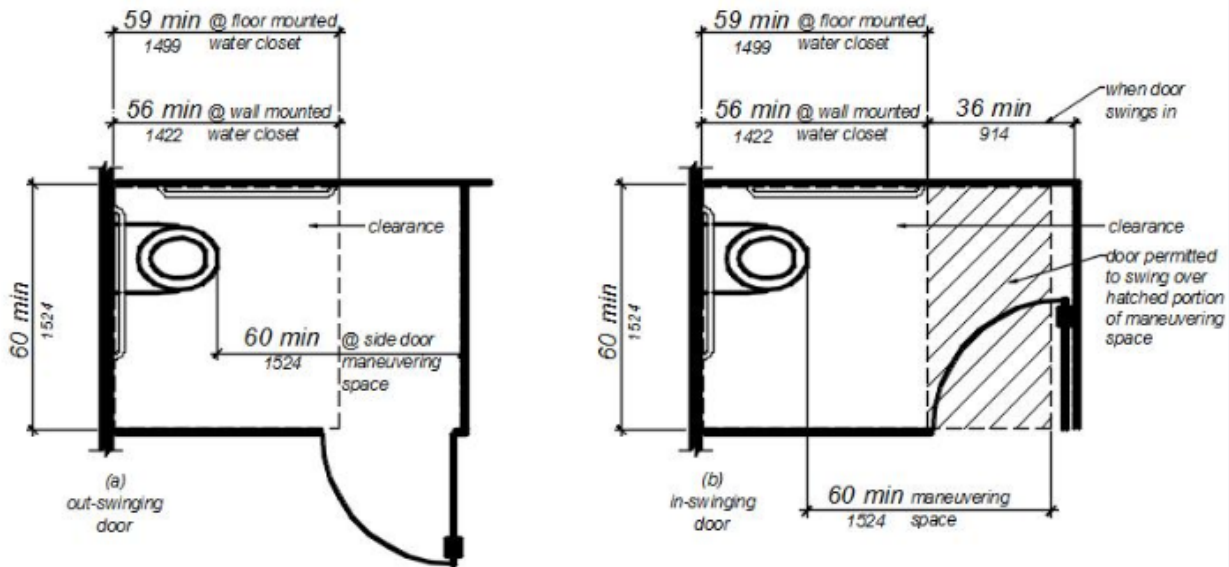

**FIGURE 11B-604.8.1.2
MANEUVERING SPACE WITH SIDE-OPENING DOOR**

DSA CODE AMENDMENT DEVELOPMENT

Suggested Text of Proposed Amendment

11B-604.8.1.2 Doors. Toilet compartment doors... Doors shall be located in the front partition or in the side wall or partition farthest from the water closet. Where located in the front partition, the door opening shall be 4 inches (102 mm) maximum from the side wall or partition farthest from the water closet. Where located in the side wall or partition, ~~the door opening shall be 4 inches (102 mm) maximum from the front partition~~ the door opening hinge side jamb for out-swinging doors shall be farthest from the water closet and the strike side jamb shall be 54 inches (1372 mm) minimum from the rear wall. ...

Related:

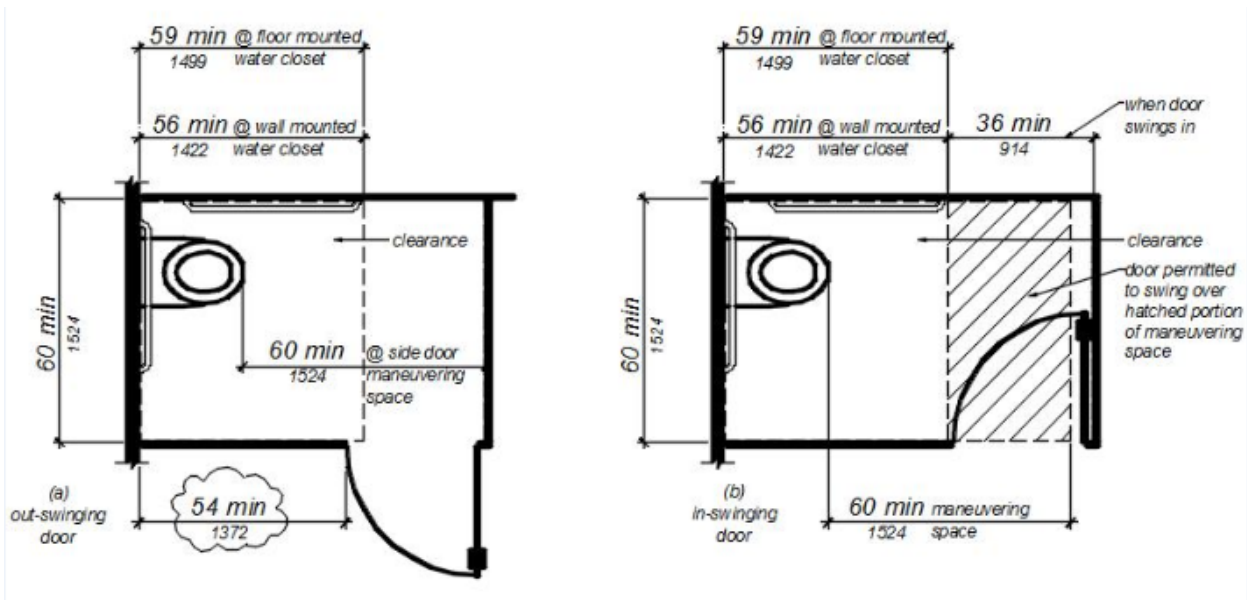

**FIGURE 11B-604.8.1.2
MANEUVERING SPACE WITH SIDE-OPENING DOOR**

Code Text if Adopted

11B-604.8.1.2 Doors. Toilet compartment doors... Doors shall be located in the front partition or in the side wall or partition farthest from the water closet. Where located in the front partition, the door opening shall be 4 inches (102 mm) maximum from the side wall or partition farthest from the water closet. Where located in the side wall or partition, *the door opening hinge side jamb for out-swinging doors shall be farthest from the water closet and the strike side jamb shall be 54 inches (1372 mm) minimum from the rear wall.* ...

DSA CODE AMENDMENT DEVELOPMENT

Related:

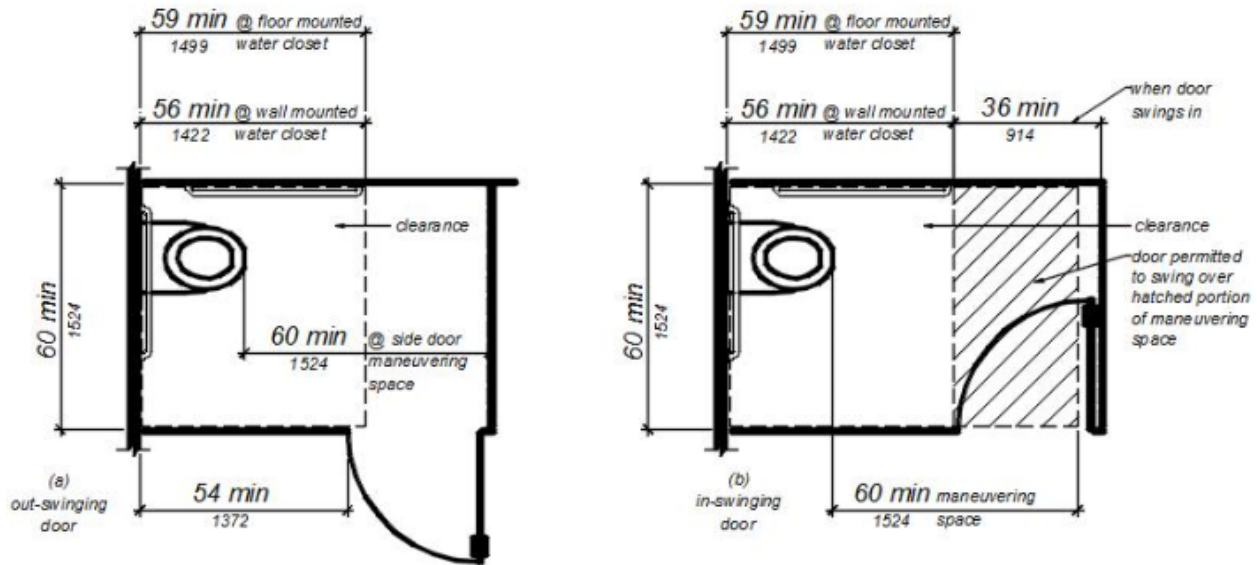

**FIGURE 11B-604.8.1.2
MANEUVERING SPACE WITH SIDE-OPENING DOOR**

Rationale

DSA-AC is proposing to amend Section 11B-604.8.1.2 and Figure 11B-604.8.1.2 to revise the required location for out-swinging toilet compartment doors in the side wall or partition of an accessible toilet compartment. The current provisions require the door to be 4 inches maximum from the front partition. This proposal allows the toilet compartment door to be located in a variety of locations in the side wall or partition while maintaining equal or greater accessibility than the current CBC Chapter 11B requirements and the 2010 ADA Standards for Accessible design.

CBSC-CAC Action: Approve as submitted.

DSA Response to CAC: Accepted.

Comments

- Required door location provides direct access to the wide side of the water closet.
- Existing CBC language is from the 2010 ADA Standards which, in turn, was illustrated in the 1991/1994 ADA Standards. The federal illustrations showed the 4" dimension only in the minimum sized federal accessible toilet compartment.
- California accessible toilet compartment depth requirements significantly exceed the federal requirements.

DSA CODE AMENDMENT DEVELOPMENT



DSA CODE AMENDMENT DEVELOPMENT

Tracking	
Date Received:	-
DSA Tracking Number:	ITEM 11B.17, RELATED ITEM 11B.17.01, RELATED ITEM 11B.17.02
Date Reviewed:	11/13/2018
Status:	Final Submittal

Applicable Code
Applicable Code Section(s): 11B-608.2.1
Topic: Technical section for transfer type shower compartment

Current Code Language

Chapter 11B, Section 11B-213.3.6

11B-213.3.6 Bathing facilities. Where bathtubs or showers are provided, at least one bathtub complying with *Section 11B-607* or at least one shower complying with *Section 11B-608* shall be provided. *Where two or more accessible showers are provided within the same functional area, at least one shower shall be opposite hand from the other or others (that is, one left-hand controls versus right-hand controls).*

Chapter 11B, Section 11B-608.2

11B-608.2 Size and clearances for shower compartments. Shower compartments shall have sizes and clearances complying with *Section 11B-608.2*.

11B-608.2.1 Reserved.

Suggested Text of Proposed Amendment

Chapter 11B, Section 11B-213.3.6

11B-213.3.6 Bathing facilities. Where bathtubs or showers are provided, at least one bathtub complying with *Section 11B-607* or at least one shower complying with *Section 11B-608* shall be provided. *Where two or more accessible showers are provided within the same functional area, at least one shower shall be opposite hand from the other or others (that is, one left-hand controls versus right-hand controls).* Transfer type shower compartments shall be permitted in transient lodging quest rooms, multi-bedroom housing units in undergraduate student housing and residential dwelling units; and shall not be permitted at other locations to meet the requirements of Section 11B-213.3.6.

Chapter 11B, Section 11B-608.2

11B-608.2 Size and clearances for shower compartments. Shower compartments shall have sizes and clearances complying with *Section 11B-608.2*.

11B-608.2.1 Reserved.

11B-608.2.1 Transfer Type Shower Compartments. Transfer type shower compartments shall be 36 inches (914 mm) by 36 inches (914 mm) clear inside dimensions measured at the center points of

DSA CODE AMENDMENT DEVELOPMENT

opposing sides and shall have a 36 inch (914 mm) wide minimum entry on the face of the shower compartment. Clearance of 36 inches (914 mm) wide minimum by 48 inches (1219 mm) long minimum measured from the control wall shall be provided. Transfer type shower compartments shall be permitted in transient lodging quest rooms, multi-bedroom housing units in undergraduate student housing and residential dwelling units; and shall not be permitted at other locations to meet the requirements of Section 11B-213.3.6.

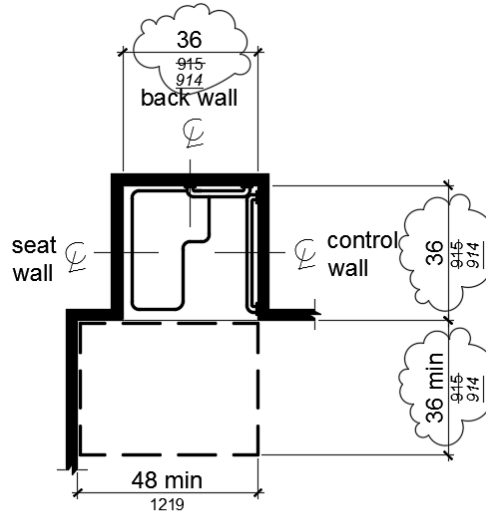

Note: inside finished dimensions measured at the center points of opposing sides

FIGURE 11B-608.2.1 TRANSFER TYPE SHOWER COMPARTMENT SIZE AND CLEARANCE

Code Text if Adopted

Chapter 11B, Section 11B-213.3.6

11B-213.3.6 Bathing facilities. Where bathtubs or showers are provided, at least one bathtub complying with *Section 11B-607* or at least one shower complying with *Section 11B-608* shall be provided. *Where two or more accessible showers are provided within the same functional area, at least one shower shall be opposite hand from the other or others (that is, one left-hand controls versus right-hand controls). Transfer type shower compartments shall be permitted in transient lodging guest rooms, multi-bedroom housing units in undergraduate student housing and residential dwelling units; and shall not be permitted at other locations to meet the requirements of Section 11B-213.3.6.*

Chapter 11B, Section 11B-608.2

11B-608.2 Size and clearances for shower compartments. Shower compartments shall have sizes and clearances complying with *Section 11B-608.2*.

11B-608.2.1 Transfer Type Shower Compartments. Transfer type shower compartments shall be 36 inches (914 mm) by 36 inches (914 mm) clear inside dimensions measured at the center points of opposing sides and shall have a 36 inch (914 mm) wide minimum entry on the face of the shower compartment. Clearance of 36 inches (914 mm) wide minimum by 48 inches (1219 mm) long minimum measured from the control wall shall be provided. *Transfer type shower compartments shall be permitted in transient lodging guest rooms, multi-bedroom housing units in undergraduate student*

DSA CODE AMENDMENT DEVELOPMENT

housing and residential dwelling units; and shall not be permitted at other locations to meet the requirements of Section 11B-213.3.6.

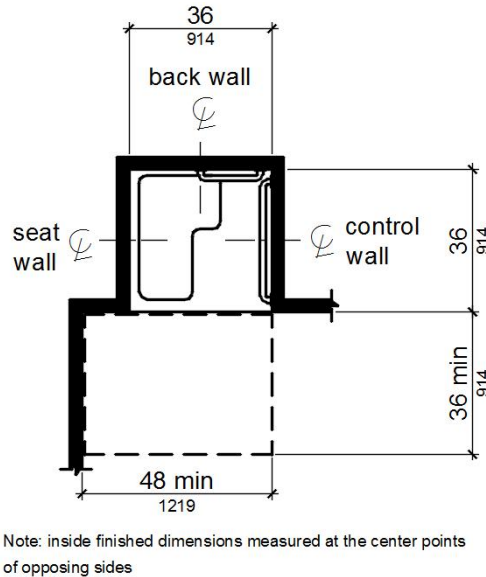

FIGURE 11B-608.2.1 TRANSFER TYPE SHOWER COMPARTMENT SIZE AND CLEARANCE

Rationale

DSA is proposing this code change in response to users of mobility devices who prefer this type of shower stall. By not allowing the use of a transfer shower, in facilities regulated by Chapter 11B, persons with disabilities are denied an option that may better meet their needs. The transfer type shower stall allows for the mobility device to be placed outside of the wet area while using the shower compartment and provides for controls that are within reach range when seated. This amendment, if approved, will align the provisions for a transfer type shower compartment in Chapter 11B with the 2010 ADAS.

The provisions limiting the locations where transfer type shower compartments are permitted is in response to the comments of the Code Advisory Committee members for this item. A committee member asked if transfer type showers would be allowed in medical facility patient rooms. As proposed a roll-n shower is required where showers are provided in medical facility patient rooms.

CBSC-CAC Action: Further study.

DSA Response to CAC: Accepted. DSA has studied this item and has included scoping to clarify locations where transfer type shower compartments are allowed and where roll-in type showers are required.

Comments

DSA CODE AMENDMENT DEVELOPMENT

DSA CODE AMENDMENT DEVELOPMENT

Tracking	
Date Received:	-
DSA Tracking Number:	ITEM 11B.18, RELATED ITEM 11B.18.01
Date Reviewed:	11/13/2018
Status:	Final Submittal

Applicable Code
Applicable Code Section(s): 11B-608.3.1
Topic: Technical section for transfer type shower compartment grab bars

Current Code Language

11B-608.3 Grab bars. Grab bars

11B-608.3.1 Reserved.

Suggested Text of Proposed Amendment

11B-608.3 Grab bars. Grab bars

~~11B-608.3.1 Reserved.~~

11B-608.3.1 Transfer Type Shower Compartments. In transfer type compartments, grab bars shall be provided across the control wall and back wall to a point 18 inches (457 mm) from the

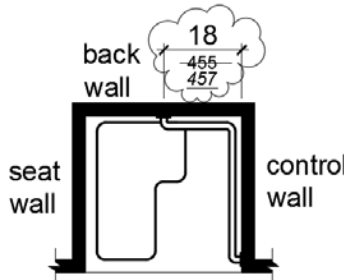

control wall.

FIGURE 11B-608.3.1 GRAB BARS FOR TRANSFER TYPE SHOWERS

Code Text if Adopted

11B-608.3 Grab bars. Grab bars

11B-608.3.1 Transfer Type Shower Compartments. In transfer type compartments, grab bars shall be provided across the control wall and back wall to a point 18 inches (457 mm) from the control wall.

DSA CODE AMENDMENT DEVELOPMENT

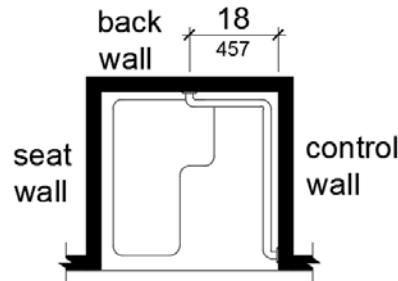

FIGURE 11B-608.3.1 GRAB BARS FOR TRANSFER TYPE SHOWERS

Rationale

DSA is proposing this code change as a related amendment to Section 11B-608.2.1 to address the requirements for grab bars in transfer type showers.

CBSC-CAC Action: Further study.

DSA Response to CAC: Accepted. DSA has studied this code change proposal and has determined that an elevation is not necessary to illustrate the requirements for this code section. The comments made in reference to related sections have been studied and addressed.

Comments



DSA CODE AMENDMENT DEVELOPMENT

Tracking	
Date Received:	-
DSA Tracking Number:	ITEM 11B.19
Date Reviewed:	11/13/2018
Status:	Final Submittal

Applicable Code
Applicable Code Section(s): 11B-608.4
Topic: Technical section for transfer type shower seats

Current Code Language

11B-608.4 Seats. A folding seat shall be provided in roll-in type showers. Seats shall comply with *Section 11B-610*.

Exception: In residential dwelling units, seats shall not be required in shower compartments provided that reinforcement has been installed in walls so as to permit the installation of seats complying with *Section 11B-608.4*.

Suggested Text of Proposed Amendment

11B-608.4 Seats. A folding seat shall be provided in roll-in type showers and transfer type shower compartments. Seats shall comply with *Section 11B-610*.

Exception: In residential dwelling units, seats shall not be required in shower compartments provided that reinforcement has been installed in walls so as to permit the installation of seats complying with *Section 11B-608.4*.

Code Text if Adopted

11B-608.4 Seats. A folding seat shall be provided in roll-in type showers and transfer type shower compartments. Seats shall comply with *Section 11B-610*.

Exception: In residential dwelling units, seats shall not be required in shower compartments provided that reinforcement has been installed in walls so as to permit the installation of seats complying with *Section 11B-608.4*.

Rationale

DSA is proposing this code change as a related amendment to Section 11B-608.2.1 to address the requirements for seats in transfer type showers.

CBSC-CAC Action: Further study.

DSA Response to CAC: Accepted. No comments were made specific to this code change proposal. The comments made in reference to related sections have been studied and addressed.

Comments

DSA CODE AMENDMENT DEVELOPMENT

Tracking	
Date Received:	-
DSA Tracking Number:	ITEM 11B.20, RELATED ITEM 11B.20.01
Date Reviewed:	11/13/2018
Status:	Final Submittal

Applicable Code
Applicable Code Section(s): 11B-608.5, 11B-608.5.1
Topic: Shower controls

Current Code Language

11B-608.5 Controls. Controls, faucets, and shower spray units shall comply with Section 11B-309.4. Controls and faucets shall be of a single-lever design.

11B-608.5.1 Reserved.

Suggested Text of Proposed Amendment

11B-608.5 Controls. Controls, faucets, and shower spray units shall comply with Section 11B-309.4. Controls and faucets shall ~~be of a single-lever design.~~ allow the user to close and open the water supply.

~~**11B-608.5.1 Reserved.**~~

11B-608.5.1 Transfer Type Shower Compartments. In transfer type shower compartments, the controls, faucets, and shower spray unit shall be installed on the side wall opposite the seat 38 inches (965 mm) minimum and 48 inches (1219 mm) maximum above the shower floor and shall be located on the control wall 15 inches (380 mm) maximum from the centerline of the seat toward the shower opening.

Related:

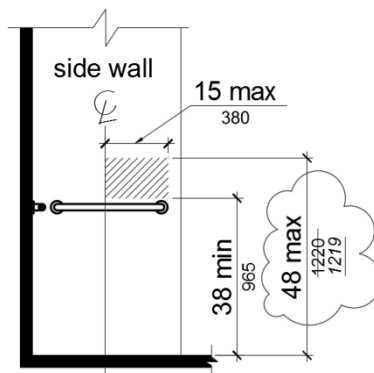

DSA CODE AMENDMENT DEVELOPMENT

**FIGURE 11B-608.5.1 TRANSFER TYPE
SHOWER COMPARTMENT CONTROL LOCATION**

Code Text if Adopted

11B-608.5 Controls. Controls, faucets, and shower spray units shall comply with Section 11B-309.4. Controls and faucets shall allow the user to close and open the water supply.

11B-608.5.1 Transfer Type Shower Compartments. In transfer type shower compartments, the controls, faucets, and shower spray unit shall be installed on the side wall opposite the seat 38 inches (965 mm) minimum and 48 inches (1219 mm) maximum above the shower floor and shall be located on the control wall 15 inches (380 mm) maximum from the centerline of the seat toward the shower opening.

Related:

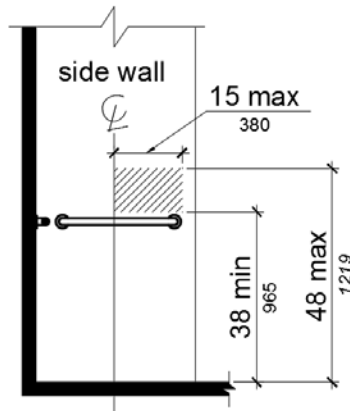

**FIGURE 11B-608.5.1 TRANSFER TYPE
SHOWER COMPARTMENT CONTROL LOCATION**

Rationale

DSA is proposing two amendments to this section.

- The first amendment addresses controls that are a single lever design. Other types of controls such as a push button could meet the requirements for operable parts that are referenced to Section 11B-309.4. Therefore DSA is proposing to repeal the requirement that controls shall be a single lever design.

The second amendment DSA is proposing is related the code change proposal in Section 11B-608.2.1 to provide the requirements for controls in transfer type showers.

CBSC-CAC Action: Approve as Submitted. 11B-608.5

DSA Response to CAC: Accepted.

CBSC-CAC Action: Further Study. 11B-608.5.1

DSA Response to CAC: Accepted. DSA has determined, after further study, to retain the code change proposal with the location of the shower controls as written. The location of the shower controls as

DSA CODE AMENDMENT DEVELOPMENT

proposed is consistent with the; 2010 ADA Standards for Accessible Design, Uniform Federal Accessibility Standards, Fair Housing Act Design Manual and the California Plumbing Code.

Comments

DSA CODE AMENDMENT DEVELOPMENT



DSA CODE AMENDMENT DEVELOPMENT

Tracking	
Date Received:	-
DSA Tracking Number:	ITEM 11B.21
Date Reviewed:	11/13/2018
Status:	Final Submittal

Applicable Code
Applicable Code Section(s): 11B-608.7
Topic: Technical section for transfer type shower thresholds

Current Code Language

11B-608.7 Thresholds. Thresholds in roll-in type shower compartments shall be ½ inch (12.7 mm) high maximum in accordance with *Section 11B-303*.

Exception: Reserved.

Suggested Text of Proposed Amendment

11B-608.7 Thresholds. Thresholds in roll-in type shower compartments shall be ½ inch (12.7 mm) high maximum in accordance with *Section 11B-303*. In transfer type shower compartments, thresholds ½ inch (12.7 mm) high maximum shall be beveled, rounded, or vertical.

Exception: Reserved.

Exception: A threshold 2 inches (51 mm) high maximum shall be permitted in transfer type shower compartments in existing facilities where provision of a ½ inch (12.7 mm) high threshold would disturb the structural reinforcement of the floor slab.

Code Text if Adopted

11B-608.7 Thresholds. Thresholds in roll-in type shower compartments shall be ½ inch (12.7 mm) high maximum in accordance with *Section 11B-303*. In transfer type shower compartments, thresholds ½ inch (12.7 mm) high maximum shall be beveled, rounded, or vertical.

Exception: A threshold 2 inches (51 mm) high maximum shall be permitted in transfer type shower compartments in existing facilities where provision of a ½ inch (12.7 mm) high threshold would disturb the structural reinforcement of the floor slab.

Rationale

DSA is proposing this code change as a related amendment to Section 11B-608.2.1 to address the requirements for thresholds in transfer type showers.

CBSC-CAC Action: Further study.

DSA Response to CAC: Accepted. No comments were made specific to this code change proposal. The comments made in reference to related sections have been studied and addressed.

DSA CODE AMENDMENT DEVELOPMENT

Comments

DSA CODE AMENDMENT DEVELOPMENT

Tracking	
Date Received:	-
DSA Tracking Number:	ITEM 11B.22
Date Reviewed:	11/13/2018
Status:	Final Submittal

Applicable Code
Applicable Code Section(s): 11B-610.03
Topic: Technical section for transfer type shower seats

Current Code Language

11B-610.3 Shower compartment seats. A seat in a standard roll-in shower compartment shall be a folding type, shall be installed on the side wall adjacent to the controls, and shall extend from the back wall to a point within 3 inches (76 mm) of the compartment entry. A seat in an alternate roll-in type shower compartment shall be a folding type, shall be installed on the front wall opposite the back wall, and shall extend from the adjacent side wall to a point within 3 inches (76 mm) of the compartment entry. The top of the seat shall be 17 inches (432 mm) minimum and 19 inches (483 mm) maximum above the bathroom finish floor. *When folded, the seat shall extend 6 inches (152 mm) maximum from the mounting wall.* Seats shall comply with Section 11B-610.3.1 or 11B-610.3.2.

Suggested Text of Proposed Amendment

11B-610.3 Shower compartment seats. A seat in a standard roll-in shower compartment shall be a folding type, shall be installed on the side wall adjacent to the controls, and shall extend from the back wall to a point within 3 inches (76 mm) of the compartment entry. A seat in an alternate roll-in type shower compartment shall be a folding type, shall be installed on the front wall opposite the back wall, and shall extend from the adjacent side wall to a point within 3 inches (76 mm) of the compartment entry. In transfer-type showers, the seat shall extend from the back wall to a point within 3 inches (76 mm) of the compartment entry. The top of the seat shall be 17 inches (432 mm) minimum and 19 inches (483 mm) maximum above the bathroom finish floor. *When folded, the seat shall extend 6 inches (152 mm) maximum from the mounting wall.* Seats shall comply with Section 11B-610.3.1 or 11B-610.3.2.

Code Text if Adopted

11B-610.3 Shower compartment seats. A seat in a standard roll-in shower compartment shall be a folding type, shall be installed on the side wall adjacent to the controls, and shall extend from the back wall to a point within 3 inches (76 mm) of the compartment entry. A seat in an alternate roll-in type shower compartment shall be a folding type, shall be installed on the front wall opposite the back wall, and shall extend from the adjacent side wall to a point within 3 inches (76 mm) of the compartment entry. In transfer-type showers, the seat shall extend from the back wall to a point within 3 inches (76 mm) of the compartment entry. The top of the seat shall be 17 inches (432 mm) minimum and 19 inches (483 mm) maximum above the bathroom finish floor. *When folded, the seat shall extend 6 inches (152 mm) maximum from the mounting wall.* Seats shall comply with Section 11B-610.3.1 or 11B-610.3.2.

DSA CODE AMENDMENT DEVELOPMENT

Rationale

DSA is proposing this code change as a related amendment to Section 11B-608.2.1 to address the requirements for seats in transfer type showers.

CBSC-CAC Action: Further study.

DSA Response to CAC: Accepted. No comments were made specific to this code change proposal. The comments made in reference to related sections have been studied and addressed.

Comments

DSA CODE AMENDMENT DEVELOPMENT

Tracking	
Date Received:	-
DSA Tracking Number:	ITEM 11B.23
Date Reviewed:	11/13/2018
Status:	Final Submittal

Applicable Code
Applicable Code Section(s): 11B-703.7.2.7
Topic: Pedestrian traffic control buttons

Current Code Language

11B-703.7.2.7 Pedestrian traffic-control buttons.

Pole-supported pedestrian traffic-control buttons shall be identified with color coding consisting of a textured horizontal yellow band 2 inches (51 mm) in width encircling the pole, and a 1-inch-wide (25 mm) dark border band above and below this yellow band. Color coding shall be placed immediately above the control button. Control buttons shall be located no higher than 48 inches (1219 mm) above the ground surface adjacent to the pole.

Suggested Text of Proposed Amendment

~~11B-703.7.2.7 Pedestrian traffic-control buttons.~~

~~*Pole-supported pedestrian traffic-control buttons shall be identified with color coding consisting of a textured horizontal yellow band 2 inches (51 mm) in width encircling the pole, and a 1-inch-wide (25 mm) dark border band above and below this yellow band. Color coding shall be placed immediately above the control button. Control buttons shall be located no higher than 48 inches (1219 mm) above the ground surface adjacent to the pole.*~~

Code Text if Adopted

N/A

Rationale

DSA has received legal advice that regulation of pedestrian traffic-control buttons is not within its authority to write building code provisions for accessibility. Rather, items such as pedestrian traffic control buttons are traffic control devices and properly regulated by the California Manual on Uniform Traffic Control Devices (CA MUTCD) which is maintained by the California Department of Transportation (CalTrans). Accordingly, DSA-AC is proposing to strike Section 11B-703.7.2.7.

DSA-AC notes that the CA MUTCD Chapter 4E provides standards and guidance for pedestrian control features, including Section 4E.12 (Accessible Pedestrian Signals and Detectors – Tactile Arrows and Locator Tones). This section requires pushbuttons to clearly indicate by means of tactile arrows which crosswalk signal is actuated by each pushbutton, tactile arrow location on the pushbutton, high visual contrast (light on dark or dark on light), and alignment parallel to the direction of travel on the associated crosswalk.

DSA CODE AMENDMENT DEVELOPMENT

CBSC-CAC Action: Approve as submitted.

DSA Response to CAC: Accepted.

Comments

DSA CODE AMENDMENT DEVELOPMENT

Tracking	
Date Received:	-
DSA Tracking Number:	ITEM 11B.24
Date Reviewed:	11/13/2018
Status:	Final Submittal

Applicable Code
Applicable Code Section(s): 11B-812.8.7
Topic: Parking signs at accessible routes

Current Code Language

11B-812.8.7 Location. Required identification signs shall be visible from the EVCS it serves. Signs shall be permanently posted either immediately adjacent to the vehicle space or within the projected vehicle space width at the head end of the vehicle space. Signs identifying van accessible vehicle spaces shall contain the designation “van accessible.” Signs shall be 60 inches (1525 mm) minimum above the finish floor or ground surface measured to the bottom of the sign. Signs located within an accessible route shall be 80 inches (2032 mm) minimum above the finish floor or ground surface measured to the bottom of the sign. Signs may also be permanently posted on a wall at the interior end of the vehicle space.

Suggested Text of Proposed Amendment

11B-812.8.7 Location. Required identification signs shall be visible from the EVCS it serves. Signs shall be permanently posted either immediately adjacent to the vehicle space or within the projected vehicle space width at the head end of the vehicle space. Signs identifying van accessible vehicle spaces shall contain the designation “van accessible.” Signs shall be 60 inches (1525 mm) minimum above the finish floor or ground surface measured to the bottom of the sign. Signs located within ~~an accessible route~~ a circulation path shall be 80 inches (2032 mm) minimum above the finish floor or ground surface measured to the bottom of the sign. Signs may also be permanently posted on a wall at the interior end of the vehicle space.

Code Text if Adopted

11B-812.8.7 Location. Required identification signs shall be visible from the EVCS it serves. Signs shall be permanently posted either immediately adjacent to the vehicle space or within the projected vehicle space width at the head end of the vehicle space. Signs identifying van accessible vehicle spaces shall contain the designation “van accessible.” Signs shall be 60 inches (1525 mm) minimum above the finish floor or ground surface measured to the bottom of the sign. Signs located within a circulation path shall be 80 inches (2032 mm) minimum above the finish floor or ground surface measured to the bottom of the sign. Signs may also be permanently posted on a wall at the interior end of the vehicle space.

Rationale

Current requirements in Section 11B-812.8.7 for identification signs at electric vehicle charging stations include language to provide for a minimum vertical clearance of 80 inches for signs located within an accessible route. This requirement is inconsistent with Section 11B-307.3 (Protruding objects, post-

DSA CODE AMENDMENT DEVELOPMENT

mounted objects) which provides protection when signs are located in circulation paths. DSA-AC is proposing to amend Section 11B-812.8.7 to provide greater protection for people with people with visual disabilities consistent with the existing requirements in Section 11B-307.3.

CBSC-CAC Action: Approve as submitted.

DSA Response to CAC: Accepted.

Comments

- DSA received public comment pointing out that signs within circulation paths, rather than just accessible routes, would provide appropriate protection at electric vehicle spaces.
- Similar provision for parking spaces indicates circulation paths.